

PHILIPS

Data handbook



Electronic
components
and materials

Electron tubes

Part 11 October 1982

Microwave semiconductors

and components

CONTENTS

GENERAL SECTION

A

GUNN, IMPATT AND NOISE DIODES

B

MIXER AND DETECTOR DIODES

C

BACKWARD DIODES

D

MULTIPLIER VARACTOR DIODES

E

TUNING VARACTOR DIODES

F

LIMITER VARACTOR DIODES

G

SILICON BIPOLAR TRANSISTORS

H

GALLIUM ARSENIDE FET TRANSISTORS

J

OSCILLATORS

K

MIXER AND DETECTOR MODULES

L

DOPPLER MODULES AND VEHICLE DETECTORS

M

CIRCULATORS AND ISOLATORS

N

MISCELLANEOUS

P

INDEX



DATA HANDBOOK SYSTEM

Our Data Handbook System is a comprehensive source of information on electronic components, sub-assemblies and materials; it is made up of four series of handbooks each comprising several parts.

ELECTRON TUBES	BLUE
SEMICONDUCTORS	RED
INTEGRATED CIRCUITS	PURPLE
COMPONENTS AND MATERIALS	GREEN

The several parts contain all pertinent data available at the time of publication, and each is revised and reissued periodically.

Where ratings or specifications differ from those published in the preceding edition they are pointed out by arrows. Where application information is given it is advisory and does not form part of the product specification.

If you need confirmation that the published data about any of our products are the latest available, please contact our representative. He is at your service and will be glad to answer your inquiries.

This information is furnished for guidance, and with no guarantee as to its accuracy or completeness; its publication conveys no licence under any patent or other right, nor does the publisher assume liability for any consequence of its use; specifications and availability of goods mentioned in it are subject to change without notice; it is not to be reproduced in any way, in whole or in part without the written consent of the publisher.

ELECTRON TUBES (BLUE SERIES)

The blue series of data handbooks is comprised of the following parts:

- T1 Tubes for r.f. heating**
- T2 Transmitting tubes for communications**
- T3 Klystrons, travelling-wave tubes, microwave diodes**
- ET3 Special Quality tubes, miscellaneous devices (will not be reprinted)**
- T4 Magnetrons**
- T5 Cathode-ray tubes**
Instrument tubes, monitor and display tubes, C.R. tubes for special applications
- T6 Geiger-Müller tubes**
- T7 Gas-filled tubes**
Segment indicator tubes, indicator tubes, dry reed contact units, thyratrons, industrial rectifying tubes, ignitrons, high-voltage rectifying tubes, associated accessories
- T8 Picture tubes and components**
Colour TV picture tubes, black and white TV picture tubes, colour monitor tubes for data graphic display, monochrome monitor tubes for data graphic display, components for colour television, components for black and white television and monochrome data graphic display
- T9 Photo and electron multipliers**
Photomultiplier tubes, phototubes, single channel electron multipliers, channel electron multiplier plates
- T10 Camera tubes and accessories, image intensifiers**
- T11 Microwave components and assemblies**

SEMICONDUCTORS (RED SERIES)

The red series of data handbooks is comprised of the following parts:

- S1 Diodes**
Small-signal germanium diodes, small-signal silicon diodes, voltage regulator diodes (< 1,5 W), voltage reference diodes, tuner diodes, rectifier diodes
- S2 Power diodes, thyristors, triacs**
Rectifier diodes, voltage regulator diodes (> 1,5 W), rectifier stacks, thyristors, triacs
- S3 Small-signal transistors**
- S4 Low-frequency power transistors and hybrid IC modules**
- S5 Field-effect transistors**
- S6 R.F. power transistors and modules**
- S7 Microminiature semiconductors for hybrid circuits**
- S8 Devices for optoelectronics**
Photosensitive diodes and transistors, light-emitting diodes, displays, photocouplers, infrared sensitive devices, photoconductive devices.
- S9** Taken into handbook T11 of the blue series
- S10 Wideband transistors and wideband hybrid IC modules**

INTEGRATED CIRCUITS (PURPLE SERIES)

The purple series of data handbooks is comprised of the following parts:

- IC1** Bipolar ICs for radio and audio equipment
- IC2** Bipolar ICs for video equipment
- IC3** ICs for digital systems in radio, audio and video equipment
- IC4** Digital integrated circuits
LOCMOS HE4000B family
- IC5** Digital integrated circuits – ECL
ECL10 000 (GX family), ECL100 000 (HX family), dedicated designs
- IC6** Professional analogue integrated circuits
- IC7** Signetics bipolar memories
- IC8** Signetics analogue circuits
- IC9** Signetics TTL logic

COMPONENTS AND MATERIALS (GREEN SERIES)

The green series of data handbooks is comprised of the following parts:

- C1 Assemblies for industrial use**
PLC modules, PC20 modules, HNIL FZ/30 series, NORbits 60-, 61-, 90-series, input devices, hybrid ICs, peripheral devices
- C2 FM tuners, television tuners, video modulators, surface acoustic wave filters**
- C3 Loudspeakers**
- C4 Ferroxcube potcores, square cores and cross cores**
- C5 Ferroxcube for power, audio/video and accelerators**
- C6 Electric motors and accessories**
Permanent magnet synchronous motors, stepping motors, direct current motors
- C7 Variable capacitors***
- C8 Variable mains transformers**
- C9 Piezoelectric quartz devices**
Quartz crystal units, temperature compensated crystal oscillators, compact integrated oscillators, quartz crystal cuts for temperature measurements
- C10 Connectors**
- C11 Non-linear resistors**
Voltage dependent resistors (VDR), light dependent resistors (LDR), negative temperature coefficient thermistors (NTC), positive temperature coefficient thermistors (PTC)
- C12 Variable resistors and test switches**
- C13 Fixed resistors**
- C14 Electrolytic and solid capacitors**
- C15 Film capacitors, ceramic capacitors***
- C16 Piezoelectric ceramics, permanent magnet materials**

* C7 is in preparation. Retain C15 05-80 for information on variable capacitors until C7 becomes available.

GENERAL SECTION A





MICROWAVE SEMICONDUCTORS

GENERAL EXPLANATORY NOTES

TYPE NOMENCLATURE

Microwave semiconductor devices are registered with Pro-Electron.

The type nomenclature of a discrete device or, in certain cases, of a range of devices, consists of three letters followed by a serial number. The serial number normally consists of two figures, but a suffix letter is added where variants or a series occur.

The first letter indicates the semiconductor material used:

- A — germanium
- B — silicon
- C — compound materials, such as gallium arsenide

The second letter indicates the general function of the device:

- A — detection diode, mixer diode
- E — backward diode
- F — r.f. transistor
- L — power r.f. transistor
- X — multiplier diode such as varactor or step recovery diode

The third letter forms part of the serial number.

A suffix letter R after the complete type number denotes the reverse polarity version of a diode (body cathode) where applicable. A normal polarity version (body anode) has no suffix letter.

Subscripts for quantity symbols

- A, a anode terminal
- BR breakdown
- F, f forward
- I, i input
- J, j junction
- K, k cathode
- O, o open-circuit, output
- R, r resistive, reverse, repetitive
- S, s series, source
- Z, z impedance

ELECTRICAL PARAMETERS

	Device	Associated circuit
Resistance	r	R
Reactance	x	X
Impedance	z	Z
Admittance	y	Y
Conductance	g	G
Susceptance	b	B
Mutual inductance	m	M
Inductance	l	L
Capacitance	c	C
Frequency limits	f max. f min.	
Bandwidth	Δf	B
Noise factor		N

Symbols for microwave semiconductor devices

η	efficiency
B	bandwidth
C_d	diode capacitance
C_j	junction capacitance
C_{min}	diode capacitance at breakdown voltage
C_o	diode capacitance at zero bias
C_p	parasitic (parallel) capacitance
C_s	stray capacitance
C_{tot}	total capacitance
f	operating frequency
f_{co}	varactor diode cut-off frequency
I	current
I_{dc}	bias current
i.f.	intermediate frequency
I_F	d.c. forward current
I_{FM}	peak forward current
I_R	continuous (d.c.) reverse leakage current
L_c	conversion loss
L_s	series inductance
M	figure of merit
N_f	flicker noise
N_{if}	noise figure at intermediate frequency



N_o	overall noise figure
N_r	noise temperature ratio
P_{in}	input r.f. power
P_{out}	output r.f. power
P_{tot}	total power dissipated within the device
R_L	r.f. load resistance
R_s	spreading resistance
R_{th}	thermal resistance
S_i	current sensitivity
S_{ts}	tangential sensitivity
T_{amb}	ambient temperature
T_{case}	case temperature
T_{hs}	heatsink temperature at device interface with device
T_j	junction temperature
T_{stg}	storage temperature
t_p	pulse duration
t_s	storage time
t_{tr}	transition time
V	voltage
V_{BR}	breakdown voltage
$V_{(BR)R}$	reverse breakdown voltage
V_F	d.c. forward voltage
V_R	d.c. reverse voltage
v.s.w.r.	voltage standing wave ratio
Z_{if}	intermediate frequency impedance
Z_{rf}	radio frequency impedance
Z_v	video impedance
$1/f$	flicker noise

RATING SYSTEMS

The rating systems described are those recommended by the International Electrotechnical Commission (IEC) in its Publication 134.

DEFINITIONS OF TERMS USED

Electronic device. An electronic tube or valve, transistor or other semiconductor device.

Note

This definition excludes inductors, capacitors, resistors and similar components.

Characteristic. A characteristic is an inherent and measurable property of a device. Such a property may be electrical, mechanical, thermal, hydraulic, electro-magnetic, or nuclear, and can be expressed as a value for stated or recognized conditions. A characteristic may also be a set of related values, usually shown in graphical form.

Bogey electronic device. An electronic device whose characteristics have the published nominal values for the type. A bogey electronic device for any particular application can be obtained by considering only those characteristics which are directly related to the application.

Rating. A value which establishes either a limiting capability or a limiting condition for an electronic device. It is determined for specified values of environment and operation, and may be stated in any suitable terms.

Note

Limiting conditions may be either maxima or minima.

Rating system. The set of principles upon which ratings are established and which determine their interpretation.

Note

The rating system indicates the division of responsibility between the device manufacturer and the circuit designer, with the object of ensuring that the working conditions do not exceed the ratings.

ABSOLUTE MAXIMUM RATING SYSTEM

Absolute maximum ratings are limiting values of operating and environmental conditions applicable to any electronic device of a specified type as defined by its published data, which should not be exceeded under the worst probable conditions.

These values are chosen by the device manufacturer to provide acceptable serviceability of the device, taking no responsibility for equipment variations, environmental variations, and the effects of changes in operating conditions due to variations in the characteristics of the device under consideration and of all other electronic devices in the equipment.

The equipment manufacturer should design so that, initially and throughout life, no absolute maximum value for the intended service is exceeded with any device under the worst probable operating conditions with respect to supply voltage variation, equipment component variation, equipment control adjustment, load variations, signal variation, environmental conditions, and variations in characteristics of the device under consideration and of all other electronic devices in the equipment.



DESIGN MAXIMUM RATING SYSTEM

Design maximum ratings are limiting values of operating and environmental conditions applicable to a bogey electronic device of a specified type as defined by its published data, and should not be exceeded under the worst probable conditions.

These values are chosen by the device manufacturer to provide acceptable serviceability of the device, taking responsibility for the effects of changes in operating conditions due to variations in the characteristics of the electronic device under consideration.

The equipment manufacturer should design so that, initially and throughout life, no design maximum value for the intended service is exceeded with a bogey device under the worst probable operating conditions with respect to supply voltage variation, equipment component variation, variation in characteristics of all other devices in the equipment, equipment control adjustment, load variation, signal variation and environmental conditions.

DESIGN CENTRE RATING SYSTEM

Design centre ratings are limiting values of operating and environmental conditions applicable to a bogey electronic device of a specified type as defined by its published data, and should not be exceeded under normal conditions.

These values are chosen by the device manufacturer to provide acceptable serviceability of the device in average applications, taking responsibility for normal changes in operating conditions due to rated supply voltage variation, equipment component variation, equipment control adjustment, load variation, signal variation, environmental conditions, and variations in the characteristics of all electronic devices.

The equipment manufacturer should design so that, initially, no design centre value for the intended service is exceeded with a bogey electronic device in equipment operating at the stated normal supply voltage.

**GUNN, IMPATT
AND NOISE DIODES B**





B

SILICON AVALANCHE NOISE DIODE

Epitaxial, silicon planar, broadband noise generator. This is a current controlled device operated at avalanche breakdown and is effective from less than 10 Hz to above J-band. Applications include built-in test equipment (BITE) for surveillance, tracking and weather radars, microwave links, direction finding, p.c.m. systems and noise modulators for electronic countermeasures. It conforms to the environmental requirements of BS9300 where applicable and can be supplied to NATO stock No. 5691-99-038-3893.

QUICK REFERENCE DATA

Frequency range		<10 Hz to >18	GHz
Avalanche voltage	min.	17	V
	max.	22	V
Recommended operating current range		0.5 to 40	mA
Broadband excess noise ratio (figs. 1 and 3)	typ.	34	dB

This data must be read in conjunction with GENERAL SAFETY RECOMMENDATIONS – MICROWAVE SEMICONDUCTORS

MECHANICAL DATA

Dimensions in mm ←

Conforms to BS3934 SO-86 and to SOD-31

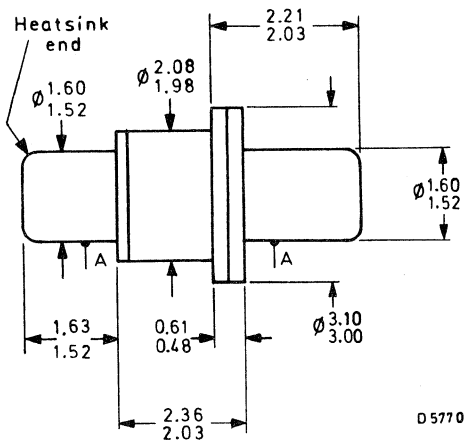

A = concentricity tolerance = ± 0.13



Normal operation with reverse bias, i.e. heatsink end positive.

RATINGS

Limiting values in accordance with the Absolute Maximum System (IEC134)

Storage temperature range	T_{stg}	-55 to +150	°C
Mounting base temperature	T_{mb}	max. 80	°C
Reverse current	I_R	max. 40	mA
Total power dissipation	P_{tot}	max. 1.0	W

CHARACTERISTICS ($T_{mb} = 25\text{ °C}$)

Broadband excess noise ratio (figs. 1 and 3)		typ.	34	dB
Reverse breakdown voltage at $I_R = 5\text{ mA}$	$V_{BR(R)}$	min.	17	V
Junction capacitance at $V_R = 6\text{ V}$, $f = 1\text{ MHz}$	C_j	min.	0.4	pF
		max.	0.8	pF
Reverse current at $V_R = 6\text{ V}$	I_R	max.	0.1	μA
Reverse slope resistance at $I_R = 40\text{ mA}$, $f = 1\text{ kHz}$ (note 1)	R_{slope}	max.	60	Ω
$\frac{R_1}{R_{40}}$ at $I_R = 1\text{ mA}$ and 40 mA , $f = 1\text{ kHz}$ (note 1)		max.	2.5	
Stray capacitance	C_s	typ.	0.2	pF
Series inductance	L_s	typ.	650	pH

Notes

- R_{slope} is the reverse slope resistance and $\frac{R_1}{R_{40}}$ is the ratio of the reverse slope resistance at 1 mA and

40 mA, measured at 1 kHz. This ratio is included in the characteristics to eliminate spurious effects in the noise output/current characteristic.

The reverse slope resistance consists of the space charge resistance R_{sc} , the spreading resistance R_{sp} and the 'thermal resistance' R_{th} , i.e.

$$R_{slope} = R_{sc} + R_{sp} + R_{th}$$

where: R_{sc} is approximately 10 Ω at 10 to 40 mA and 19 Ω at 1 mA

R_{sp} is approximately 1 Ω

R_{th} is the effective resistance due to isothermal heating in the device when operated with an infinite heatsink. Above 10 MHz, R_{th} may be neglected.

- The location of the top cap should be a hole of diameter 1.8 to 2.2 mm, bearing on flange with a force not exceeding 10 N.
- Other encapsulations may be made available on request.

APPLICATION INFORMATION

The device, as characterised, is operated in a $50\ \Omega$ characteristic impedance measurement system. When used as a noise source in an on-off mode, the device, when off, should appear to be $50\ \Omega$. Since it has a large reflection coefficient when zero biased or biased just below avalanche breakdown, sufficient attenuation is required to provide a reasonable match to $50\ \Omega$. For the broadest operating frequency range, an attenuator of approximately 14 dB with a v.s.w.r. of $<1.2:1$ is recommended. This will reduce the available excess noise by 14 dB. Higher excess noise may be obtained, but over a reduced operating frequency range, in a balanced configuration with low noise directional couplers (e.g. a 3 dB quadrature coupler), or fed into a broadband ferrite isolator (or terminated circulator) which would reduce the available excess noise by approximately 1 dB.

Temperature and excess noise relationship

Excess noise dB	Noise temperature $^{\circ}\text{K}$	1 Hz bandwidth dBm	1 MHz bandwidth dBm
+100	2.9×10^{12}	-74	-14
+90	2.9×10^{11}	-84	-24
+80	2.9×10^{10}	-94	-34
+70	2.9×10^9	-104	-44
+60	2.9×10^8	-114	-54
+50	2.9×10^7	-124	-64
+40	2.9×10^6	-134	-74
+30	2.9×10^5	-144	-84
+20	2.9×10^4	-154	-94
+10	2.9×10^3	-164	-104
0	2.9×10^2	-174	-114

The device may be pulse operated with a rise time of $\ll 0.5\ \mu\text{s}$

The device should be operated from a constant current source, however, good results may be achieved using a 28 V supply and typically a metal film or wirewound $1.6\ \text{k}\Omega$ resistor in series with the noise diode, with suitable power supply decoupling.

In some applications, current profiling with time may be useful, i.e. linear excess noise ratio as a function of log bias current as shown in fig.1. This may be used for receiver sensitivity measurement on a P.P.I. display.



— Recommended bias range for broadband operation up to 12.4 GHz

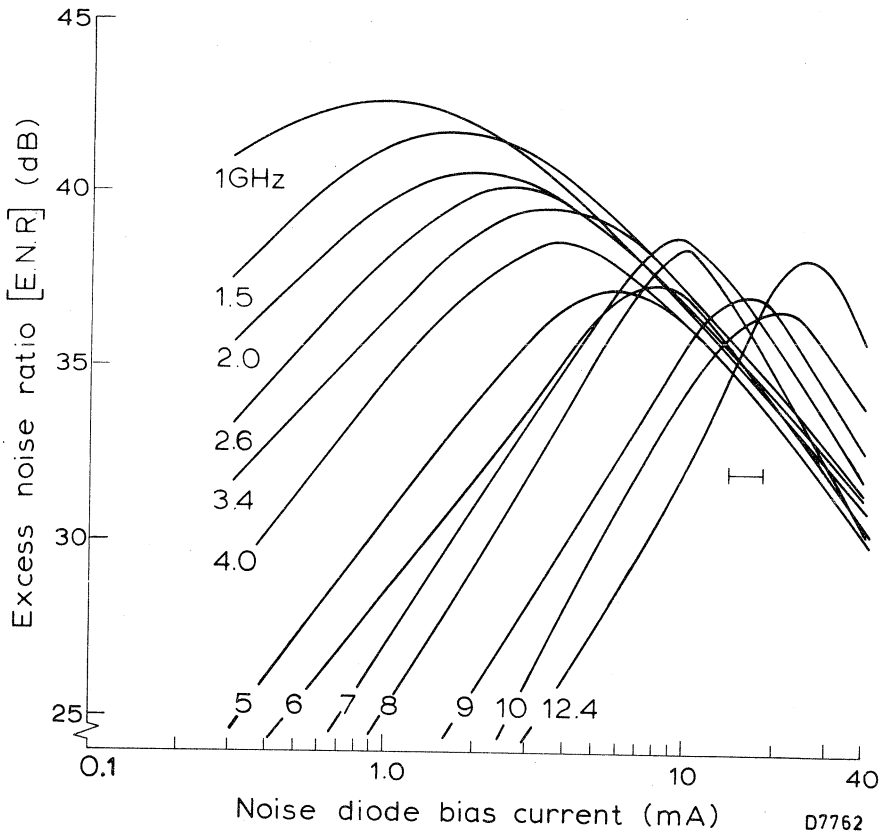
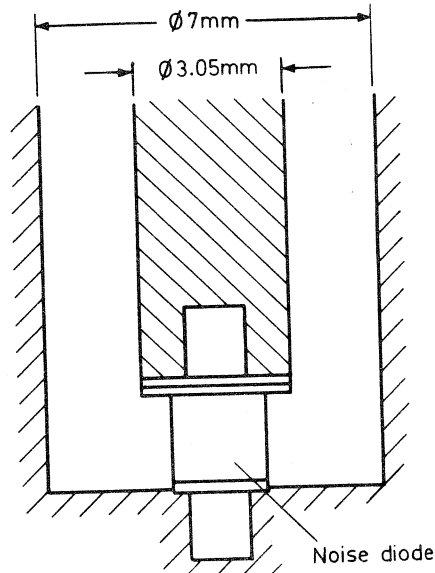

Fig.1

Typical excess noise ratio as a function of avalanche current with frequency as a parameter.
Device mounted in a 50 Ω 7 mm coaxial line as shown in Fig.2



D7763

Fig.2

Device mounted in a 50 Ω 7 mm coaxial line

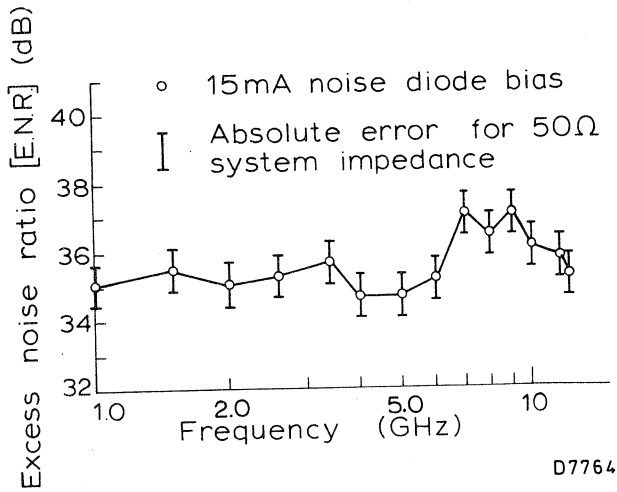

D7764

Fig.3

Typical broadband noise performance for an avalanche current of 15 mA with device mounted as shown in Fig.2

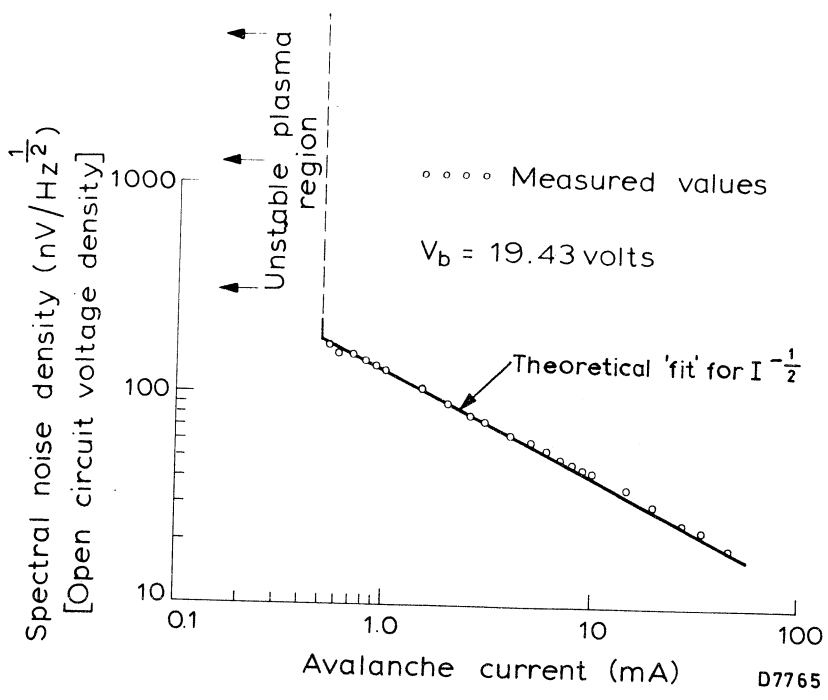

Fig.4

Typical broadband noise density measured over a 1 kHz to 10 kHz bandwidth.

SILICON IMPATT DIODE

A high efficiency silicon Impatt diode for the generation of c.w. power at microwave frequencies. It conforms to the environmental requirements of BS9300 where applicable.

QUICK REFERENCE DATA

Operating frequency	f	8.0 to 10	GHz
Output power, $T_{HS} = 35\text{ }^{\circ}\text{C}$	P_{out}	typ. 600	mW
Operating current		typ. 135	mA
Operating voltage		typ. 91	V

This data must be read in conjunction with GENERAL SAFETY RECOMMENDATIONS — MICROWAVE SEMICONDUCTORS

MECHANICAL DATA

Dimensions in mm

Conforms to SOD-45

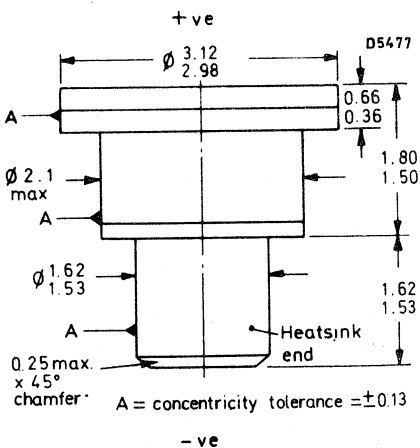

Devices may be selected to suit customers' specific requirements

RATINGS

Limiting values in accordance with the Absolute Maximum System (IEC134)

Storage temperature range	T_{stg}	-55 to +175	°C
Junction to heatsink temperature diff.	$T_j - T_{hs}$	max. 165	°C
Total power dissipation (note 1)	P_{tot}	max. $\frac{200 - T_{hs}}{R_{th\ j-hs}}$	W

THERMAL RESISTANCE

Thermal resistance from junction to heatsink	$R_{th\ j-hs}$	max. 15	°C/W
--	----------------	---------	------

CHARACTERISTICS ($T_{hs} = 25\text{ °C}$)

		min.	typ.	max.	
Reverse breakdown voltage $I_R = 1.0\text{ mA}$	$V_{(BR)R}$	65	75	85	V
Reverse current $V_R = 50\text{ V}$	I_R	—	—	10	μA
Total capacitance $V_{(BR)R} = -5\text{ V}$	C_T	—	0.9	—	pF

TYPICAL OSCILLATOR PERFORMANCE

Operating current (note 2)		—	135	—	mA
Operating voltage		—	91	—	V
Frequency (note 3)	f	8.0	—	10	GHz
Output power (notes 2, 4, 5 and 6)	P_{out}	500	600	—	mW
Efficiency	η	—	5.0	—	%

Notes

1. The maximum junction temperature is 200 °C, therefore care must be taken to ensure that

$$P_{tot\ max.} \leq \frac{200 - T_{hs}}{R_{th\ j-hs}} \text{ W,}$$

where $P_{tot} = P_{in} - P_{out}$

T_{hs} = temperature of heatsink at interface with device

$R_{th\ j-hs}$ = thermal resistance from junction to heatsink in which device is clamped.

2. The bias supply should be current regulated to within 1% and care should be taken to avoid transient current surges which could cause burn-out. The bias circuit should be arranged to present a high impedance at d.c. to v.h.f. frequencies. This will help to prevent oscillation in the bias circuit and noisy operation. Particular care should be taken to minimise stray capacitances across the diode. The maximum power supply requirements are 115 V and 160 mA
3. The frequency is governed by the choice of cavity to which the device is coupled.
4. The polarity of the device must be strictly observed when applying bias, (see outline drawing).
5. The output power is normally measured in a coaxial cavity near to centre band frequency.

6. The heatsink end of the device should be held in a collet or equivalent clamping system to ensure minimum thermal resistance in the path to the mounting base. This in turn must be coupled to an adequate heatsink. Alternatively, direct soldering, using a low melting point solder, or an electrically conductive single loaded epoxy, such as Epotek H40, may be used.
7. This device may be used as a negative resistance amplifier.

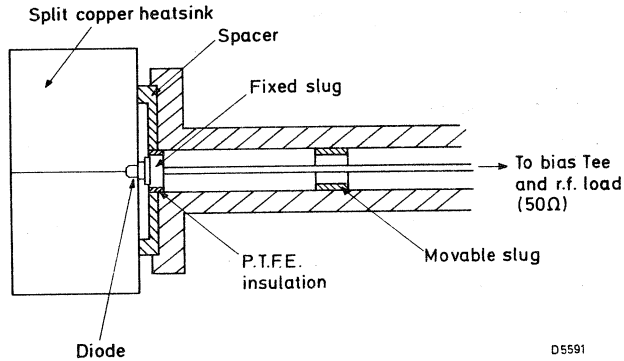

Coaxial test oscillator cavity

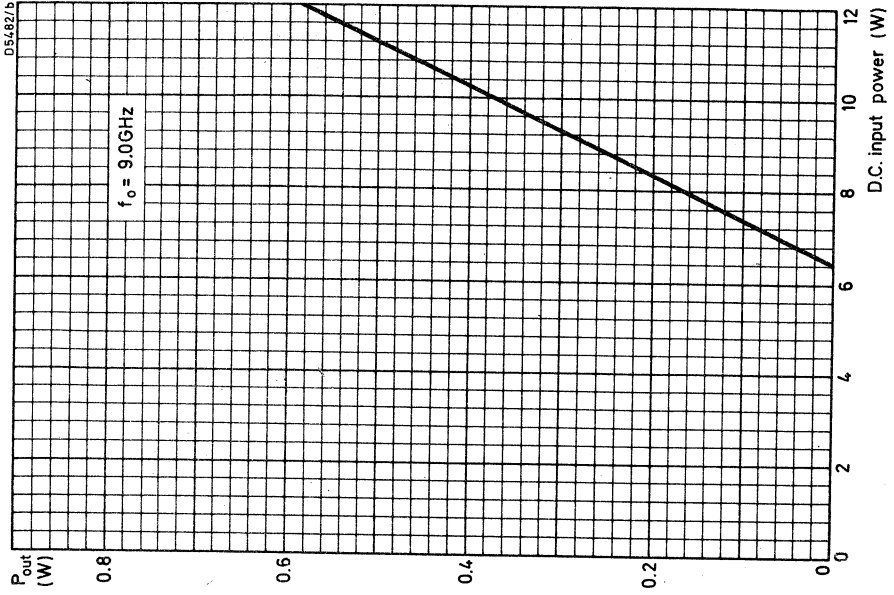

Typical output power as a function of d.c. input power

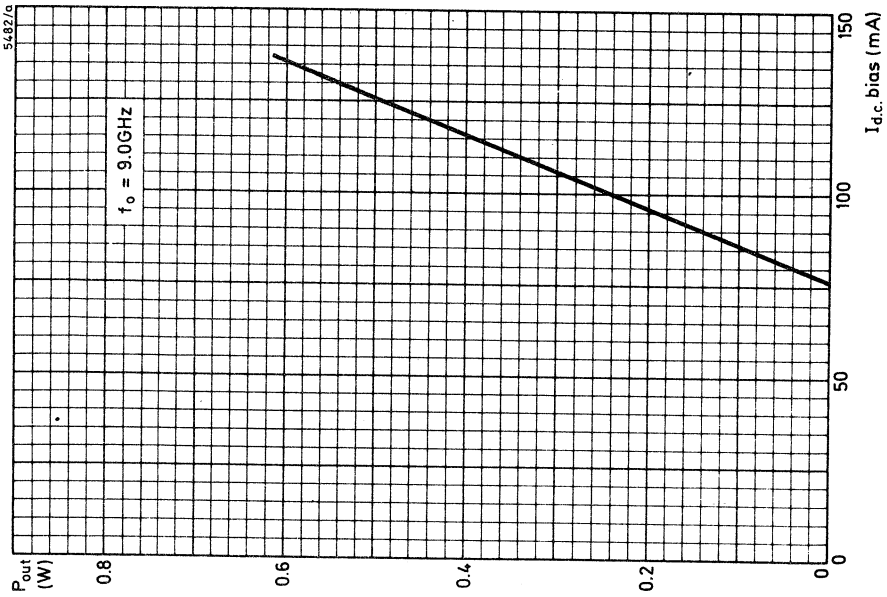

Typical output power as a function of bias current

SILICON IMPATT DIODE

A high efficiency silicon Impatt diode for the generation of c.w. power at microwave frequencies. It conforms to the environmental requirements of BS9300 where applicable.

QUICK REFERENCE DATA

Operating frequency	f	10 to 12	GHz
Output power, $T_{hs} = 35\text{ }^{\circ}\text{C}$	P_{out}	typ. 450	mW
Operating current		typ. 120	mA
Operating voltage		typ. 80	V

This data must be read in conjunction with GENERAL SAFETY RECOMMENDATIONS – MICROWAVE SEMICONDUCTORS

Dimensions in mm

MECHANICAL DATA

Conforms to SOD-45

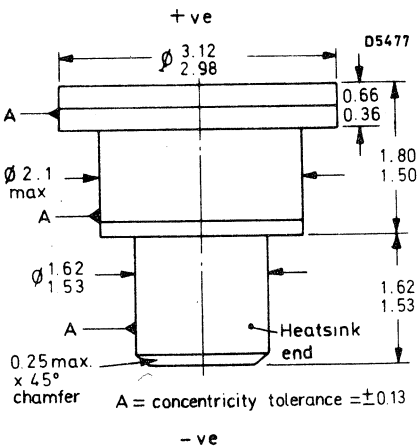

Devices may be selected to suit customers' specific requirements.

RATINGS

Limiting values in accordance with the Absolute Maximum System (IEC134)

Storage temperature range	T_{stg}	-55 to +175	°C
Junction to heatsink temperature diff.	$T_j - T_{hs}$	max. 165	°C
Total power dissipation (note 1)	P_{tot}	max. $\frac{200 - T_{hs}}{R_{th\ j-hs}}$	W

THERMAL RESISTANCE

Thermal resistance from junction to heatsink	$R_{th\ j-hs}$	max. 19	°C/W
--	----------------	---------	------

CHARACTERISTICS ($T_{hs} = 25\text{ °C}$)

		min.	typ.	max.	
Reverse breakdown voltage $I_R = 1.0\text{ mA}$	$V_{(BR)R}$	55	65	75	V
Reverse current $V_R = 45\text{ V}$	I_R	-	-	10	μA
Total capacitance $V_{(BR)R} = -5\text{ V}$	C_T	-	0.85	-	pF

TYPICAL OSCILLATOR PERFORMANCE

Operating current (note 2)		-	120	-	mA
Operating voltage		-	80	-	V
Frequency (note 3)	f	10	-	12	GHz
Output power (notes 2,4,5 and 6)	P_{out}	400	450	-	mW
Efficiency	η	-	5.0	-	%

Notes

1. The maximum junction temperature is 200 °C, therefore care must be taken to ensure that

$$P_{tot\ max.} \leq \frac{200 - T_{hs}}{R_{th\ j-hs}} \text{ W,}$$

where $P_{tot} = P_{in} - P_{out}$

T_{hs} = temperature of heatsink at interface with device

$R_{th\ j-hs}$ = thermal resistance from junction to heatsink in which device is clamped.

2. The bias supply should be current regulated to within 1% and care should be taken to avoid transient current surges which could cause burn-out. The bias circuit should be arranged to present a high impedance at d.c. to v.h.f. frequencies. This will help to prevent oscillation in the bias circuit and noisy operation. Particular care should be taken to minimise stray capacitances across the diode. The maximum power supply requirements are 105 V and 170 mA
3. The frequency is governed by the choice of cavity to which the device is coupled.
4. The polarity of the device must be strictly observed when applying bias, (see outline drawing).
5. The output power is normally measured in a coaxial cavity near to centre band frequency.

6. The heatsink end of the device should be held in a collet or equivalent clamping system to ensure minimum thermal resistance in the path to the mounting base. This in turn must be coupled to an adequate heatsink. Alternatively, direct soldering, using a low melting point solder, or an electrically conductive single loaded epoxy, such as Epotek H40, may be used.
7. This device may be used as a negative resistance amplifier.

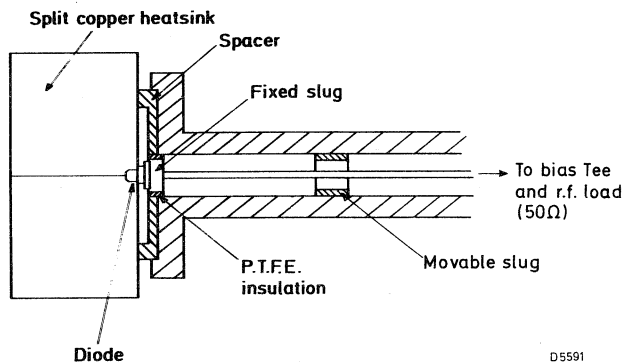

Coaxial test oscillator cavity

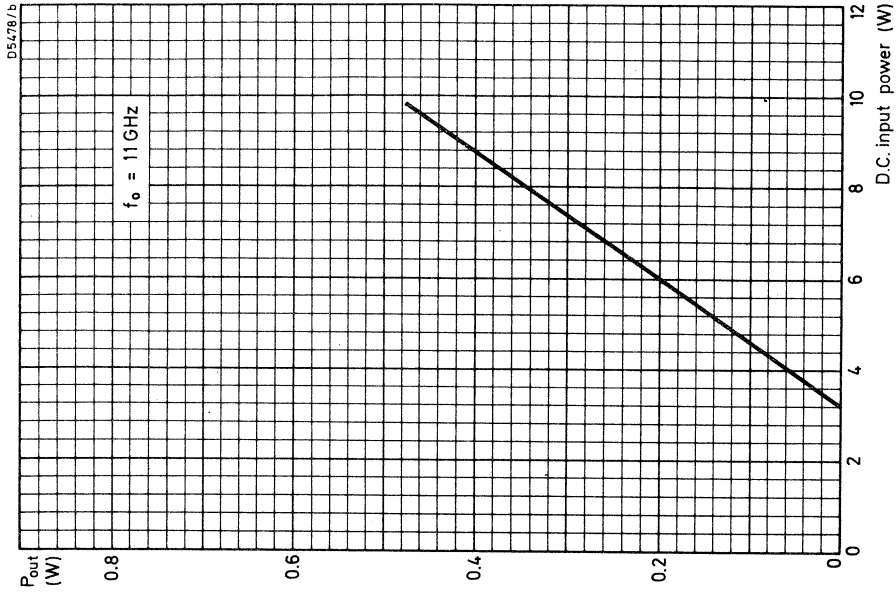

Typical output power as a function of d.c. input power

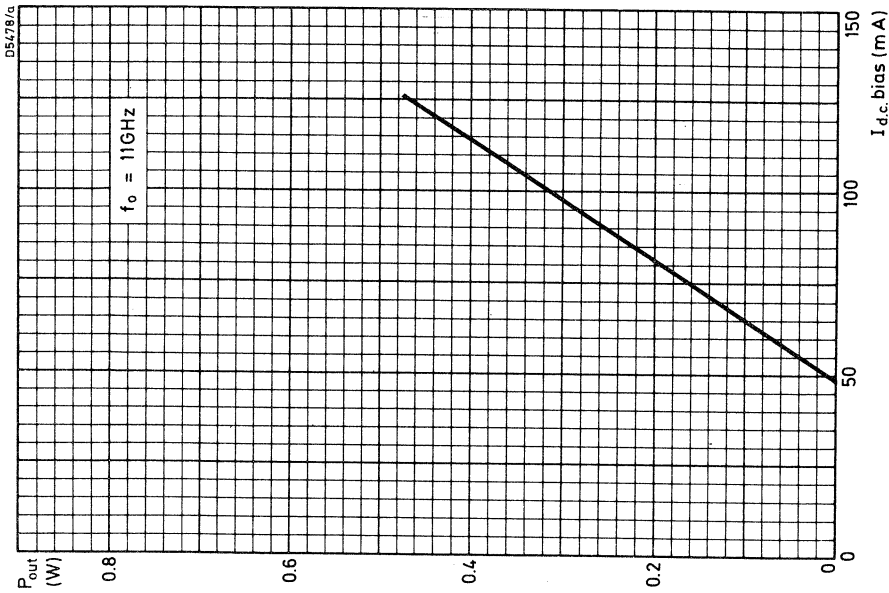

Typical output power as a function of bias current

SILICON IMPATT DIODE

A high efficiency silicon Impatt diode for the generation of c.w. power at microwave frequencies. It conforms to the environmental requirements of BS9300 where applicable.

QUICK REFERENCE DATA

Operating frequency	f		12 to 14	GHz
Output power, $T_{hs} = 35\text{ }^{\circ}\text{C}$	P_{out}	typ.	370	mW
Operating current		typ.	120	mA
Operating voltage		typ.	70	V

This data must be read in conjunction with GENERAL SAFETY RECOMMENDATIONS – MICROWAVE SEMICONDUCTORS

MECHANICAL DATA

Dimensions in mm

Conforms to SOD-45

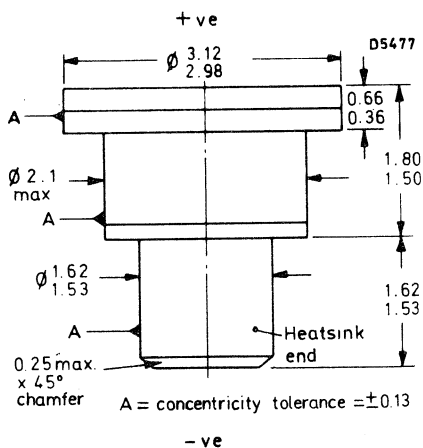

Devices may be selected to suit customers' specific requirements.

RATINGS

Limiting values in accordance with the Absolute Maximum System (IEC134)

Storage temperature range	T_{stg}	-55 to +175	°C
Junction to heatsink temperature diff.	$T_j - T_{hs}$	max. 165	°C
Total power dissipation (note 1)	P_{tot}	max. $\frac{200 - T_{hs}}{R_{th\ j-hs}}$	W

THERMAL RESISTANCE

Thermal resistance from junction to heatsink	$R_{th\ j-hs}$	max. 24	°C/W
--	----------------	---------	------

CHARACTERISTICS ($T_{hs} = 25\text{ °C}$)

		min.	typ.	max.	
Reverse breakdown voltage $I_R = 1.0\text{ mA}$	$V_{(BR)R}$	50	55	60	V
Reverse current $V_R = 40\text{ V}$	I_R	-	-	10	µA
Total capacitance $V_{(BR)R} = -5\text{ V}$	C_T	-	0.75	-	pF

TYPICAL OSCILLATOR PERFORMANCE

Operating current (note 2)		-	120	-	mA
Operating voltage		-	70	-	V
Frequency (note 3)	f	12	-	14	GHz
Output power (notes 2, 4, 5 and 6)	P_{out}	300	370	-	mW
Efficiency	η	-	4.5	-	%

Notes

1. The maximum junction temperature is 200 °C, therefore care must be taken to ensure that

$$P_{tot\ max.} \leq \frac{200 - T_{hs}}{R_{th\ j-hs}}\ W,$$

where $P_{tot} = P_{in} - P_{out}$

T_{hs} = temperature of heatsink at interface with device

$R_{th\ j-hs}$ = thermal resistance from junction to heatsink in which device is clamped.

2. The bias supply should be current regulated to within 1% and care should be taken to avoid transient current surges which could cause burn-out. The bias circuit should be arranged to present a high impedance at d.c. to v.h.f. frequencies. This will help to prevent oscillation in the bias circuit and noisy operation. Particular care should be taken to minimise stray capacitances across the diode. The maximum power supply requirements are 90 V and 150 mA
3. The frequency is governed by the choice of cavity to which the device is coupled.
4. The polarity of the device must be strictly observed when applying bias, (see outline drawing).
5. The output power is normally measured in a coaxial cavity near to centre band frequency.

6. The heatsink end of the device should be held in a collet or equivalent clamping system to ensure minimum thermal resistance in the path to the mounting base. This in turn must be coupled to an adequate heatsink. Alternatively, direct soldering, using a low melting point solder, or an electrically conductive single loaded epoxy, such as Epotek H40, may be used.
7. This device may be used as a negative resistance amplifier.

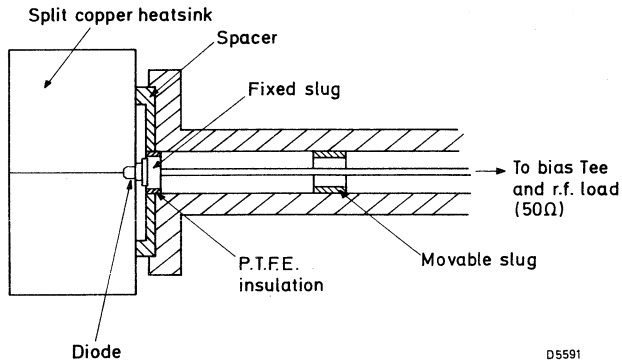

Coaxial test oscillator cavity

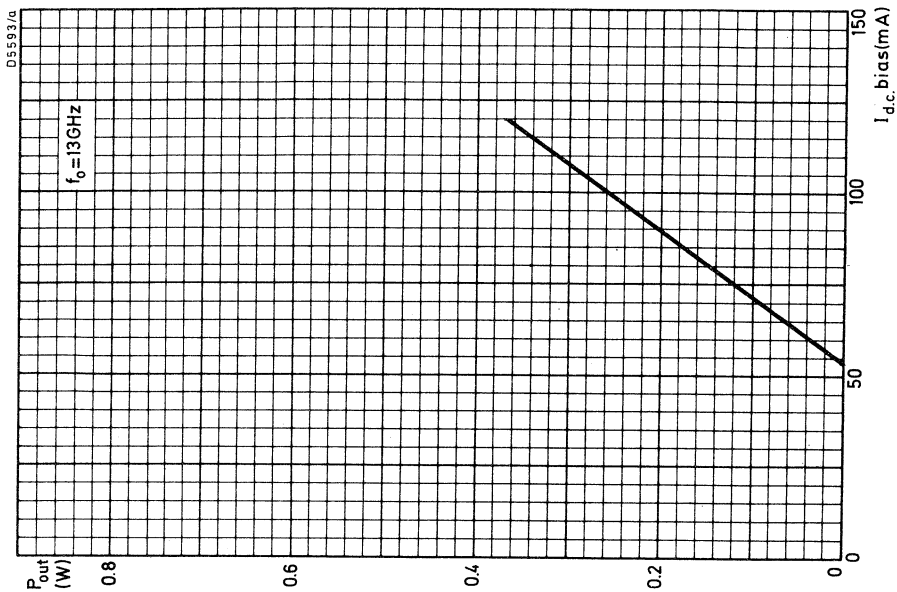

Typical output power as a function of d.c. input power

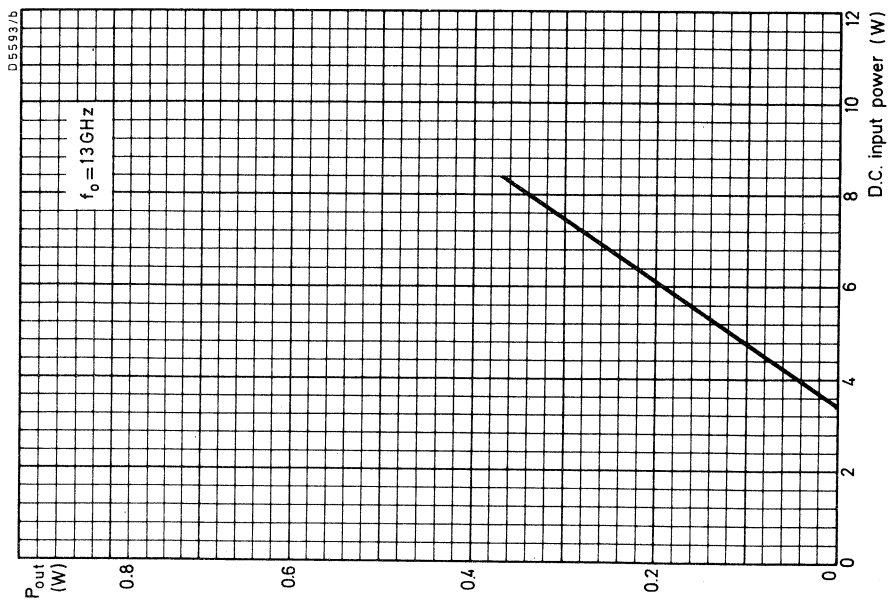

Typical output power as a function of bias current

SILICON IMPATT DIODE

A high efficiency silicon Impatt diode for the generation of c.w. power at microwave frequencies. It conforms to the environmental requirements of BS9300 where applicable.

QUICK REFERENCE DATA

Operating frequency		6.0 to 8.0	GHz
Output power, $T_{hs} = 35\text{ }^{\circ}\text{C}$	P_{out}	typ. 750	mW
Operating current		typ. 125	mA
Operating voltage		typ. 120	V

This data must be read in conjunction with GENERAL SAFETY RECOMMENDATIONS – MICROWAVE SEMICONDUCTORS

MECHANICAL DATA

Dimensions in mm

Conforms to SOD-45

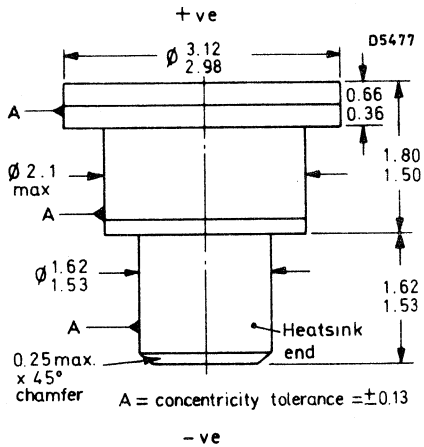

Devices may be selected to suit customers' specific requirements, including alternative packages.

RATINGS

Limiting values in accordance with the Absolute Maximum System (IEC134)

Storage temperature range	T_{stg}	-55 to +175	°C
Junction temperature	T_j	max. 200	°C
Junction to heatsink temperature diff.	$T_j - T_{hs}$	165	°C
Total power dissipation (note 1)	P_{tot}	max. $\frac{200 - T_{hs}}{R_{th\ j-hs}}$	W

THERMAL RESISTANCE

Thermal resistance from junction to heatsink	$R_{th\ j-hs}$	max. 14	°C/W
--	----------------	---------	------

CHARACTERISTICS ($T_{hs} = 25\text{ °C}$)

Reverse breakdown voltage $I_R = 1.0\text{ mA}$	$V_{(BR)R}$	min. 85	typ. 100	max. 115	V
Reverse current $V_R = 70\text{ V}$	I_R	—	—	10	μA
Total capacitance $V_{(BR)R} = 75\text{ V}$	C_T	—	0.97	—	pF

TYPICAL OSCILLATOR PERFORMANCE

Operating current (note 2)		—	125	—	mA
Operating voltage		—	120	—	V
Frequency (note 3)	f	6.0	—	8.0	GHz
Output power (notes 2, 4, 5 and 6)	P_{out}	650	750	—	mW
Efficiency	η	—	5.0	—	%

Notes

1. The maximum junction temperature is 200 °C, therefore care must be taken to ensure that

$$P_{tot\ max.} \leq \frac{200 - T_{hs}}{R_{th\ j-hs}}\ W,$$

where $P_{tot} = P_{in} - P_{out}$

T_{hs} = temperature of heatsink at interface with device

$R_{th\ j-hs}$ = thermal resistance from junction to heatsink in which device is clamped.

2. The bias supply should be current regulated to within 1% and care should be taken to avoid transient current surges which could cause burn-out. The bias circuit should be arranged to present a high impedance at d.c. to v.h.f. frequencies. This will help to prevent oscillation in the bias circuit and noisy operation. Particular care should be taken to minimise stray capacitances across the diode. The maximum power supply requirements are 140 V and 180 mA.
3. The frequency is governed by the choice of cavity to which the device is coupled.
4. The polarity of the device must be strictly observed when applying bias, (see outline drawing).
5. The output power is normally measured in a coaxial cavity near to centre band frequency.

6. The heatsink end of the device should be held in a collet or equivalent clamping system to ensure minimum thermal resistance in the path to the mounting base. This in turn must be coupled to an adequate heatsink. Alternatively, direct soldering, using a low melting point solder, or an electrically conductive single loaded epoxy, such as Epotek H40, may be used.
7. This device may be used as a negative resistance amplifier.

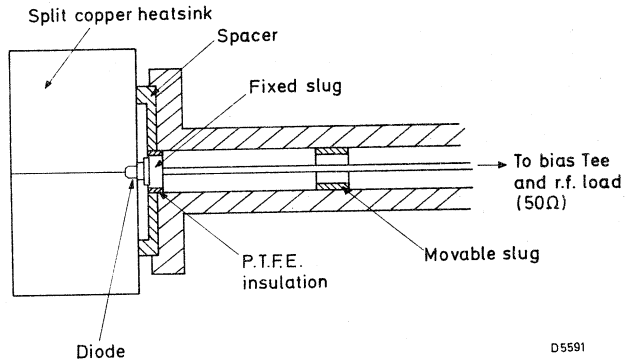

Coaxial test oscillator cavity

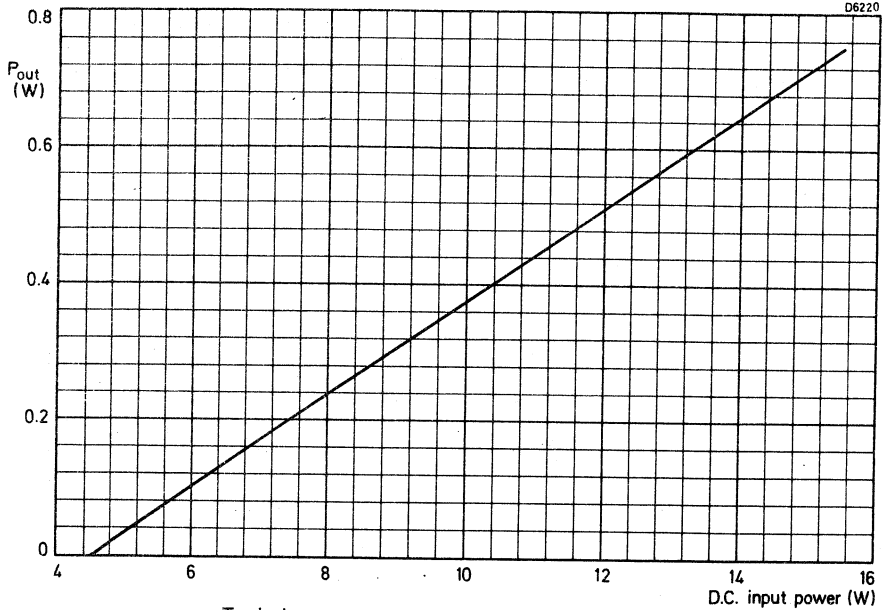

Typical output power as a function of d.c. input power

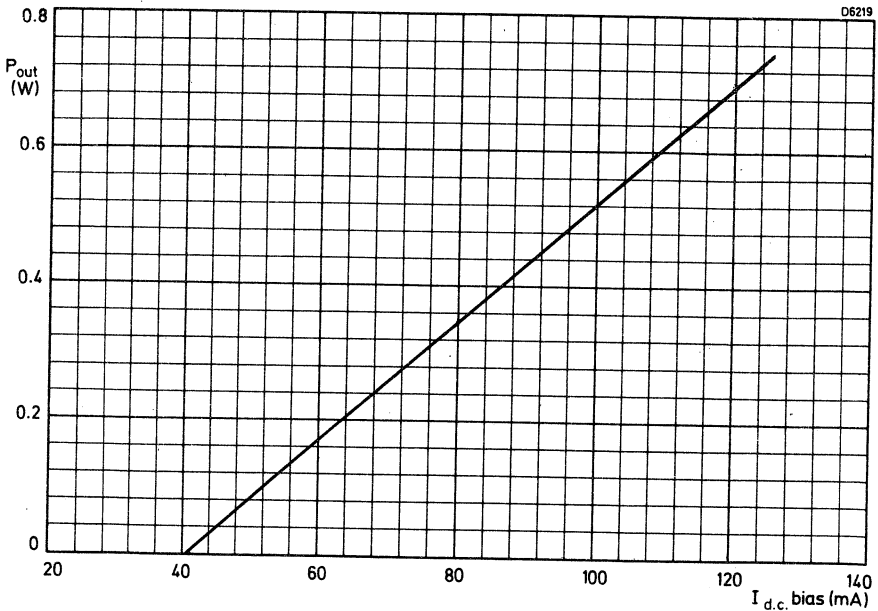

Typical output power as a function of bias current

GUNN EFFECT DEVICES

Gallium arsenide bulk effect devices employing the Gunn effect to produce c.w. oscillations at microwave frequencies. Each device is encapsulated in a standard microwave package and conforms to the environmental requirements of BS9300 where applicable.

QUICK REFERENCE DATA

Operating frequency range		f	8.0 to 12	GHz
Operating voltage		V	typ.	7.0 V
Total power dissipation, $T_{mb} = 70\text{ }^{\circ}\text{C}$		P_{tot}	max.	1.0 W
Output power	CXY11A	P_{out}	min.	5.0 mW
	CXY11B			10 mW
	CXY11C			15 mW

Unless otherwise stated, data is applicable to all types.

This data must be read in conjunction with GENERAL SAFETY RECOMMENDATIONS – MICROWAVE SEMICONDUCTORS

MECHANICAL DATA

Dimensions in mm

Conforms to SOD-31

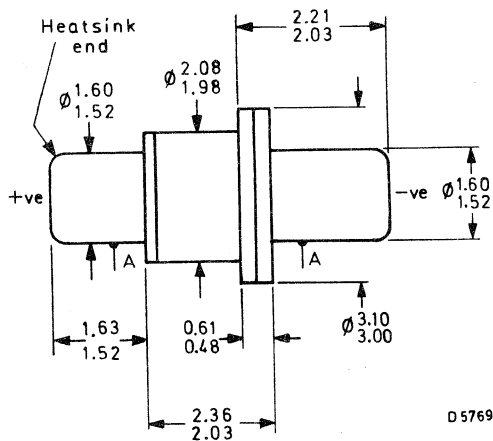

D 5769

A = concentricity tolerance = ± 0.13

Complete oscillators using these devices are available
 Devices may be selected to suit customers' specific requirements.

RATINGS

Limiting values in accordance with the Absolute Maximum System (IEC134)

Storage temperature range	T_{stg}		-55 to +150	°C
Mounting base temperature range	T_{mb}		-40 to +70	°C
Operating voltage (note 1)	V	max.	7.5	V
Operating voltage for less than 1 ms	V	max.	9.0	V
Total power dissipation, $T_{mb} = 70$ °C	P_{tot}	max.	1.0	W

CHARACTERISTICS ($T_{amb} = 25$ °C)

		min.	typ.	max.	
Bias current, V = 7.0 V (note 1)	I_{dc}	-	120	150	mA
Operating frequency (note 2)	f	8.0	9.5	12	GHz
Output power, V = 7.0 V (note 3)	P_{out}	CXY11A	5.0	8.0	-
		CXY11B	10	12	-
		CXY11C	15	20	-
A.M. noise to output power ratio (note 4)		-90	-100	-	dB

Notes

1. Bias must be applied in such a way that the mounting base (heatsink end) of the device is always positive. Reversing the polarity may cause permanent damage. Care should be taken to protect the device from transients. An 8.2 V voltage regulator diode to shunt the power supply is recommended for this purpose.
2. The frequency is governed by the choice of cavity to which the device is coupled.
3. The output power is normally measured in a coaxial cavity at a frequency of 9.5 GHz. Other centre frequencies may be supplied at 8.5, 10.5 and 11.5 GHz by suffixing the type number e.g. CXY11B/10.5 specifies a diode giving 10 mW min. at 10.5 GHz. See the table below. Diodes with these other centre frequencies will not necessarily oscillate over the whole 8 to 12 GHz range. The bias may be optimized to give maximum output power within the V max. and P_{tot} max. ratings.
4. A.M. noise is measured in a 1 Hz to 1 kHz bandwidth with the diode mounted in a CL8630 oscillator.
5. It is important to ensure good thermal contact between the device and the mounting base, which in turn should be coupled to an adequate heatsink.
6. The power supply should be low impedance, voltage regulated and capable of supplying approximately 1.5 times the normal current, to initiate oscillation.

Minimum output power (mW)	Test frequency (GHz)			
	8.5	9.5	10.5	11.5
5	CXY11A/8.5	CXY11A	CXY11A/10.5	CXY11A/11.5
10	CXY11B/8.5	CXY11B	CXY11B/10.5	CXY11B/11.5
15	CXY11C/8.5	CXY11C	CXY11C/10.5	CXY11C/11.5

RATINGS

Limiting values in accordance with the Absolute Maximum System (IEC134)

Storage temperature range	T_{stg}		-55 to +150	°C
Mounting base temperature range	T_{mb}		-40 to +70	°C
Operating voltage	V	max.	7.5	V
Operating voltage for less than 1 ms	V	max.	9.0	V
Total power dissipation, $T_{mb} = 70$ °C	P_{tot}	max.	1.0	W

CHARACTERISTICS ($T_{amb} = 25$ °C)

		min.	typ.	max.		
Bias current, $V = 7.0$ V (note 1)	I_{dc}	—	120	145	mA	
Operating frequency (note 2)	f	12	14	18	GHz	
Output power, $V = 7.0$ V (note 3)	CXY14A CXY14B CXY14C	P_{out}	5.0	8.0	—	mW
			10	12	—	mW
			15	20	—	mW

Notes

1. Bias must be applied in such a way that the mounting base (heatsink end) of the device is always positive. Reversing the polarity may cause permanent damage. Care should be taken to protect the device from transients. An 8.2 V voltage regulator diode to shunt the power supply is recommended for this purpose.
2. The frequency is governed by the choice of cavity to which the device is coupled.
3. The output power is normally measured in a coaxial cavity at approximately centre-band frequency. The bias may be optimized to give maximum output power within the V max. and P_{tot} max. ratings.
4. It is important to ensure good thermal contact between the device and the mounting base, which in turn should be coupled to an adequate heatsink.
5. The power supply should be low impedance, voltage regulated and capable of supplying approximately 1.5 times the normal current, to initiate oscillation.

GUNN EFFECT DEVICE

Gallium arsenide bulk effect device employing the Gunn effect to produce c.w. oscillations at microwave frequencies. Each device is encapsulated in a standard microwave package and conforms to the environmental requirements of BS9300 where applicable.

QUICK REFERENCE DATA

Operating frequency range	f	8.0 to 12	GHz
Operating voltage (note 2)	V	8.0 to 12	V
Total power dissipation, $T_{mb} = 70^{\circ}\text{C}$	P_{tot}	max.	6.0 W
Output power, $f = 9.5\text{ GHz}$	P_{out}	min.	100 mW

This data must be read in conjunction with GENERAL SAFETY RECOMMENDATIONS – MICROWAVE SEMICONDUCTORS

MECHANICAL DATA

Dimensions in mm

Conforms to SOD-31

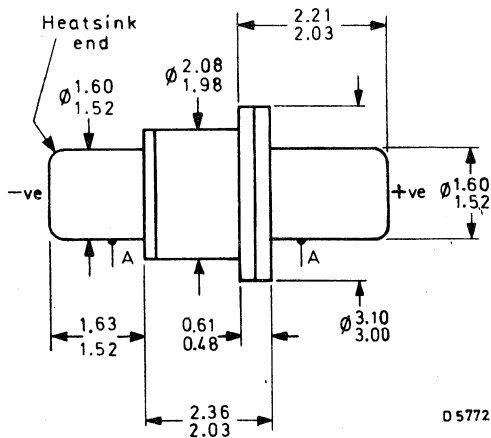

A = concentricity tolerance = ± 0.13

All dimensions in mm

Devices may be selected to suit customers' specific requirements.

RATINGS

Limiting values in accordance with the Absolute Maximum System (IEC134)

Storage temperature range	T_{stg}		-55 to +150	°C
Mounting base temperature range	T_{mb}		-40 to +70	°C
Operating voltage (note 1)	V	max.	12	V
Operating voltage for less than 1 ms	V	max.	14	V
Total power dissipation, $T_{mb} = 70\text{ °C}$	P_{tot}	max.	6.0	W

CHARACTERISTICS ($T_{amb} = 25\text{ °C}$)

		min.	typ.	max.	
Bias current (notes 1 and 2)	I_{dc}	—	450	750	mA
Threshold current		—	—	1.0	A
Operating frequency (note 3)	f	8.0	9.5	12	GHz
Output power (note 2)	P_{out}	100	150	—	mW

Notes

1. Bias must be applied in such a way that the mounting base (heatsink end) of the device is always negative. Reversing the polarity may cause permanent damage. Care should be taken to protect the device from transients.
2. Each device is measured for maximum output power at 9.5 GHz in a coaxial test cavity. The bias is optimized for this maximum within the V max. and P_{tot} max. ratings. The operating voltage and corresponding current are quoted for this condition on a test record supplied with each device.
3. The frequency is governed by the choice of cavity to which the device is coupled.
4. The heatsink end of the device should be held in a collet or equivalent clamping system to ensure minimum thermal resistance in the path to the mounting base. This in turn must be coupled to an adequate heatsink. Alternatively, direct soldering, using a low melting point solder, or an electrically conductive single loaded epoxy, such as Epotek H40, may be used.
5. The power supply should be low impedance, voltage regulated and capable of supplying approximately 1.5 times the normal current, to initiate oscillation.

GUNN EFFECT DEVICE

Gallium arsenide bulk effect device employing the Gunn effect to produce c.w. oscillations at microwave frequencies. Each device is encapsulated in a standard microwave package and conforms to the environmental requirements of BS9300 where applicable.

QUICK REFERENCE DATA

Operating frequency range	f	8.0 to 12	GHz
Operating voltage (note 2)	V	8.0 to 12	V
Total power dissipation, $T_{mb} = 70\text{ }^{\circ}\text{C}$	P_{tot}	max.	6.0 W
Output power, $f = 9.5\text{ GHz}$	P_{out}	min.	200 mW

This data must be read in conjunction with GENERAL SAFETY RECOMMENDATIONS – MICROWAVE SEMICONDUCTORS

MECHANICAL DATA

Dimensions in mm

Conforms to SOD-31

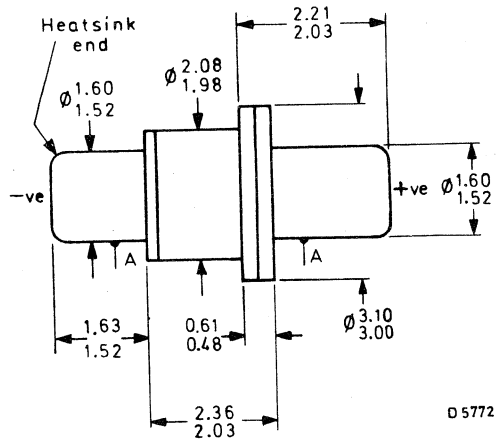

A = concentricity tolerance = ± 0.13

Devices may be selected to suit customers' specific requirements.

RATINGS

Limiting values in accordance with the Absolute Maximum System (IEC134)

Storage temperature range	T_{stg}		-55 to +150	°C
Mounting base temperature range	T_{mb}		-40 to +70	°C
Operating voltage (note 1)	V	max.	12	V
Operating voltage for less than 1 ms	V	max.	14	V
Total power dissipation, $T_{mb} = 70$ °C	P_{tot}	max.	6.0	W

CHARACTERISTICS ($T_{amb} = 25$ °C)

		min.	typ.	max.	
Bias current (notes 1 and 2)	I_{dc}	—	450	750	mA
Threshold current		—	—	1.0	A
Operating frequency (note 3)	f	8.0	9.5	12	GHz
Output power (note 2)	P_{out}	200	250	—	mW

Notes

1. Bias must be applied in such a way that the mounting base (heatsink end) of the device is always negative. Reversing the polarity may cause permanent damage. Care should be taken to protect the device from transients.
2. Each device is measured for maximum output power at 9.5 GHz in a coaxial test cavity. The bias is optimized for this maximum within the V max. and P_{tot} max. ratings. The operating voltage and corresponding current are quoted for this condition on a test record supplied with each device.
3. The frequency is governed by the choice of cavity to which the device is coupled.
4. The heatsink end of the device should be held in a collet or equivalent clamping system to ensure minimum thermal resistance in the path to the mounting base. This in turn must be coupled to an adequate heatsink. Alternatively, direct soldering, using a low melting point solder, or an electrically conductive single loaded epoxy, such as Epotek H40, may be used.
5. The power supply should be low impedance, voltage regulated and capable of supplying approximately 1.5 times the normal current, to initiate oscillation.

GUNN EFFECT DEVICE

Gallium arsenide bulk effect n+ sandwich device employing the Gunn effect to produce c.w. oscillations at microwave frequencies. Each device is encapsulated in a standard microwave package and conforms to the environmental requirements of BS9300 where applicable.

QUICK REFERENCE DATA

Operating frequency range	f	8.0 to 12	GHz
Operating voltage (note 2)	V	8.0 to 12	V
Total power dissipation, $T_{mb} = 70^{\circ}\text{C}$	P_{tot}	max. 7.5	W
Output power, $f = 9.5\text{ GHz}$	P_{out}	min. 300	mW

This data must be read in conjunction with GENERAL SAFETY RECOMMENDATIONS – MICROWAVE SEMICONDUCTORS

MECHANICAL DATA

Dimensions in mm

Conforms to SOD-31

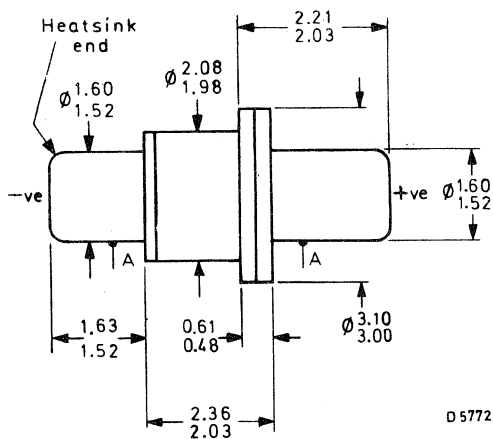

D 5772

A = concentricity tolerance = ± 0.13

Devices may be selected to suit customers' specific requirements.

RATINGS

Limiting values in accordance with the Absolute Maximum System (IEC134)

Storage temperature range	T_{stg}		-55 to +150	°C
Mounting base temperature range	T_{mb}		-40 to +70	°C
Operating voltage (note 1)	V	max.	12	V
Operating voltage for less than 1 ms	V	max.	14	V
Total power dissipation, $T_{mb} = 70\text{ °C}$	P_{tot}	max.	7.5	W

CHARACTERISTICS ($T_{amb} = 25\text{ °C}$)

		min.	typ.	max.	
Bias current (notes 1 and 2)	I_{dc}	—	650	950	mA
Threshold current		—	—	1.2	A
Operating frequency (note 3)	f	8.0	9.5	12	GHz
Output power (note 2)	P_{out}	300	325	—	mW

Notes

1. Bias must be applied in such a way that the mounting base (heatsink end) of the device is **always** negative. Reversing the polarity may cause permanent damage. Care should be taken to protect the device from transients.
2. Each device is measured for maximum output power at 9.5 GHz in a coaxial test cavity. The bias is optimized for this maximum within the V max. and P_{tot} max. ratings. The operating voltage and corresponding current are quoted for this condition on a test record supplied with each device.
3. The frequency is governed by the choice of cavity to which the device is coupled.
4. The heatsink end of the device should be held in a collect or equivalent clamping system to ensure maximum thermal resistance in the path to the mounting base. This in turn must be coupled to an adequate heatsink. Alternatively, direct soldering, using a low melting point solder, or an electrically conductive single loaded epoxy, such as Epotek H40, may be used.
5. The power supply should be low impedance, voltage regulated and capable of supplying approximately 1.5 times the normal current, to initiate oscillation.

GUNN EFFECT DEVICE

Gallium arsenide bulk effect device employing the Gunn effect to produce c.w. oscillations at microwave frequencies. Each device is encapsulated in a standard microwave package and conforms to the environmental requirements of BS9300 where applicable.

QUICK REFERENCE DATA

Operating frequency range	f		8.0 to 12	GHz
Operating voltage	V	typ.	8.0	V
Total power dissipation, $T_{mb} = 70\text{ }^{\circ}\text{C}$	P_{tot}	max.	2.5	W
Output power, $f = 9.5\text{ GHz}$	P_{out}	typ.	50	mW

This data must be read in conjunction with GENERAL SAFETY RECOMMENDATIONS – MICROWAVE SEMICONDUCTORS

MECHANICAL DATA

Dimensions in mm

Conforms to SOD-31

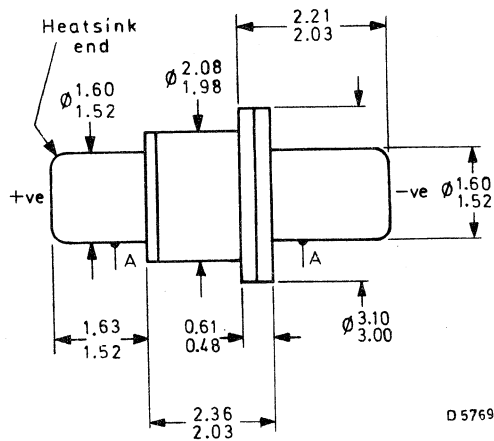

D 5769

A = concentricity tolerance = ± 0.13

Devices may be selected to suit customers' specific requirements.

RATINGS

Limiting values in accordance with the Absolute Maximum System (IEC134)

Storage temperature range	T_{stg}		-55 to +150	°C
Mounting base temperature range	T_{mb}		-40 to +70	°C
Operating voltage (note 1)	V	max.	10	V
Operating voltage for less than 1 ms	V	max.	12	V
Total power dissipation, $T_{mb} = 70\text{ °C}$	P_{tot}	max.	2.5	W

CHARACTERISTICS ($T_{amb} = 25\text{ °C}$)

		min.	typ.	max.	
Bias current, $V = 9.5\text{ V}$	I_{dc}	—	210	265	mA
Operating frequency (note 2)	f	8.0	—	12	GHz
Output power (note 3)	P_{out}	40	50	—	mW

Notes

1. The heatsink end is positive. Bias must be applied in such a way that the mounting base (heatsink end) of the device is always positive. Reversal of the polarity will cause permanent damage. Care should be taken to protect the device from transients. An 11 V voltage regulator diode to shunt the power supply is recommended for this purpose.
2. The frequency is governed by the choice of cavity to which the device is coupled.
3. The output power is normally measured in a coaxial cavity at approximately centre-band frequency. The bias may be optimized to give maximum output power within the limits of V max. and P_{tot} max.
4. The heatsink end of the device should be held in a collet or similar clamping system to ensure minimum thermal resistance in the path to the mounting base. This in turn must be coupled to an adequate heatsink. Alternatively, direct soldering, using a low melting point solder, or an electrically conductive single loaded epoxy, such as Epotek H40, may be used.
5. The power supply should be low impedance, voltage regulated and be capable of supplying 1.5 times the normal current, to initiate oscillation.

GUNN EFFECT DEVICES

Gallium arsenide bulk effect devices employing the Gunn effect to produce c.w. oscillations at microwave frequencies. They are encapsulated in metal-ceramic packages suitable for mounting in various types of cavity. The device will oscillate in Q-band (Ka-band), the actual frequency being determined by the type of cavity.

QUICK REFERENCE DATA

Operating frequency range		f	30 to 38	GH:
Operating voltage		V	typ. 3.5	V
Operating current		I	typ. 0.8	A
Output power, f = 34 GHz	CXY24A	P _{out}	min. 25	mW
	CXY24B		50	mW

This data must be read in conjunction with GENERAL SAFETY RECOMMENDATIONS — MICROWAVE SEMICONDUCTORS

MECHANICAL DATA

Conforms to MO-75

Dimensions in mm

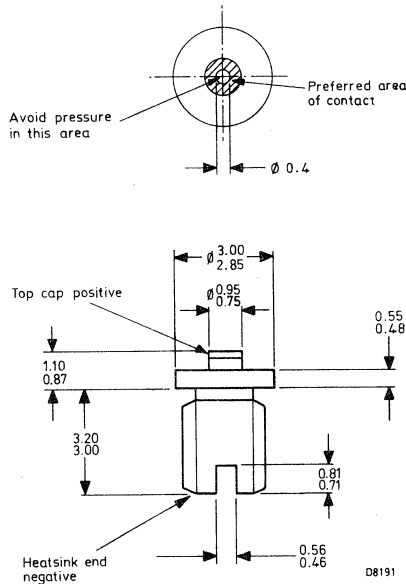

Devices may be selected to suit customers' specific requirements.

RATINGS

Limiting values in accordance with the Absolute Maximum System (IEC134)

Storage temperature range	T_{stg}		-55 to +150	°C
Operational stud temperature (note 1)	T_{stud}	max.	70	°C
Transient supply voltage (note 2)		max.	6.0	V
Continuous supply voltage	V	max.	note 3	
Input power (note 3)	P_{in}	max.	4.0	W

CHARACTERISTICS ($T_{amb} = 25\text{ °C}$)

		min.	typ.	max.	
Operating voltage (notes 2 and 3)	V	—	3.5	5.0	V
Operating current (note 4)	I_{dc}	—	0.8	1.1	A
Threshold current		—	—	1.6	A
Operating frequency (note 5)	f	30	34	38	GHz
Output power (note 6)	CXY24A	25	30	—	mW
	CXY24B	50	60	—	mW

Notes

1. Good thermal conductivity is essential between the heatsink end of the device and the cavity.
2. Bias must be applied in such a way that the heatsink end of the device is always negative. Reversing the polarity may cause permanent damage. Care should be taken to protect the device against transient voltages.
3. Each device is supplied with a maximum supply voltage recommendation for continuous operation, within the limits of operating voltage and input power specified above.
4. The power supply should be low impedance, voltage regulated and capable of supplying current in excess of the threshold current.
5. The frequency is governed by the choice of cavity to which the device is coupled.
6. Output power is normally measured in a waveguide cavity at a frequency of 34 GHz, at a voltage not exceeding the maximum recommended supply voltage (note 2) and at a stud temperature of 25 °C.

MIXER AND DETECTOR DIODES

C





C

MICROWAVE MIXER/DETECTOR DIODES

Silicon Schottky barrier beam-lead diodes for use as low noise mixer or low level detector in hybrid integrated circuits.

The production process ensures exceptionally uniform characteristics and very low parasitic capacitance.

Matched pairs are available as 2-BAS22, 2-BAS23, 2-BAS24 and 2-BAS25. These are produced as adjacent pairs on the wafer, to ensure very accurate matching.

QUICK REFERENCE DATA

Frequency range	f		1 to 18	GHz
Noise figure	N_o	typ.	5.7	dB
Tangential sensitivity	S_{ts}	typ.	-55	dBm

This data must be read in conjunction with GENERAL SAFETY RECOMMENDATIONS –
MICROWAVE SEMICONDUCTORS

MECHANICAL DATA

Dimensions in μm

Fig.1

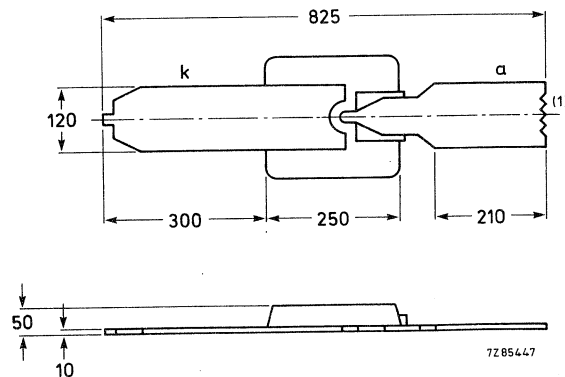

- (1) Identification
- one notch = BAS22
 - two notches = BAS23
 - three notches = BAS24
 - four notches = BAS25

The maximum lead pulling forces should not exceed 20 mN

RATINGS

Limiting values in accordance with the Absolute Maximum System (IEC 134)

Continuous reverse voltage	BAS22	V_R	max.	3.5	V
	BAS23 to 25	V_R	max.	4.0	V
Non-repetitive peak forward current ($t \leq 1s$)		I_{FSM}	max.	150	mA
Storage temperature		T_{stg}		-65 to +150	°C
Junction temperature		T_j	max.	150	°C
Soldering temperature ($t_{sld} < 10 s$)		T_{sld}	max.	230	°C

CHARACTERISTICS

$T_{amb} = 25 \text{ }^\circ\text{C}$

Reverse breakdown voltage

$I_R = 10 \text{ } \mu\text{A}$

Forward voltage

$I_F = 1 \text{ mA}$

→ Total capacitance (note 1)

$V_R = 0.5 \text{ V}; f = 1 \text{ MHz}$

Parasitic capacitance

Series resistance

Lead inductance

			BAS22	BAS23	BAS24	BAS25	
Reverse breakdown voltage	$V_{(BR)R} >$		3.5	4.0	4.0	4.0	V
Forward voltage	$V_F <$		0.55	0.50	0.50	0.50	V
Total capacitance (note 1)	$C_{tot} >$		0.08	0.12	0.16	0.24	pF
	$C_{tot} <$		0.12	0.16	0.20	0.32	pF
Parasitic capacitance	C_p	typ.	0.03	0.04	0.05	0.07	pF
Series resistance	r_s	typ.	12	8	6	4.5	Ω
Lead inductance	L_s	typ.	0.1	0.1	0.1	0.1	nH
Frequency range	f		1 to 18				GHz
Noise figure (note 2)	N_O	typ.	5.7				dB
Intermediate frequency impedance	Z_{if}		200 to 400				Ω
Tangential sensitivity (note 3)	S_{ts}	typ.	-55				dBm

Notes

1. The two devices of a matched pair have a capacitance difference $\leq 0.01 \text{ pF}$.
2. S.S.B. operation, measured at 9.375 GHz, local oscillator power 1 mW including $N_{if} = 1.5 \text{ dB}$, $f_{if} = 30 \text{ MHz}$.
3. Measured at 9.375 GHz with 2 MHz video bandwidth and 50 μA forward bias current.

HANDLING INSTRUCTIONS

The beam lead diodes require careful and considerate handling during inspection, testing, and assembly so that they will not be mechanically or electrically damaged. The diodes are very small. Magnification is necessary to view them inside the shipping container.

The diodes are shipped in a flat, plastic container. The inside bottom surface of the container is coated with a thin layer of silicone to which the diodes adhere. They are covered with anti-static silk. A vacuum pickup is recommended for removing them from the container. This should be done under 20 x magnification for accurate positioning of the tip on the die.

A beam lead diode can be destroyed electrically by a static discharge through the diode. Hence, they must be handled so that static discharges cannot occur.

If a vacuum pickup is not used, it is recommended that a wooden toothpick or sharpened Q-tip dipped in alcohol be used as a handling probe. A diode will adhere to the end of the wooden probe without danger of mechanically or electrically damaging the diode. It can then be placed where required.

BONDING RECOMMENDATIONS

Beam lead devices are silicon chips with coplanar plated gold tabs that extend parallel to the top surface of the chip. The leads are mounted by thermocompression bonding to the substrate metallization. The bonding is accomplished by placing the device face down with the tabs resting flat on the pad area and using heated wedge (and/or substrate) or parallel-gap (spot-welding) techniques.

The heated wedge may be continuously heated, as in most standard equipment, or it may be pulse resistance heated where a high current, short duration pulse is used to raise the wedge to the required temperature. In the spot-welding operation, current is passed through the substrate metallization and the device lead. Most of the heat is generated at the interface between the two, where the bond is formed.

The major advantage of pulse heating is that it generates only localized heating in the vicinity of the bond. The electrodes (or wedge) can be placed on the device lead while the bond area is cold, and maintain a constant force through the heating and cooling cycle.

OPERATING NOTES

Care must be taken when making measurements that the precautions described in the operating notes are observed and that test equipment does not introduce transients.

1. The diode has a low junction capacitance and may be damaged by transients of very short duration. It is therefore recommended that soldering irons are isolated from the mains supply when making soldered connections to the diode.
2. Precautions similar to those required for CMOS devices are necessary namely:
 - (a) Earthed wrist straps should be worn.
 - (b) Table tops or other working surfaces should be conductive and earthed.
 - (c) Anti-static clothing should be worn.
 - (d) To prevent the development of damaging transient voltages, the device should not be inserted or removed from the user's circuit with the d.c. power applied.

BAS22; 2-BAS22

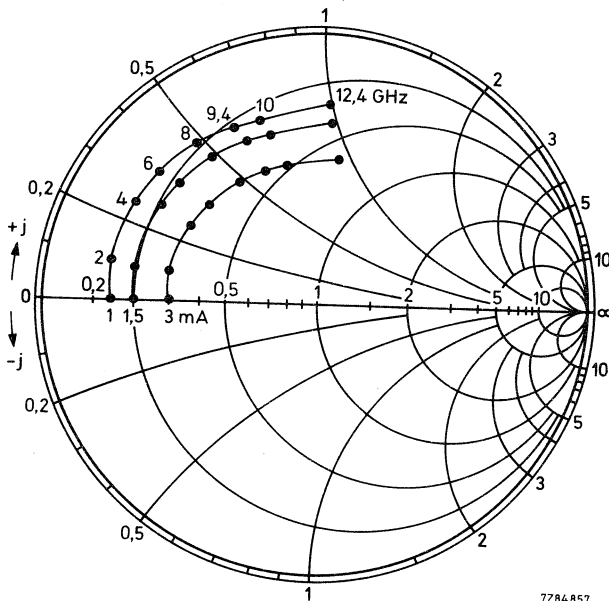

Fig.2 Admittance characteristics.
Typical values; self bias

7284 857

BAS23; 2-BAS23

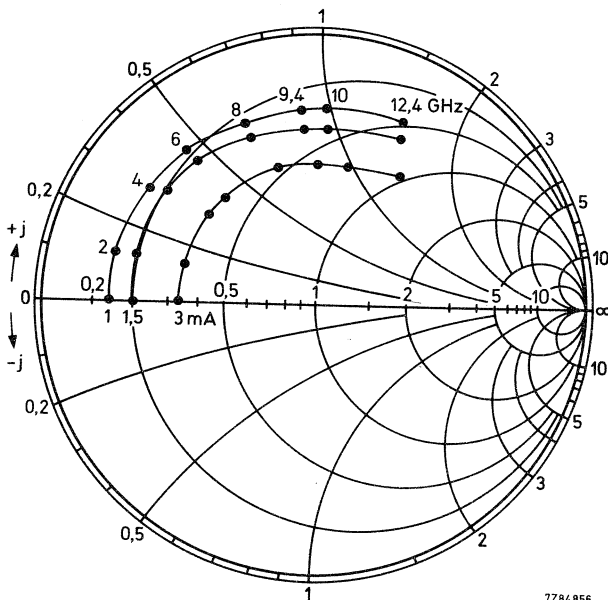

Fig.3 Admittance characteristics.
Typical values; self bias.

7284 856

BAS24; 2-BAS24

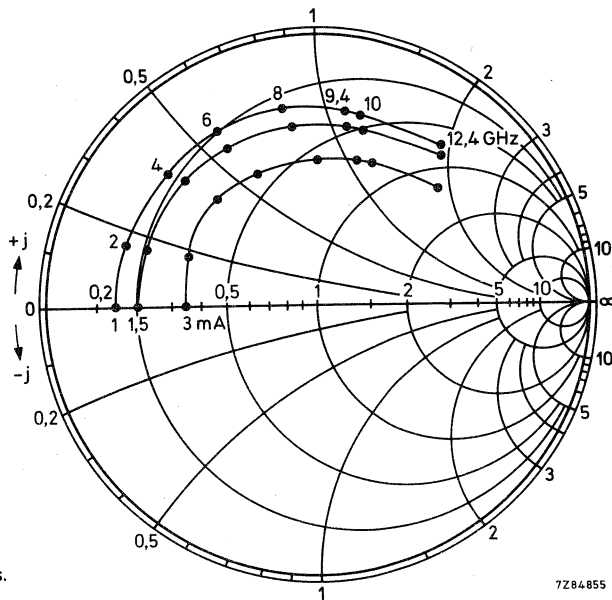

Fig.4 Admittance characteristics.
Typical values; self bias.

7Z84855

BAS25; 2-BAS25

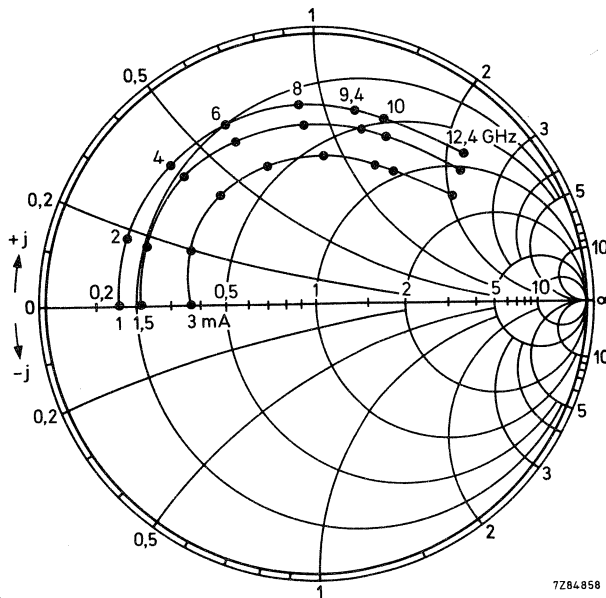

Fig.5 Admittance characteristics.
Typical values; self bias.

7Z84858

X-BAND MIXER/DETECTOR DIODE

Silicon Schottky barrier diode in DO-23 outline specially designed for use in Doppler radar systems and intruder alarms where low 1/f noise and high sensitivity are required. May be used for both mixer and detector applications. This device is a direct replacement for the BAV46 and has an all-bonded structure capable of withstanding higher shock levels and wide temperature excursions during operation and storage.

QUICK REFERENCE DATA

Mixer mode

Voltage output for -90 dBm input power at X-band	typ.	40	μV
1/f noise in the bandwidth 1 Hz to 1 kHz from carrier	typ.	1.0	μV

Detector mode

Tangential sensitivity in bandwidth 0 to 2 MHz	typ.	-55	dBm
--	------	-----	-----

This data must be read in conjunction with GENERAL SAFETY RECOMMENDATIONS - MICROWAVE SEMICONDUCTORS

MECHANICAL DATA

Conforms to SOD-48

Compatible with JEDEC DO-23

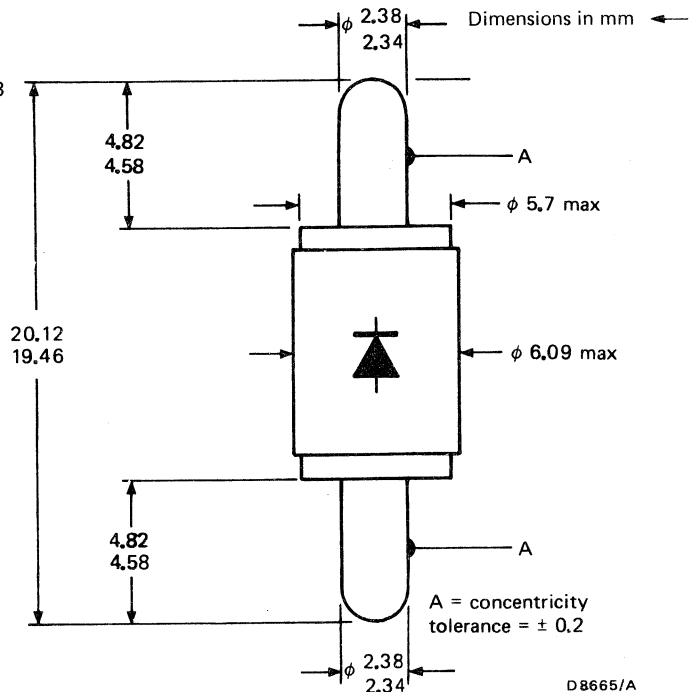

Terminal identification: diode symbol indicates polarity

Accessory: collet type 56321 (see page 4) converts BAS46 to JEDEC DO-22 outline.

RATINGS

Limiting values in accordance with the Absolute Maximum System (IEC 134)

Storage temperature range	T_{stg}	-55 to +125	°C
Ambient temperature range for operation	T_{amb}	-55 to +125	°C
Reverse voltage	V_R	max. 2	V
Forward current	I_F	max. 10	mA

CHARACTERISTICS ($T_{amb} = 25\text{ °C}$)

Forward voltage at $I_F = 1\text{ mA}$	V_F	typ. 0.5	V
Reverse current at $V_R = 2\text{ V}$	I_R	max. 2	μA

Mixer mode

Voltage output at X-band (notes 1 and 2)	V_O	min. 15	μV
	V_O	typ. 40	μV
$1/f$ noise (note 3)	N_f	typ. 1.0	μV
	N_f	max. 2.0	μV

Detector mode

Tangential sensitivity (note 4)	S_{ts}	min. -52	dBm
	S_{ts}	typ. -55	dBm
Video impedance (note 5)	Z_v	typ. 850	Ω

Notes

1. Mixer operated with d.c. bias of 35 μA and r.f. bias of -18 dBm, giving a total bias of 42 μA .
2. Measurement made using CL8960 doppler radar module, output power 10 mW (typ.). The input power to the mixer of -90 dBm is a signal 100 dB down on the output power from a typical CL8960 with signal + noise at 18 dB (min.)
noise

A return signal, 100 dB down on radiated power, is equivalent to that achieved from a man target of radar cross-section 1.0 m² at a range of 15 m when operating the CL8960 with a 5 dB antenna.

3. Other encapsulations may be made available on request.

Measurement circuit:

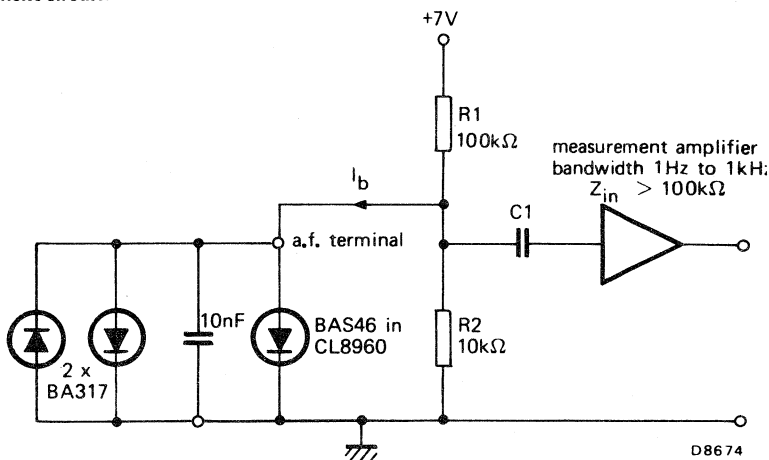

- N.B. a) The current I_b should be approximately $35 \mu\text{A}$ with the Gunn device disconnected and approximately $42 \mu\text{A}$ with the Gunn device operational and the antenna operating into free space, using the mounting suggested in the CL8960 data.
- b) The coupling capacitor C_1 should have a small impedance compared with Z_{in} . See measurement circuit above.
- Noise measured in the bandwidth 1 Hz to 1 kHz from carrier with a d.c. bias of $50 \mu\text{A}$.
 - Bandwidth 0 to 2 MHz and a forward bias of $50 \mu\text{A}$.
 - Measured with a forward bias of $50 \mu\text{A}$.

OPERATING NOTES

Care must be taken when making measurements that the precautions described in the operating notes are observed and that test equipment does not introduce transients.

- The diode has a low junction capacitance and may be damaged by transients of very short duration. It is therefore recommended that soldering irons are isolated from the mains supply when making soldered connections to the diode.
- Precautions similar to those required for CMOS devices are necessary namely:
 - Earthed wrist straps should be worn.
 - Table tops or other working surfaces should be conductive and earthed.
 - Anti-static clothing should be worn.
 - To prevent the development of damaging transient voltages, the device should not be inserted or removed from the user's circuit with the d.c. power applied.
- It is recommended that the user incorporates a diode protection circuit. A suitable circuit consists of two BA317 diodes connected in parallel but with one diode reversed, together with a parallel 10 nF capacitor. This circuit should be connected in close proximity to the diode terminals and has been found to afford a suitable degree of protection.
- A d.c. bias level of at least $30 \mu\text{A}$ must be maintained to ensure adequate mixer performance.

BAS46

COLLET 56321

Dimensions in mm

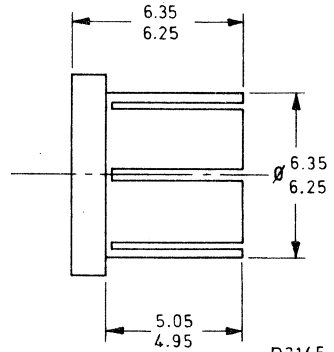
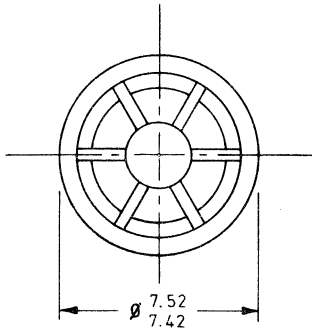

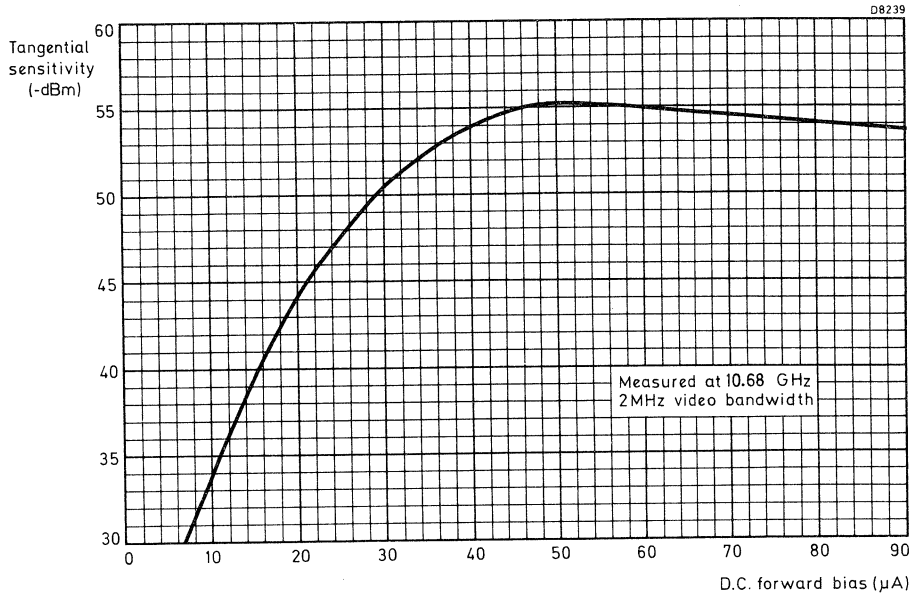

Typical tangential sensitivity as a function of d.c. forward bias.

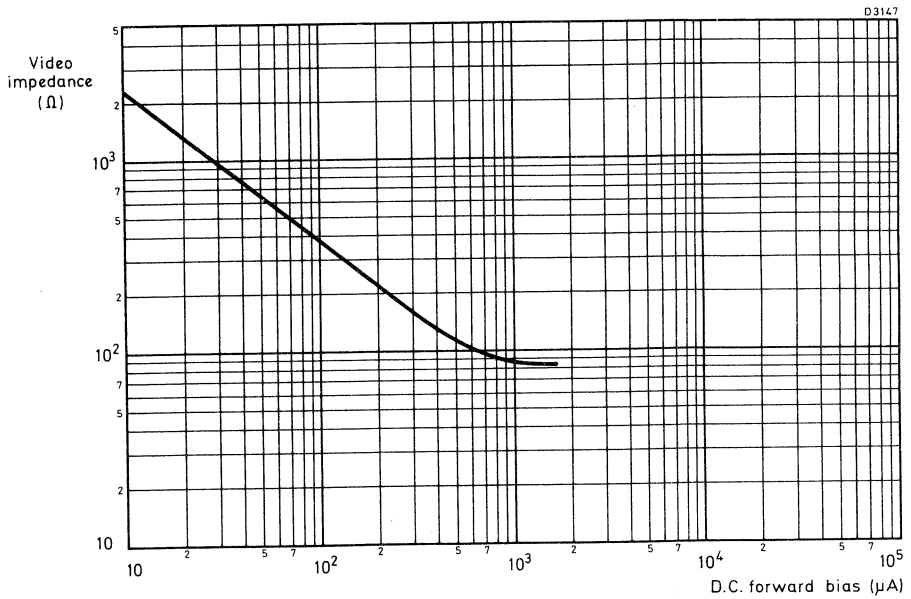

Typical video impedance as a function of d.c. forward bias

MICROWAVE MIXER/DETECTOR DIODE

Silicon Schottky barrier diode for use as a low level detector or as a low noise mixer at microwave frequencies. The diode is plastic encapsulated with ribbon leads suitable for mounting in stripline circuitry and conforms to the environmental requirements of BS9300 where applicable. Available as a matched pair 2/BAT10 M.

QUICK REFERENCE DATA

Frequency range		1 to 12	GHz
Mixer:			
Noise figure in X-band	typ.	7.0	dB
Detector:			
Tangential sensitivity in X-band with 100 μ A bias	typ.	-50	dBm
Current sensitivity in X-band with 50 μ A bias	typ	5.0	μ A/ μ W

This data must be read in conjunction with GENERAL SAFETY RECOMMENDATIONS – MICROWAVE SEMICONDUCTORS

MECHANICAL DATA

Dimensions in mm ←

Conforms to MO-28

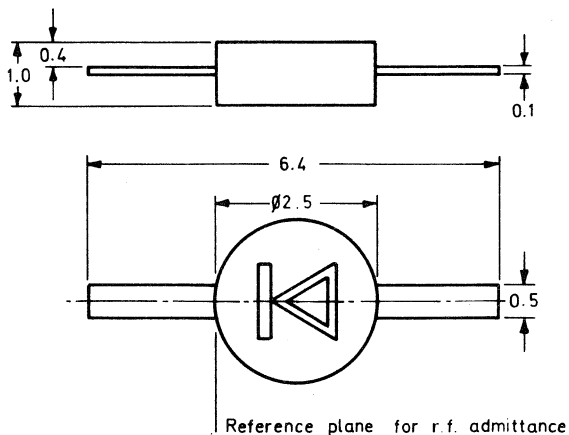

D3108

RATINGS

Limiting values in accordance with the Absolute Maximum System (IEC134)

Storage temperature range		-55 to +150	°C
Ambient temperature range		-55 to +150	°C
Peak pulsed r.f. input power at 9.375 GHz, 0.5 μ s pulse length	max.	1.0	W
Burn out (multiple r.f. spike, $\Delta N_O = 1$ dB)	max.	20	nJ
		0.2	erg

CHARACTERISTICS ($T_{amb} = 25$ °C)

Mixer		typ.	max.	
Noise figure (note 1)	N_O	7.0	7.5	dB
Voltage standing wave ratio (note 2)	v.s.w.r.	—	2:1	
Intermediate frequency impedance (note 3)	Z_{if}	—	500	Ω

Detector

Tangential sensitivity (note 4)	S_{ts}	-50	—	dBm
Current sensitivity (note 5)	S_i	5.0	—	μ A/ μ W
Voltage standing wave ratio (note 6)	v.s.w.r.	—	5:1	
Video impedance (note 7)	Z_v	600	—	Ω
Noise	1/f	12	17	dB

Notes

1. Measured in a 50 Ω test mount at $f = 9.375$ GHz, rectified current = 2.0 mA, load resistance = 20 Ω , i.f. = 45 MHz and i.f. noise figure = 1.5 dB. BS9300.
2. Measured with respect to 50 Ω at $f = 9.375$ GHz, rectified current = 2.0 mA and load resistance = 10 Ω . BS9300.
3. Measured in a 50 Ω test mount at $f = 9.375$ GHz, rectified current = 2.0 mA, load resistance = 20 Ω and i.f. = 45 MHz. BS9300.
4. Measured at $f = 9.375$ GHz with 2.0 MHz bandwidth and 100 μ A bias.
5. Measured at $f = 9.375$ GHz at an input power of 1.0 μ W and 50 μ A bias.
6. Measured with respect to 50 Ω at $f = 9.375$ GHz, 100 μ A bias and c.w. input less than 2.0 μ W. BS9300.
7. D.C. measurement with 1.0 mV max. and 50 μ A bias.
8. Other encapsulations may be made available on request.
9. Matched pairs of diodes are available to customer specifications.

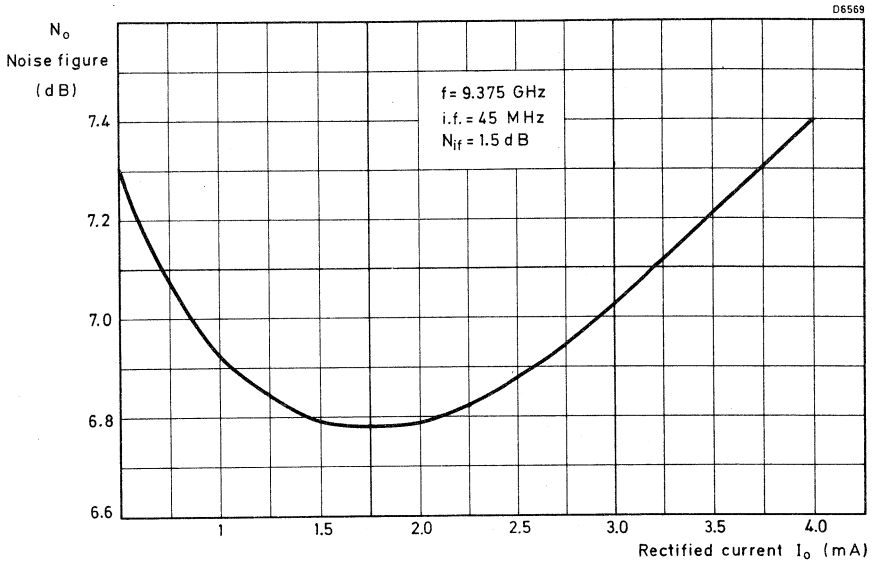

Typical noise figure as a function of rectified current (as a mixer)

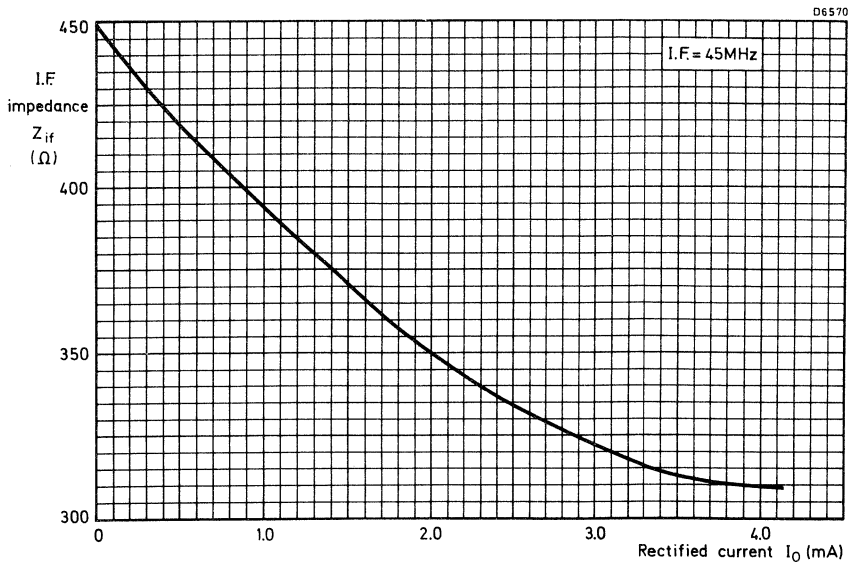

Typical i.f. impedance as a function of rectified current (as a mixer)

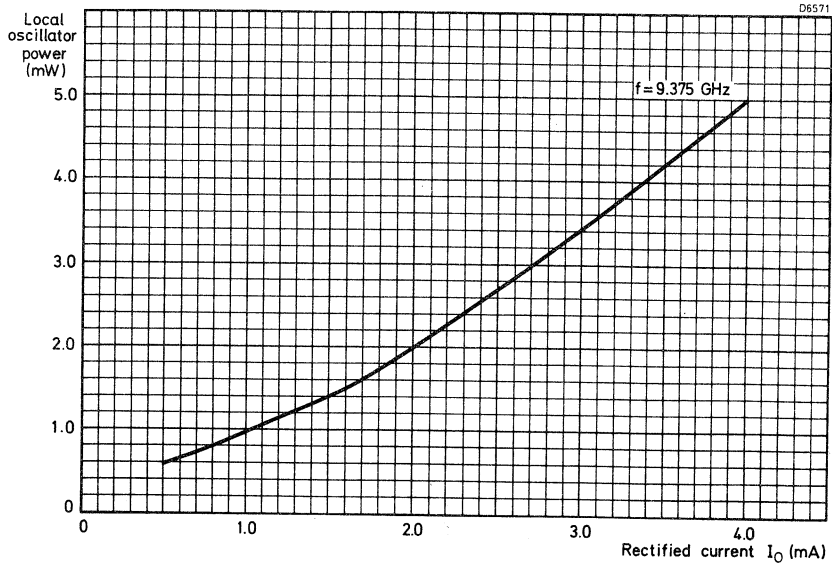

Typical local oscillator power as a function of rectified current (as a mixer)

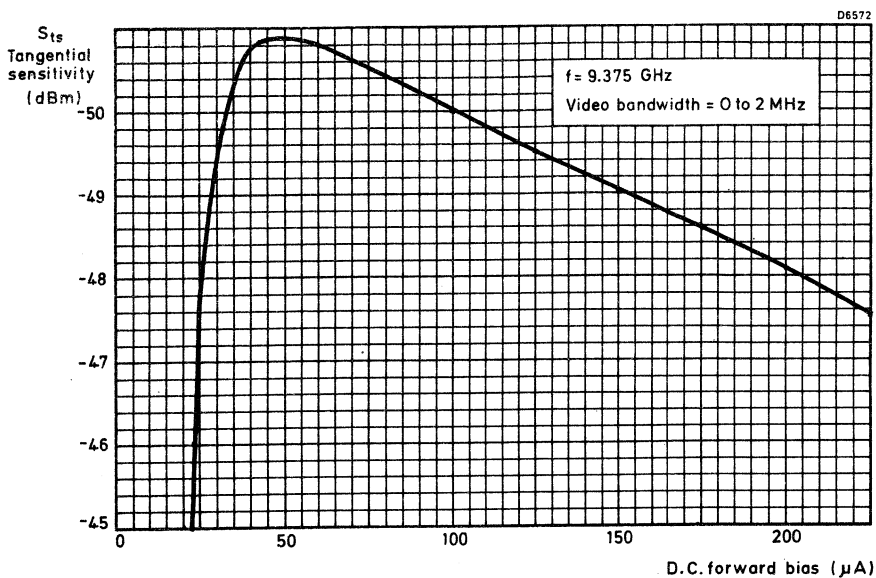

Typical tangential sensitivity as a function of d.c. forward bias current (as a detector)

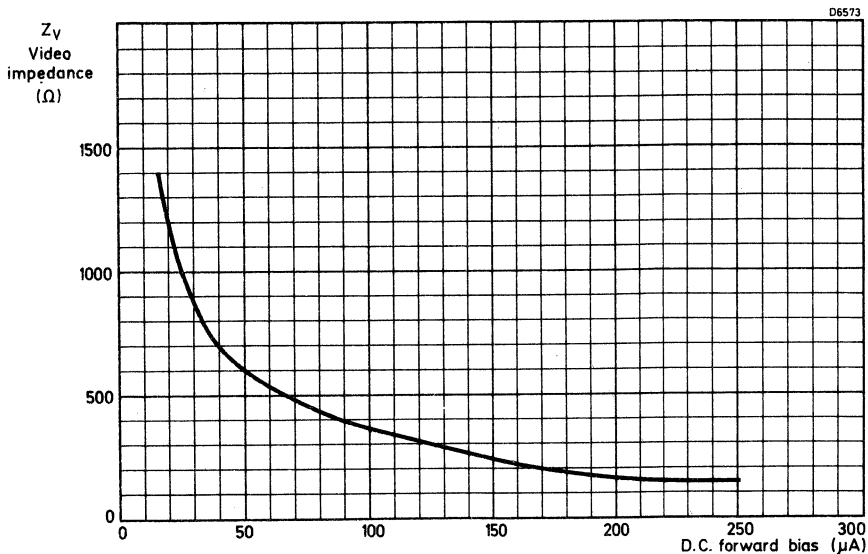

Typical video impedance as a function of d.c. forward bias current (as a detector)

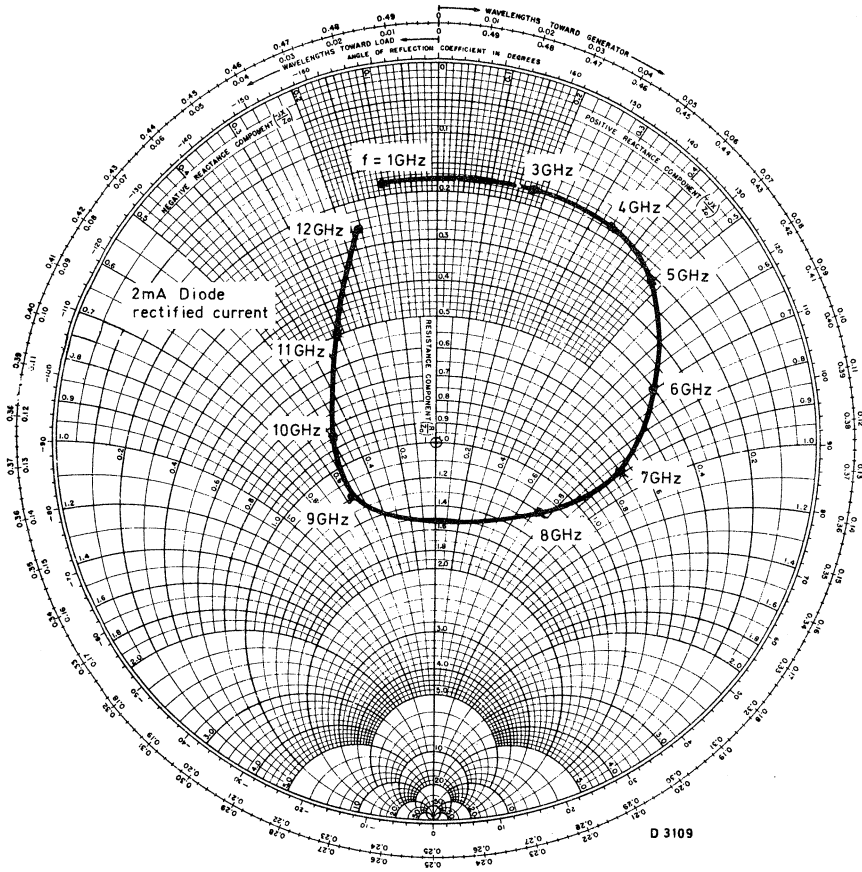

Typical admittance as a function of frequency

MICROWAVE MIXER DIODE

Silicon Schottky barrier low noise mixer diode mounted in a L.I.D. type envelope. Primarily intended for hybrid integrated circuit applications in X-band. It conforms to the environmental requirements of BS9300 where applicable. Available as a matched pair 2/BAT11M.

QUICK REFERENCE DATA

Frequency range		up to 12	GHz
Noise figure in X-band	typ.	6.5	dB

This data must be read in conjunction with GENERAL SAFETY RECOMMENDATIONS – MICROWAVE SEMICONDUCTORS

MECHANICAL DATA

Dimensions in mm

Conforms to MO-27

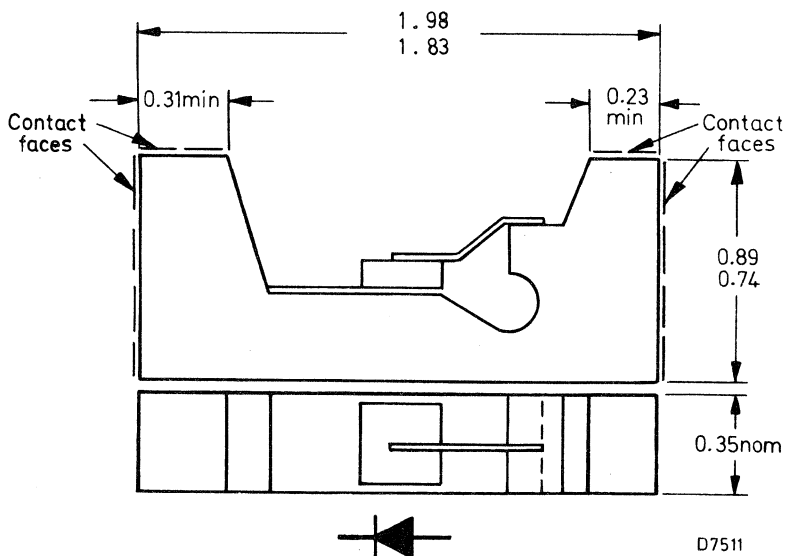

D7511

Contact faces are gold plated, 5 μ m over 1.27 μ m of nickel.

RATINGS

Limiting values in accordance with the Absolute Maximum System (IEC134)

Storage temperature range	T_{stg}	-55 to +150	°C
Ambient temperature range	T_{amb}	-55 to +150	°C
Burn-out (r.f. spike)		max. 20	nJ
		0.2	erg
Burn-out (multiple d.c. spike)		max. 30	nJ

CHARACTERISTICS ($T_{amb} = 25\text{ }^{\circ}\text{C}$)

		min.	typ.	max.	
→ Dynamic					
Noise figure (note 1)	N_o	-	6.5	7.0	dB
Voltage standing wave ratio	v.s.w.r.	-	-	2:1	
Intermediate frequency impedance (note 3)	Z_{if}	280	320	380	Ω
Operating frequency range	f	-	-	12	GHz

Notes

1. Measured at $9.375\text{ GHz} \pm 0.1\text{ GHz}$, 1.5 mA rectified current, $R_L = 15\ \Omega$. N_o includes $N_{if} = 1.5\text{ dB}$ with 45 MHz intermediate frequency. BS9300, method 1406.
2. Measured at $9.375\text{ GHz} \pm 0.1\text{ GHz}$, 1.5 mA rectified current, $R_L = 15\ \Omega$. BS9300, method 1409.
3. Measured at $9.375\text{ GHz} \pm 0.1\text{ GHz}$, 1.5 mA rectified current, $R_L = 15\ \Omega$, intermediate frequency 45 MHz. BS9300 method 1405.
4. Maximum out of balance for a matched pair:
 - a) 0.1 mA rectified current.
 - b) R.F. admittance 1.5:1 with other diode normalized to $50\ \Omega$.
5. The diode may be mounted on microstrip, using conventional thermocompression or micro-gap bonding techniques. Alternatively, the application of a single loaded epoxy, such as Epotek H40, may be used, followed by polymerisation at $150\text{ }^{\circ}\text{C}$ for 15 minutes. The force applied to the L.I.D. must not exceed 147 mN (15 gf).

6. Devices may be specially selected with the r.f. impedance measured at a customer's specific frequency in the range 8.4 to 12 GHz.

7. Other encapsulations may be made available on request.
8. The diode is available, on request, with a protective coating of gel around the mechanically sensitive part of the device.

D5855

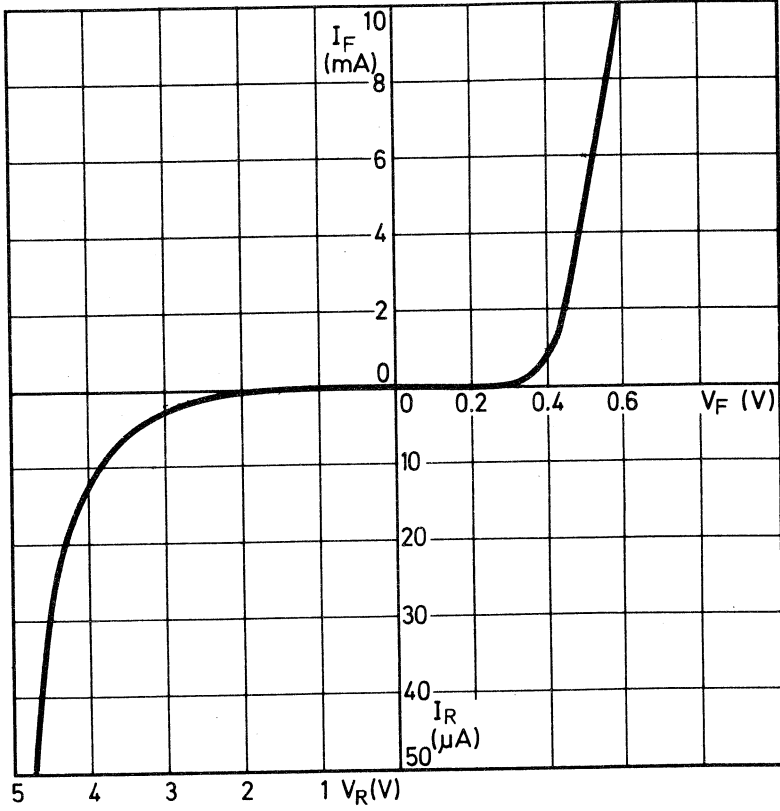

Typical d.c. characteristic

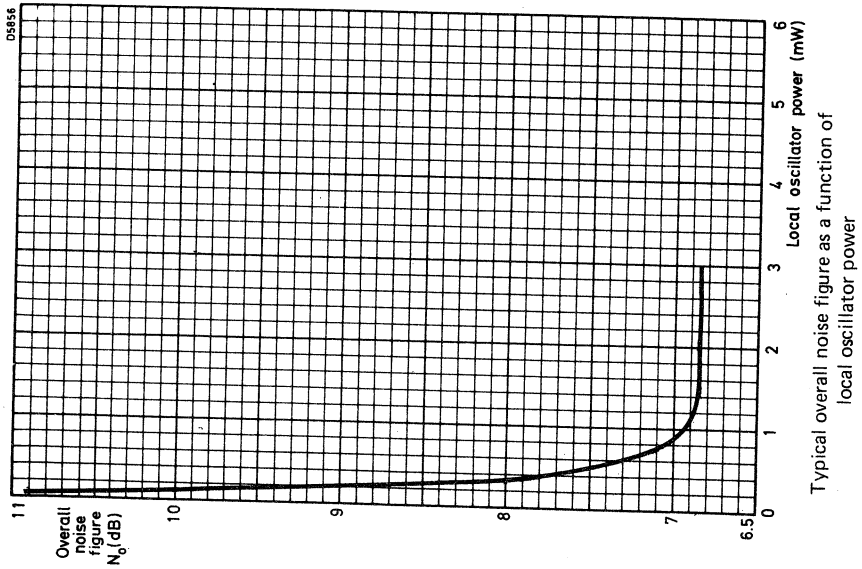
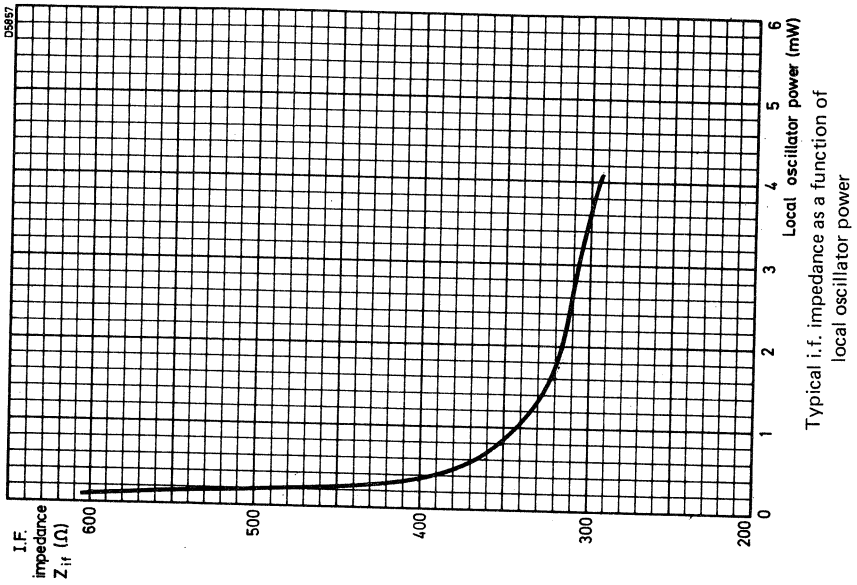

MICROWAVE MIXER DIODE

Subminiature silicon Schottky barrier mixer diode for use at Q-band (Ka-band) frequencies. Where applicable, this device conforms to the environmental requirements of BS9300. It can be supplied to NATO stock No. 5691-99-038-0540.

QUICK REFERENCE DATA

Frequency range		26 to 40	GHz
Noise figure	typ.	8.5	dB

This data must be read in conjunction with GENERAL SAFETY RECOMMENDATIONS – MICROWAVE SEMICONDUCTORS

MECHANICAL DATA

Dimensions in mm

Conforms to SOD-42

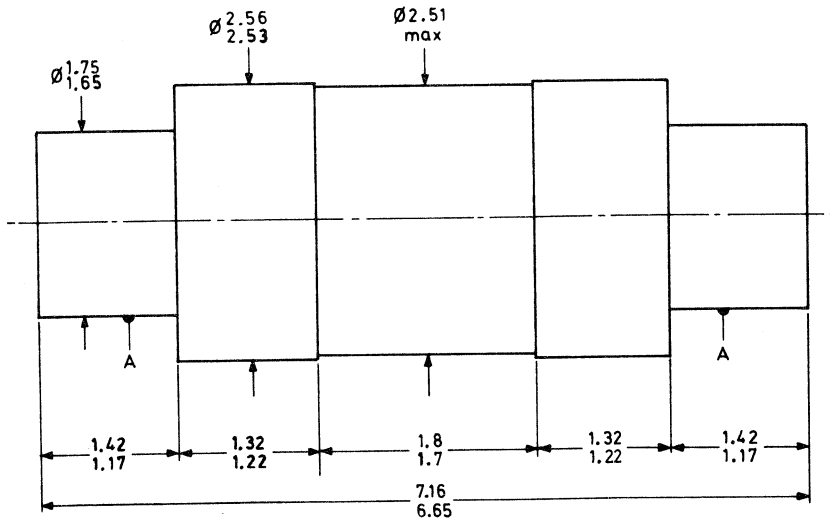

D2527a

AA = concentricity tolerance = ± 0.15

The cathode (positive) is marked red.

The cathode indicates the electrode which becomes positive in an a.c. rectifier circuit.

BAT 38

RATINGS

Limiting values in accordance with the Absolute Maximum System (IEC134)

Burn-out

R.F. spike	max.	0.04	erg
Peak pulse power ($t_p = 0.2 \mu s$)	max.	0.5	W

The devices are 100% burn-out screened to the above specifications at 34 GHz.

Temperature

Storage temperature	T_{stg}	-55 to +100	°C
Ambient temperature	T_{amb}	-55 to +100	°C

→ CHARACTERISTICS $T_{amb} = 25 \text{ }^\circ\text{C}$

Reverse current ($V_R = 0.5 \text{ V}$)	I_R	max.	2.0	μA
Forward current ($V_F = 0.5 \text{ V}$)	I_F	min.	2.0	mA
Overall noise figure f = 34.86 GHz, rectified current = 0.5 mA N_O includes N_{if} of 1.5 dB. BS9300, method 1406	N_O	typ. max.	8.5 10	dB dB
Conversion loss	L_c	typ.	5.5	dB
Noise temperature ratio I.F. = 45 MHz	N_r		1.6:1	
→ Voltage standing wave ratio* f = 34.86 GHz, rectified current = 0.5 mA $R_L = 15 \Omega$. BS9300, method 1409	v.s.w.r.	typ. max.	1.4:1 2.0:1	
Intermediate frequency impedance f = 34.86 GHz, rectified current = 0.5 mA $R_L = 15 \Omega$, i.f. = 45 MHz. BS9300, method 1405	Z_{if}	typ.	900	Ω
Operating frequency range	f		700 to 1100 26 to 40	Ω GHz

MATCHED PAIRS

The diodes can be supplied in matched pairs under the type number 2/BAT38M. The diodes are matched to $\pm 10\%$ on rectified current and within 150Ω i.f. impedance.

* Standard test holder.

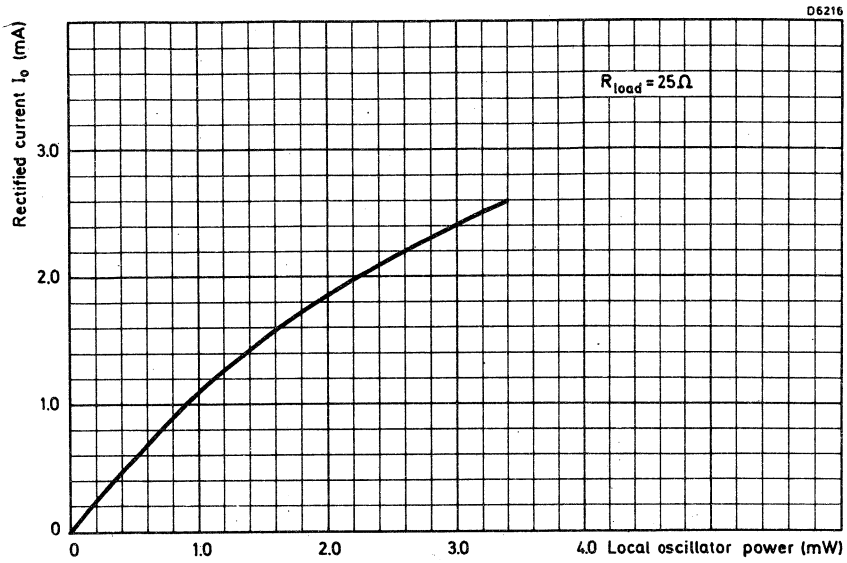

Fig.2 Typical rectified current as a function of local oscillator power at 34.86 GHz

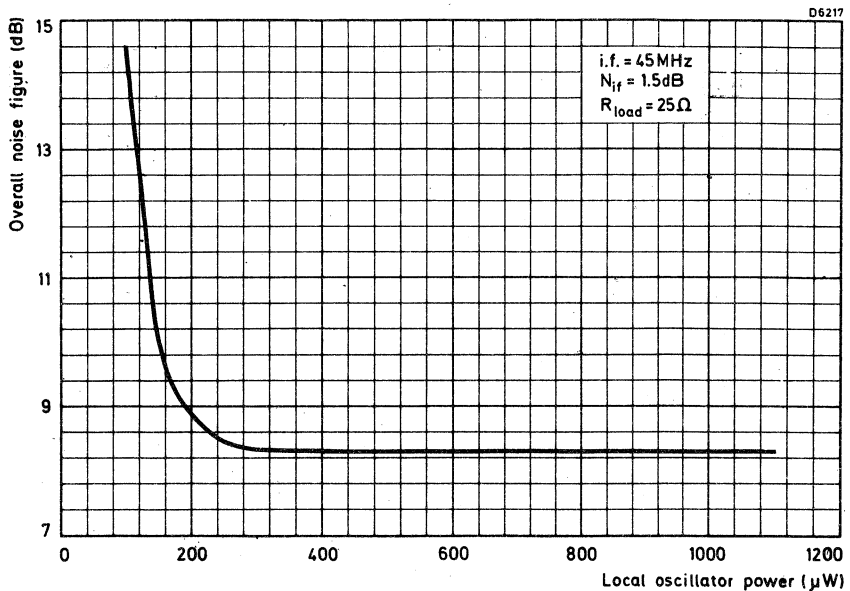

Fig.3 Typical overall noise figure as a function of local oscillator power at 34.86 GHz

MICROWAVE MIXER DIODE

Subminiature silicon reversible Schottky barrier diode primarily intended for low noise mixer applications in X-band. It is intended as a retrofit for AAY39 and CV7762. Available as a matched pair as 2/BAT39M. Can be supplied to NATO stock No. 5961-99-037-5207.

QUICK REFERENCE DATA

Operating frequency range		1.0 to 18	GHz
Noise figure at X-band	typ.	6.0	dB

This data must be read in conjunction with GENERAL SAFETY RECOMMENDATIONS – MICROWAVE SEMICONDUCTORS

MECHANICAL DATA

Dimensions in mm

Conforms to SOD-42

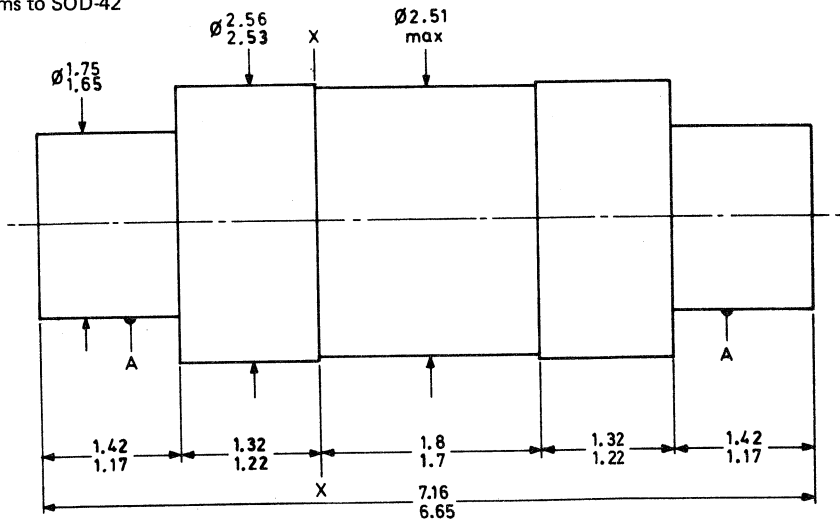

XX = reference plane

All dimensions in mm

D2527a

AA = concentricity tolerance = ± 0.15

Terminal identification:

The BAT39 is colour coded as follows:

That is: the positive end (cathode) is marked red and the negative end (anode) is marked blue.

The positive end indicates the electrode which becomes positive in an a.c. rectifier circuit.

ACCESSORIES

WG16 holders to fit these diodes are available in the U.K. from Marconi Instruments Ltd., (Sanders Division), Gunnels Wood Road, Stevenage, Herts.

BAT39

RATINGS

Limiting values in accordance with the Absolute Maximum System (IEC134)

Temperature

Storage temperature range	T_{stg}	-55 to +100	°C
Ambient temperature range	T_{amb}	-55 to +100	°C

Burn-out ($f = 9.375$ GHz)

Multiple d.c. spike		max.	0.1	erg
Multiple r.f. spike (spike width at half peak power = $2 \mu s$)		max.	0.05	erg
Peak pulse power $f = 9.375$ GHz, $t_p = 1.0 \mu s$		max.	0.5	W

CHARACTERISTICS ($T_{amb} = 25$ °C)

		min.	typ.	max.	
Reverse current $V_R = 0.5$ V	I_R	—	—	2.0	μA
Forward current $V_F = 0.5$ V	I_F	—	7.0	—	mA
Overall noise figure $f = 9.375$ GHz, $R_L = 15 \Omega$, rectified current = 1.0 mA, N_O includes $N_{if} = 1.5$ dB. BS9300, method 1406	N_O	5.5	6.0	6.5	dB
Conversion loss	L_C	—	4.2	—	dB
Noise temperature ratio I.F. = 45 MHz. BS9300, method 1407	N_T	—	1.1:1	—	
→ Voltage standing wave ratio $f = 9.375$ GHz, $R_L = 15 \Omega$, rectified current = 1.0 mA. BS9300, method 1409 Measured in standard test holder	v.s.w.r.	—	1.4:1	2.0:1	
Intermediate frequency impedance $f = 9.375$ GHz, $R_L = 15 \Omega$, rectified current = 1.0 mA. BS9300, method 1405	Z_{if}	250	—	450	Ω
Operating frequency range	f	1.0	—	18	GHz

OPERATING NOTE

Optimum performance is obtained when the local oscillator drive is adjusted to give a diode rectified current of 1.0 mA and the load resistance is restricted to 100 Ω max.

NOTE

Matched pairs of diodes are available to customer specifications.

APPLICATION INFORMATION

Mixer performance at other than Test Radio Frequency

Measured overall noise figure

f = 16.5 GHz, N_{if} = 1.5 dB, i.f. = 45 MHz N_o typ. 7.0 dBf = 3.0 GHz, N_{if} = 1.5 dB, i.f. = 45 MHz N_o typ. 5.5 dB

f = 9.5 GHz, i.f. = 3.0 kHz

 N_o typ. 29 dB

Signal/flicker noise at 9.5 GHz

Measured at 2.0 kHz from carrier in a 70 Hz bandwidth

typ. 131 dB

Detector performance

Tangential sensitivity at 9.375 GHz,

1 kHz to 1 MHz video bandwidth,

 I_F (bias) = 50 μ A (BS9300/1411) S_{ts} typ. -52 dBm

A.C. video impedance

 I_F (bias) = 50 μ A (BS9300/1403) Z_r typ. 800 Ω

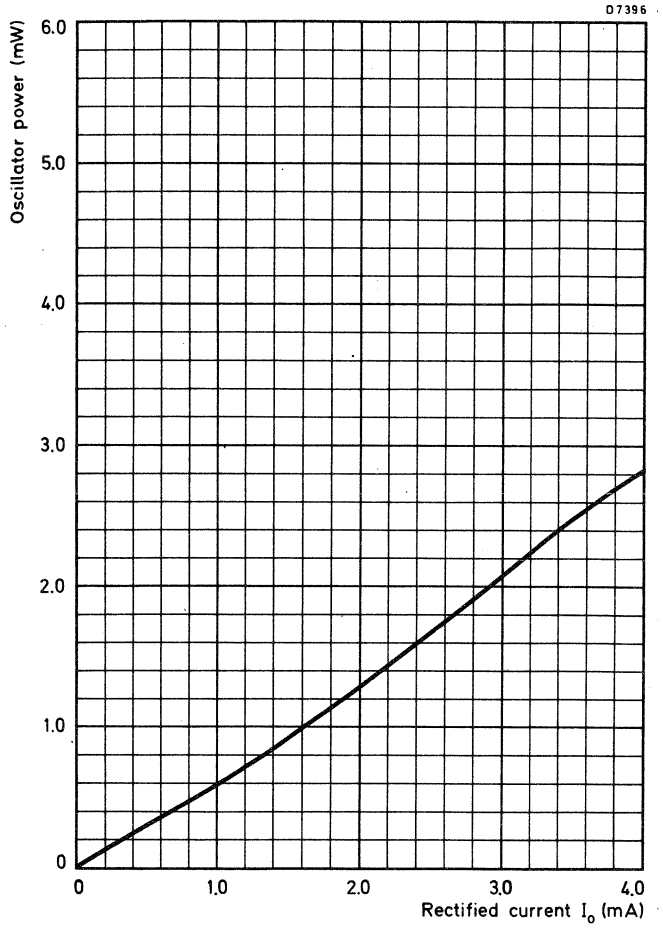

Typical rectified current as a function of local oscillator power

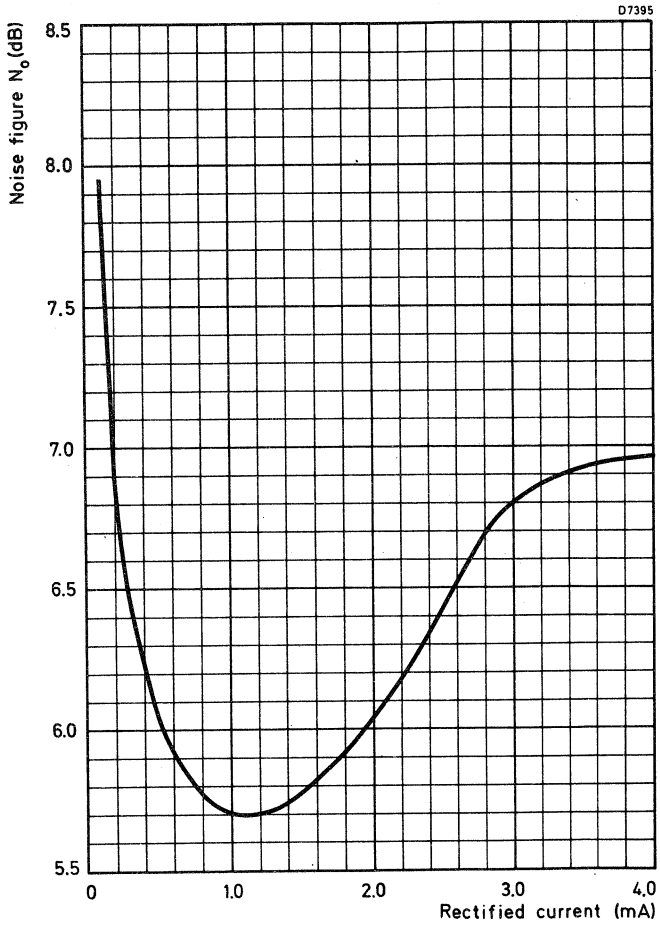

Typical noise figure as a function of rectified current

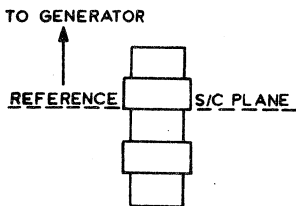
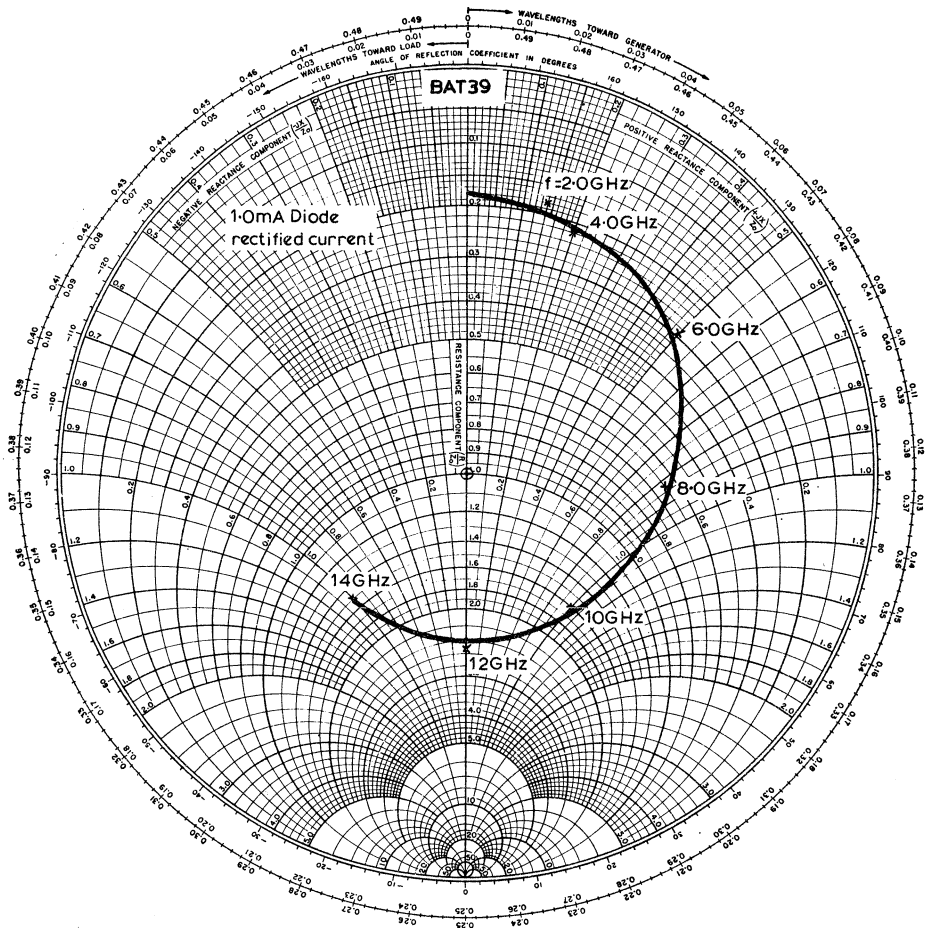

Typical r.f. admittance as a function of radio frequency
Admittance with respect of 1/50 mho. Measured in 50Ω coaxial line.

MICROWAVE MIXER DIODES

Coaxial silicon Schottky barrier diodes for use in pre-tuned X-band low noise mixer circuits. They are intended for use as low noise retrofits at X-band frequencies for coaxial mixer diodes types AAY50, AAY50R etc. The two types have identical dimensions and characteristics but the polarity is reversed. Available as a matched pair as 2/BAT50MR. The pair are intended for use in balanced mixer circuits and conform to the environmental requirements of BS9300 where applicable.

QUICK REFERENCE DATA

Operating frequency	max.	12	GHz
Noise figure	typ.	6.2	dB

This data must be read in conjunction with GENERAL SAFETY RECOMMENDATIONS – MICROWAVE SEMICONDUCTORS

MECHANICAL DATA

Dimensions in mm

Conforms to MO-74

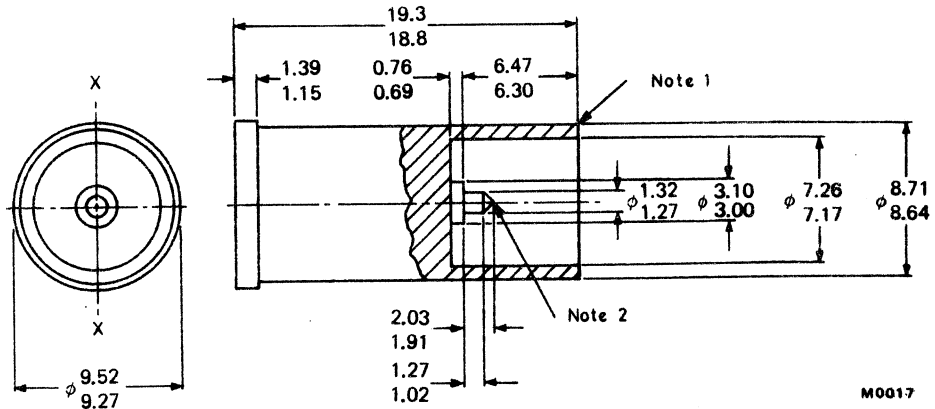

Terminal identification

BAT50	Pin	cathode	BAT50R	Pin	anode
	Body (red spot)	anode		Body (green spot)	cathode

ACCESSORIES

Holders to fit these coaxial diodes are available in the U.K. from Marconi Instruments (Sanders Division) Gunnels Wood Rd., Stevenage, Herts.

Note 1 The device is designed to make contact on this open face.

Note 2 Cone tapers to a radius of 0.13 mm nominal.

RATINGS

Limiting values in accordance with the Absolute Maximum System (IEC134)

Temperature

Storage temperature range	T_{stg}	-55 to +100	°C
Ambient temperature range	T_{amb}	-55 to +100	°C

Burn-out

R.F. spike	max.	0.2	erg
Peak pulse power ($t_p = 0.5 \mu s$)	max.	1.0	W

CHARACTERISTICS ($T_{amb} = 25 \text{ }^\circ\text{C}$)

→ Reverse current ($V_R = 0.5 \text{ V}$)	I_R	max.	2.0	μA
→ Forward current ($V_F = 0.5 \text{ V}$)	I_F	min.	2.0	mA
Overall noise figure (note 1) f = 9.375 GHz, rectified current = 1.0 mA, $R_L = 15 \Omega$, N_o includes $N_{if} = 1.5 \text{ dB}$	N_o	typ. max.	6.2 6.8	dB dB
Conversion loss	L_c		4.4	dB
Noise temperature ratio I.F. = 45 MHz	N_r		1.1:1	
→ Voltage standing wave ratio (notes 1 and 2) f = $9375 \pm 10\%$ MHz, rectified current 1.0 mA $R_L = 15 \Omega$, N_o includes $N_{if} = 1.5 \text{ dB}$	v.s.w.r.	typ. max.	1.4:1 2.0:1	
Intermediate frequency impedance	Z_{if}	min. max.	300 500	Ω Ω
Operating frequency range	f	max.	12	GHz

Notes

1. Measured in standard holder (K1007, Issue 3, Section 8B3.3.1/2).
2. The nominal rectifier admittance at a plane 7.01 mm inside the body from the open end is

$$\frac{1}{83.5} + \frac{j}{350} \text{ mho}$$

OPERATING NOTE

These devices will exhibit their inherent improved noise figure performance over the frequency range 1.0 to 12 GHz, but are not recommended for use as direct replacements in pre-tuned mounts designed for the AAY50 type coaxial diode, at other than X-band frequencies.

APPLICATION INFORMATION

Signal/Flicker noise ratio

f = 9.5 GHz. Measured at 2 kHz from carrier
in 70 Hz bandwidth

typ. 131 dB

Detector performance

Tangential sensitivity, f = 9.375 GHz,
video bandwidth = 1.0 MHz, I_F (bias) = 50 μ A
video impedance, I_F (bias) = 50 μ A

S_t	typ.	-52	dBm
Z_v	typ.	800	Ω

NOTE

Matched pairs of diodes are available to customer specifications.



MICROWAVE MIXER DIODES

The BAT51 and BAT51R form a reverse pair of mixer diodes for use in balanced mixer circuits at J-band (Ku-band). They are of silicon Schottky barrier construction and are intended as retrofits for AAY51 and AAY51R, (CV7776 and CV7777). They are packaged in the standard coaxial outline for this band, similar to 1N78 types. The encapsulation is hermetically sealed and cadmium plated. The diodes conform to the environmental requirements of BS9300 where applicable and are available as a matched pair as 2/BAT51MR, (CV7778). Can be supplied to NATO stock Nos. 5961-99-037-5472 (BAT51), 5961-99-037-5473 (BAT51R) and 5961-99-037-5474 (2/BAT51MR).

QUICK REFERENCE DATA

Frequency range		12 to 18	GHz
Noise figure	typ.	7.0	dB

This data must be read in conjunction with GENERAL SAFETY RECOMMENDATIONS – MICROWAVE SEMICONDUCTORS

MECHANICAL DATA

Dimensions in mm

Conforms to SOD-49
Similar to JEDEC DO-37

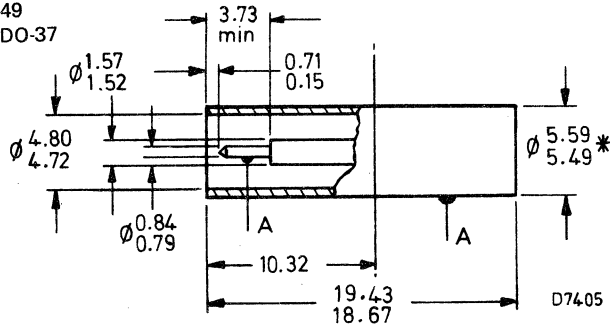

A = concentricity tolerance = ± 0.35

*These limits apply only to the 10.32 dimension

Terminal identification

BAT51 Pin cathode
Body (red) anode

BAT51R Pin anode
Body (green) cathode

BAT51 BAT51R

RATINGS

Limiting values in accordance with the Absolute Maximum System (IEC134)

Temperature

Storage temperature range	T_{stg}	-55 to +100	°C
Ambient temperature range	T_{amb}	-55 to +100	°C

Burn out

$f = 9.375$ GHz, multiple r.f. spike, spike width at half peak power = 2 ns		max.	0.05	erg
Peak pulse power $f = 9.375$ GHz, $t_p = 1.0$ μ s		max.	0.5	W

CHARACTERISTICS ($T_{amb} = 25$ °C)

→ Reverse current $V_R = 0.5$ V	I_R	max.	2.0	μ A
→ Forward current $V_F = 0.5$ V	I_F	min.	2.0	mA
Overall noise figure $f = 13.5$ GHz, N_o includes $N_{if} = 1.5$ dB Measured in JAN 201 holder. BS9300, method 1406	N_o	typ. max.	7.0 7.5	dB dB
Conversion loss	L_C		5.2	dB
Noise temperature ratio I.F. = 45 MHz. BS9300, method 1407	N_r		1.1:1	
→ Voltage standing wave ratio $f = 13.5$ GHz, rectified current = 0.9 mA		typ. max.	1.5:1 2.0:1	
Intermediate frequency impedance	Z_{if}	min. typ. max.	250 350 450	Ω Ω Ω
Operating frequency range	f		12 to 18	GHz

As a matched pair

Maximum unbalance conditions,
 $Z_{if} = 25$ Ω , rectified current 0.1 mA.

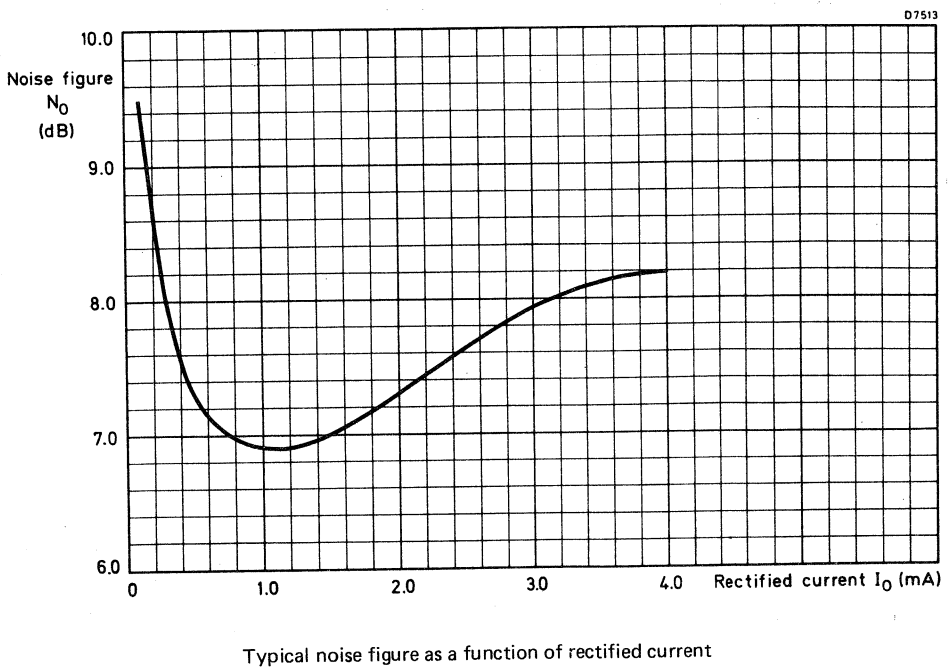
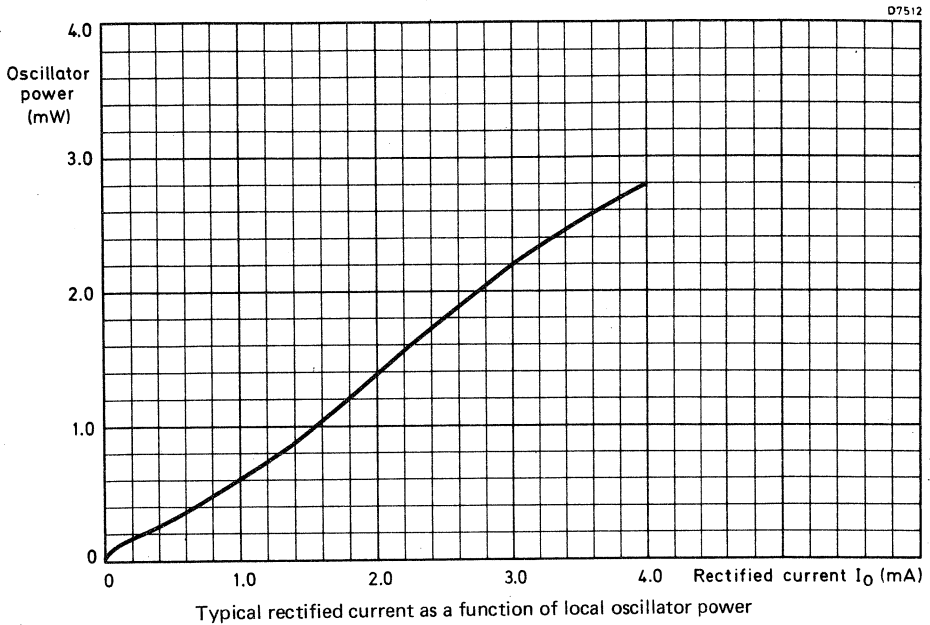

MICROWAVE MIXER DIODES

The BAT52 and BAT52R form a reverse pair of mixer diodes for use in balanced mixer circuits at J-band (Ku band). The diodes are of silicon Schottky barrier construction and are intended as retrofits for AAY52 and AAY52R. They are packaged in the standard coaxial outline for this band, similar to IN78 types. The encapsulation is hermetically sealed and cadmium plated. The devices conform to the environmental requirements of BS9300 where applicable. Available as a matched pair as 2/BAT52MR.

QUICK REFERENCE DATA

Frequency range	12 to 18	GHz
Noise figure	8.0	dB

This data must be read in conjunction with GENERAL SAFETY RECOMMENDATIONS – MICROWAVE SEMICONDUCTORS

MECHANICAL DATA

Dimensions in mm

Conforms to SOD-49
Similar to JEDEC DO-37

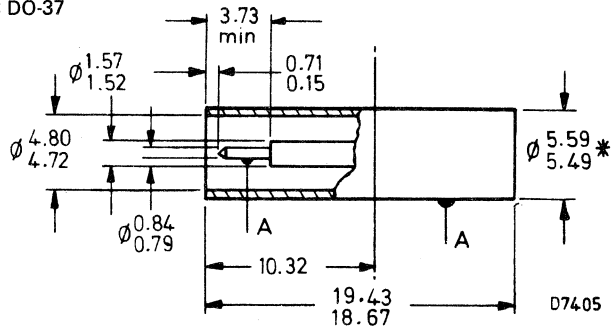

A = concentricity tolerance = ± 0.35

*These limits apply only to the 10.32 dimension

Terminal identification

BAT52	Pin	cathode	BAT52R	Pin	anode
	Body (red)	anode		Body (green)	cathode

BAT52 BAT52R

RATINGS

Limiting values in accordance with the Absolute Maximum System (IEC134)

Temperature

Storage temperature range	T_{stg}	-55 to +100	°C
Ambient temperature range	T_{amb}	-55 to +100	°C

Burn-out

$f = 9.375$ GHz, multiple r.f. spike,
spike width at half peak power = 2 ns

	max.	0.05	erg
--	------	------	-----

Peak pulse power
 $f = 9.375$ GHz, $t_p = 1.0$ μ s

	max.	0.5	W
--	------	-----	---

CHARACTERISTICS ($T_{amb} = 25$ °C)

→ Reverse current $V_R = 0.5$ V	I_R	max.	2.0	μ A
→ Forward current $V_F = 0.5$ V	I_F	min.	2.0	mA
Overall noise figure $f = 13.5$ GHz, N_o includes $N_{if} = 1.5$ dB Measured in JAN 201 holder. BS9300, method 1406	N_o	typ. max.	8.0 8.5	dB dB
Conversion loss	L_C		5.2	dB
Noise temperature ratio I.F. = 45 MHz. BS9300, method 1407	N_r		1.1:1	
→ Voltage standing wave ratio $f = 13.5$ GHz, rectified current = 0.9 mA		typ. max.	1.5:1 2.0:1	
Intermediate frequency impedance	Z_{if}	min. typ. max.	250 350 450	Ω Ω Ω
Operating frequency range	f		12 to 18	GHz

As a matched pair

Maximum unbalance conditions, $Z_{if} = 25$ Ω , rectified current 0.1 mA.

MICROWAVE MIXER DIODES

Coaxial Schottky barrier diodes for use in pre-tuned X- and S-band low noise mixer circuits. The diodes are suitable as replacements for most British coaxial point contact types in these bands, for example, GEM3, GEM4, CV7108, CV7109, CV2154 and CV2155. They conform to the environmental requirements of BS9300 where applicable. Available as a matched pair as 2/BAV22MR.

QUICK REFERENCE DATA

Operating frequency	max.	12	GHz
Noise figure at X-band	typ.	7.0	dB
at S-band	typ.	6.0	dB

This data must be read in conjunction with GENERAL SAFETY RECOMMENDATIONS – MICROWAVE SEMICONDUCTORS

MECHANICAL DATA

Dimensions in mm ←

Similar to BS3934 SO-26
Conforms to MOA-22

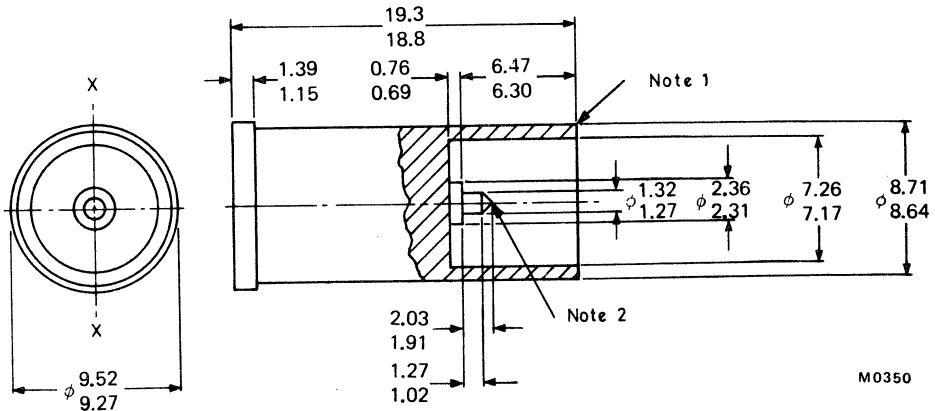

Terminal identification

BAV22	Pin	cathode	BAV22R	Pin	anode
	Body (red spot)	anode		Body (green spot)	cathode

ACCESSORIES

Holders to fit these coaxial diodes are available in the U.K. from Marconi Instruments.

Note 1 The device is designed to make contact on this open face.
Note 2 Cone tapers to a radius of 0.13 mm nominal.

RATINGS

Limiting values in accordance with the Absolute Maximum System (IEC134)

Temperature

Storage temperature range	T_{stg}	-55 to +100	°C
Ambient temperature range	T_{amb}	-55 to +100	°C

Burn-out

Multiple r.f. spikes, $\Delta N_O = 1$ dB		max.	0.2	erg
Peak pulse power, $f = 9.375$ GHz, $t_p = 0.5$ μ s		max.	1.0	W

CHARACTERISTICS ($T_{amb} = 25$ °C)

Reverse current $V_R = 2.0$ V	I_R	max.	2.0	μ A
Forward current $V_F = 0.5$ V	I_F	typ.	4.0	mA
Overall noise figure $f = 9.375$ GHz, rectified current = 1.0 mA, $R_L = 15$ Ω , N_O includes $N_{if} = 1.5$ dB, with i.f. = 45 MHz. BS9300, method 1406.	N_O	typ. max.	7.0 7.5	dB dB
$f = 3.0$ GHz	N_O	typ.	6.0	dB
Voltage standing wave ratio $f = 9375 \pm 10\%$ MHz, rectified current 1.0 mA $R_L = 15$ Ω using CV2154 holder. BS9300, method 1409.	v.s.w.r.	typ. max.	1.4:1 2.0:1	
Intermediated frequency impedance $f = 9.375$ GHz, rectified current 1.0 mA $R_L = 15$ Ω , i.f. = 45 MHz. BS9300, method 1406.		min. max.	300 550	Ω Ω
Operating frequency range	f	max.	12	GHz

NOTE

Matched pairs of diodes are available to customer specifications.

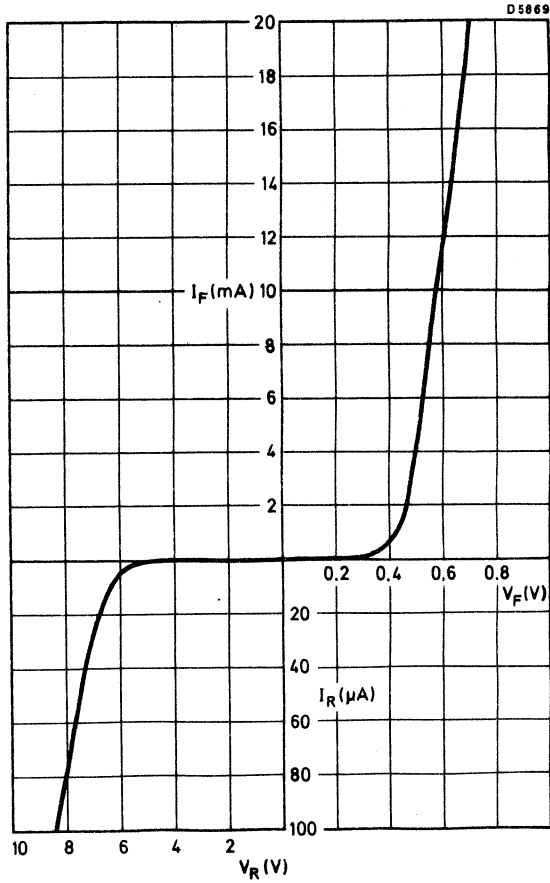

Typical d.c. characteristic

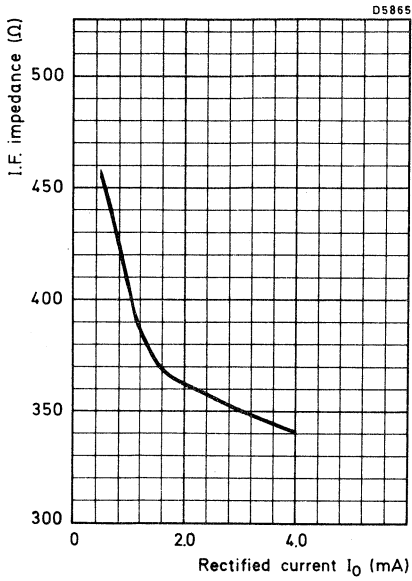

Typical i.f. impedance
as a function of rectified current

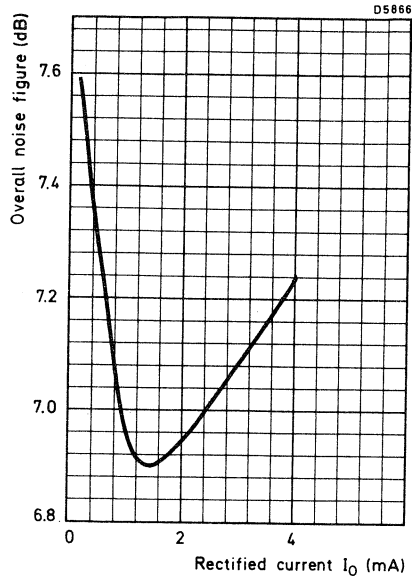

Typical overall noise figure
as a function of rectified current

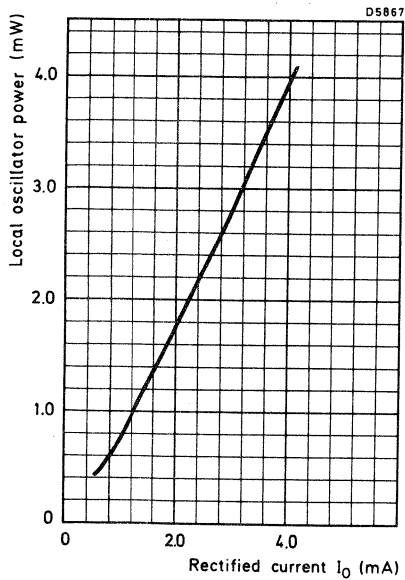

Typical local oscillator power
as a function of rectified current

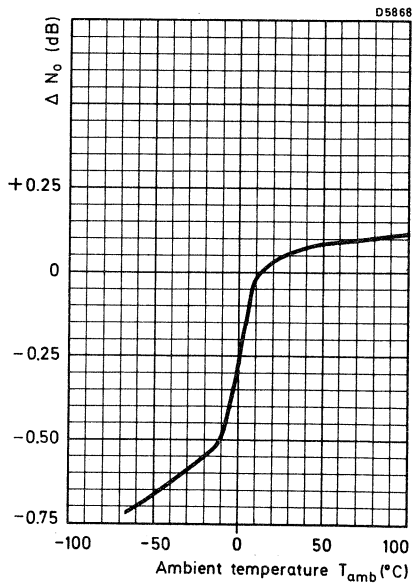

Typical change in overall noise figure
as a function of temperature.

MICROWAVE MIXER DIODE

Silicon Schottky barrier mixer diode for use in low noise mixer applications in Q-band. It conforms to the environmental requirements of BS9300 where applicable and can be supplied to NATO stock No. 5961-99-038-0541. Available as a matched pair 2/BAV72M.

QUICK REFERENCE DATA

Frequency range		26 to 40	GHz
Noise figure	typ.	8.5	dB

This data must be read in conjunction with GENERAL SAFETY RECOMMENDATIONS – MICROWAVE SEMICONDUCTORS

MECHANICAL DATA

Conforms to SOD-50

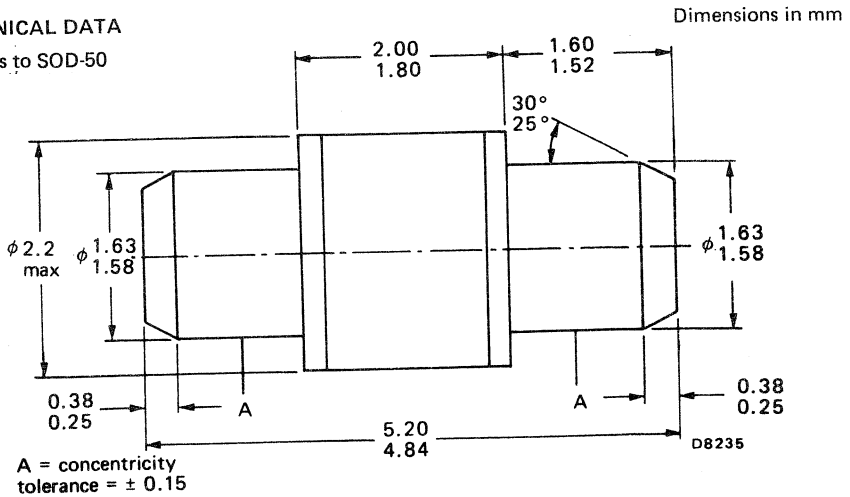

Terminal identification: red end indicates cathode

→ RATINGS

Limiting values in accordance with the Absolute Maximum System (IEC134)

Burn-out (r.f. spike) (note 1)			0.04	erg
Burn-out, peak pulse power		max.	0.5	W
Storage temperature range	T_{stg}		-55 to +100	°C
Ambient temperature range	T_{amb}		-55 to +100	°C

→ CHARACTERISTICS ($T_{amb} = 25\text{ °C}$)**Static**

Reverse current ($V_R = 0.5\text{ V}$)	I_R	max.	2.0	μA
Forward current ($V_F = 0.5\text{ V}$)	I_F	min.	2.0	mA

Dynamic

Noise figure (note 2)	N_o	typ.	8.5	dB
		max.	10	dB
Voltage standing wave ratio (note 3)	v.s.w.r.	typ.	1.8:1	
		max.	2.0:1	
Intermediate frequency impedance (note 4)	Z_{if}	min.	700	Ω
		max.	1100	Ω
Frequency range	f	min.	26	GHz
		max.	40	GHz
Conversion loss (note 5)	L_c	typ.	5.9	dB
Noise temperature ratio (note 6)	N_r	typ.	1.4:1	

Notes

- Local oscillator frequency = 9.375 GHz, number of pulses = 6×10^5 , pulse duration = 2 ns at half peak energy, p.r.f. = 2000 p.p.s., load resistance = 0 Ω . $T_{amb} = 25\text{ °C}$.
- Measured with a local oscillator frequency of 34.86 GHz, $I_o = 0.5\text{ mA}$, load resistance = 15 Ω , i.f. = 45 MHz. BS9300, method 1406.
- Measured with a local oscillator frequency of 34.86 GHz, $I_o = 0.5\text{ mA}$, load resistance = 15 Ω . BS9300, method 1409.
- Measured with a local oscillator frequency of 34.86 GHz, $I_o = 0.5\text{ mA}$, load resistance = 15 Ω , i.f. = 45 MHz. BS9300, method 1405.
- Measured at 34.86 GHz, 450 μW local oscillator power level and load resistance = 1 $\text{k}\Omega$.
- Measured at 34.86 GHz and i.f. = 45 MHz.
- The diodes are measured in fixed tuned Q-band waveguide mounts. Details may be obtained from the manufacturer.
- Matched pairs of diodes are available to customer specifications

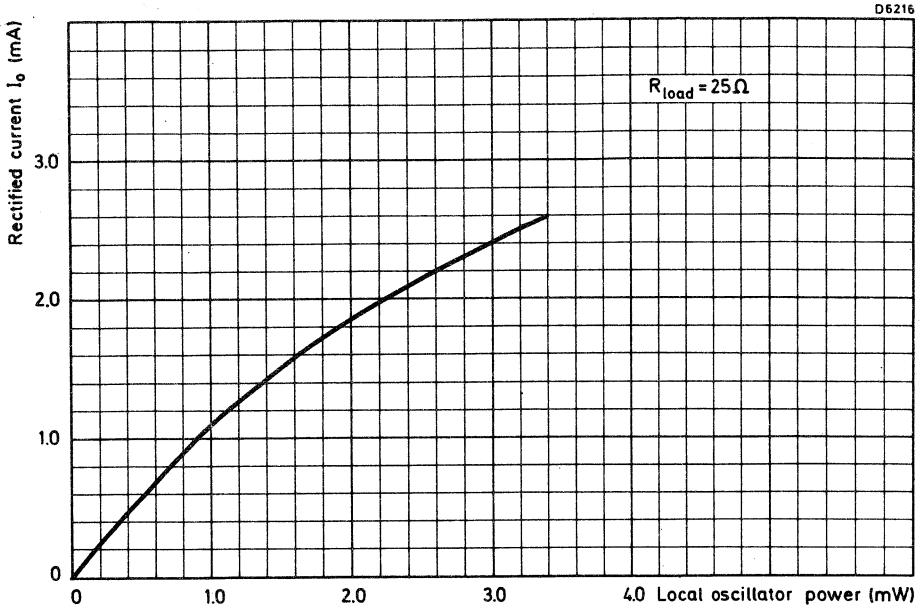

Typical rectified current as a function of local oscillator power at 34.86 GHz

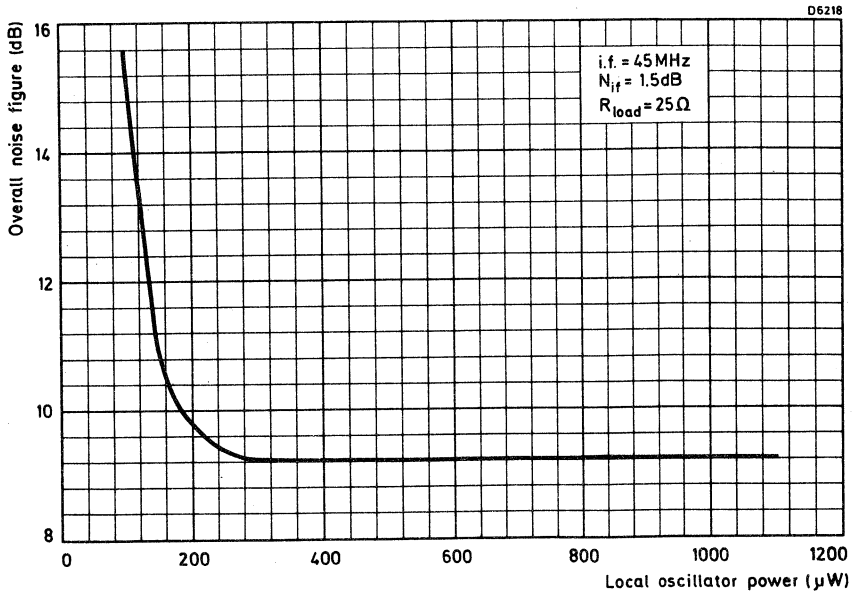

Typical overall noise figure as a function of local oscillator power at 34.86 GHz

MICROWAVE DETECTOR DIODE

Silicon Schottky barrier diode specially designed for use in Doppler radars where high detector sensitivity is required. It conforms to the environmental requirements of BS9300 where applicable.

QUICK REFERENCE DATA

Frequency range	8 to 12	GHz
Tangential sensitivity with 100 μ A bias	typ. -50	dBm

This data must be read in conjunction with GENERAL SAFETY RECOMMENDATIONS - MICROWAVE SEMICONDUCTORS

MECHANICAL DATA

Dimensions in mm ←

Conforms to BS 3934 SO-86 and to SOD-31

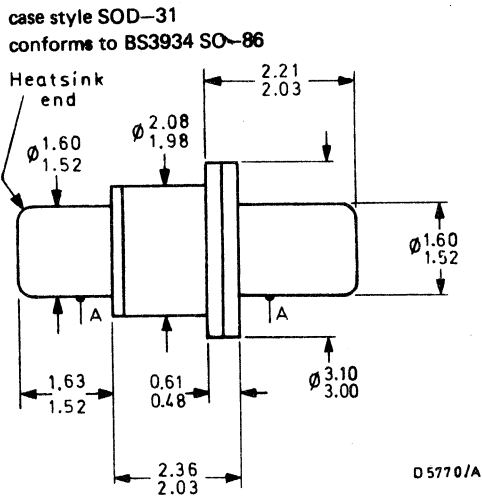

A = concentricity tolerance = ± 0.13

$C_S = 0.25\text{pF typ.}$
 $L_S = 0.65\text{nH typ.}$



RATINGS

Limiting values in accordance with the Absolute Maximum Rating System (IEC134)

Storage temperature range	-55 to +150	°C
Ambient temperature range	-55 to +150	°C
Peak pulsed r.f. input power at 9.375 GHz, 0.5 μ s pulse length	max. 0.75	W

CHARACTERISTICS ($T_{amb} = 25\text{ }^{\circ}\text{C}$)

		min.	typ.	max.	
Voltage standing wave ratio (notes 1, 2 and 3)	v.s.w.r.	—	1:4:1	2:1	
Video impedance (notes 4 and 5)	Z_v	—	310	—	Ω
Tangential sensitivity (notes 1 and 2)	S_{ts}	-49	-50	—	dBm
Flicker noise (notes 4 and 5)	$1/f$	—	10	15	dB

Notes

1. Measured at 10.687 GHz with 100 μ A forward bias.
2. Measured in a reduced height waveguide mount.
3. R.F. input power less than 5 μ W.
4. Measured with 100 μ A forward bias.
5. Maximum d.c. input voltage = 1 mV.
6. a) Measured at an i.f. of 1 kHz with 50 Hz bandwidth.
b) $1/f$ noise remains constant with a forward bias not exceeding 250 μ A.

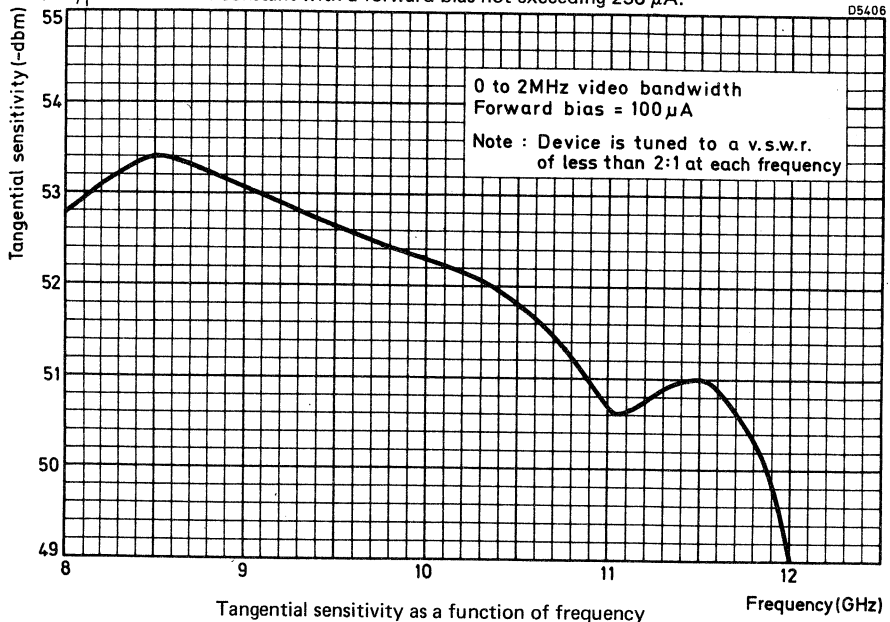

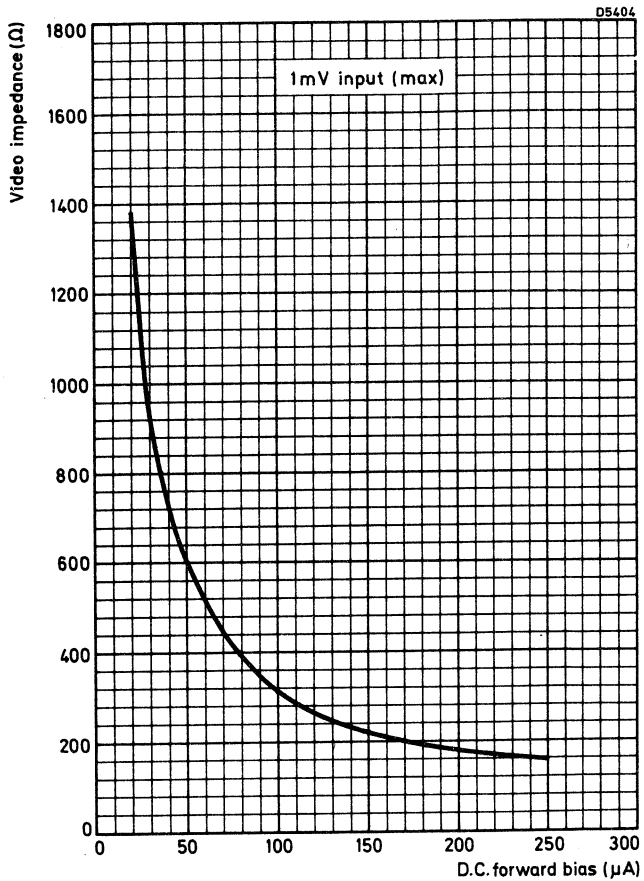

Video impedance as a function of d.c. forward bias

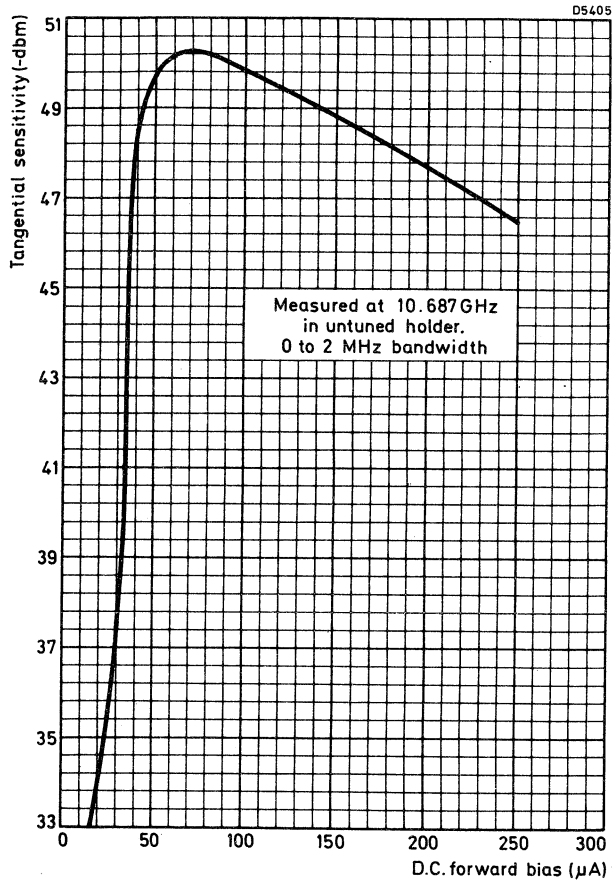

Tangential sensitivity as a function of d.c. forward bias

MICROWAVE MIXER DIODES

A range of sub-miniature reversible low noise Schottky barrier mixer diodes. The planar technology employed imparts a high degree of reliability and reproducibility. The metal-ceramic case is hermetically sealed and the devices conform to the environmental requirements of BS9300 where applicable.

QUICK REFERENCE DATA

Noise figure in X-band

BAV96A	max.	7.5	dB
BAV96B	max.	7.0	dB
BAV96C	max.	6.5	dB
BAV96D	max.	6.0	dB
Operating frequency	max.	12	GHz

This data must be read in conjunction with GENERAL SAFETY RECOMMENDATIONS – MICROWAVE SEMICONDUCTORS

MECHANICAL DATA

Dimensions in mm

Conforms to SOD-50

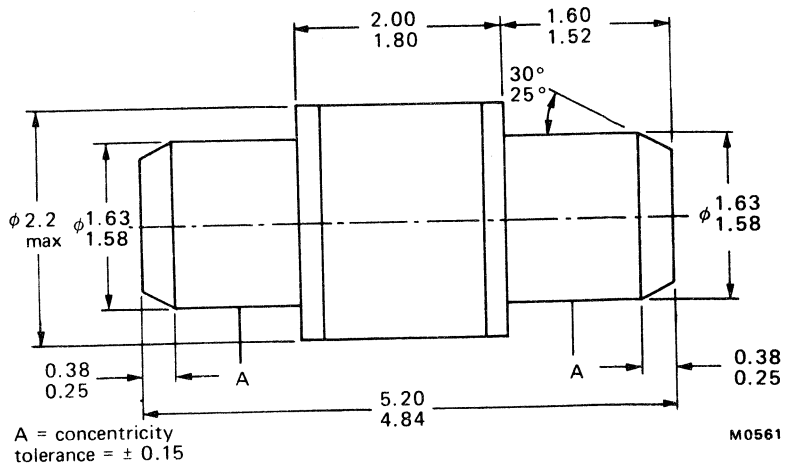

Terminal identification: red end indicates cathode

RATINGS

Limiting values in accordance with the Absolute Maximum System (IEC134)

Storage temperature range	T_{stg}	-55 to +150	$^{\circ}C$
Ambient temperature range	T_{amb}	-55 to +150	$^{\circ}C$
Burn-out (note 1)	max.	15	nJ

CHARACTERISTICS ($T_{amb} = 25^{\circ}C$)

			min.	typ.	max.	
Noise figure (note 2)	BAV96A	N_o	-	7.0	7.5	dB
	BAV96B		-	6.5	7.0	
	BAV96C		-	6.0	6.5	
	BAV96D		-	5.5	6.0	
Voltage standing wave ratio (note 3)	BAV96A	v.s.w.r.	-	1.7:1	2.0:1	
	BAV96B		-	1.4:1	1.6:1	
	BAV96C		-	1.4:1	1.6:1	
	BAV96D		-	1.3:1	1.5:1	
I.F. impedance (note 4)		Z_{if}	250	-	450	Ω
Tangential sensitivity (note 5)		S_{ts}	-	-52	-	dBm
Tangential sensitivity (note 6)		S_{ts}	-	-54	-	dBm

NOTES

- Burn out is defined as the r.f. pulse energy necessary to cause 1 dB degradation in noise figure when the diode is subjected to 2×10^8 pulses of 2 ns width.
- Measured at 9.375 ± 0.1 GHz. The noise figure includes i.f. amplifier contribution of 1.5 dB, i.f. 45 MHz, d.c. return for diode 15Ω max., rectified current 1 mA. BS9300, method 1406.
- Measured in a reduced height waveguide mount under the same test conditions as in note 2. BS9300, method 1409.
- I.F. = 45 MHz, $R_L = 15 \Omega$, $f = 9.375 \pm 0.1$ GHz, $I_o = 1$ mA. BS9300, method 1405.
- Video bandwidth 0 to 2 MHz, $30 \mu A$ bias. BS9300, method 1411.
- Video bandwidth 1 kHz to 1 MHz, $30 \mu A$ bias. BS9300, method 1411.
- A suitable holder for this diode is a modified version of Sanders type 6521.

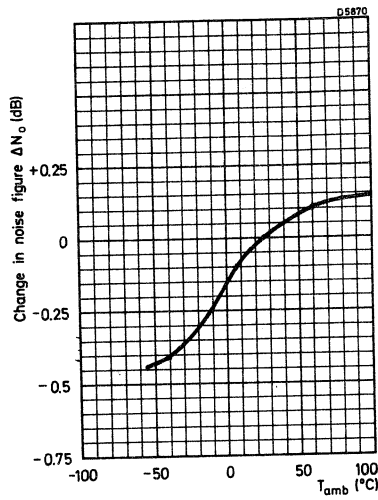

Typical change in overall noise figure as a function of temperature

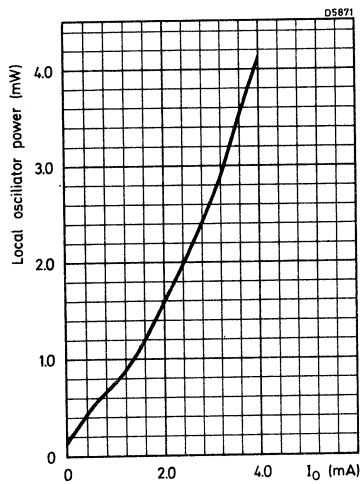

Typical local oscillator power as a function of rectified current

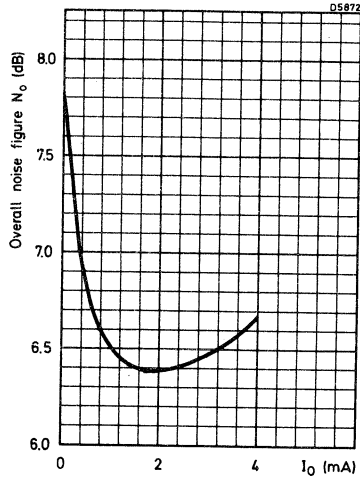

Typical overall noise figure as a function of rectified current

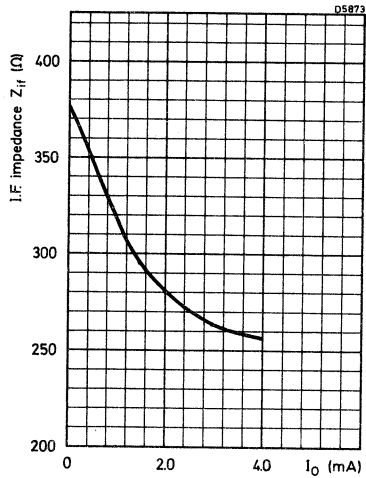

Typical i.f. impedance as a function of rectified current

MICROWAVE DETECTOR DIODE

A reversible silicon Schottky barrier diode with excellent sensitivity and very low $1/f$ noise. It conforms to the environmental requirements of BS9300 where applicable. The metal-ceramic case is hermetically sealed.

QUICK REFERENCE DATA

Operating frequency	f	max.	12	GHz
Tangential sensitivity	S_{ts}	typ.	-54	dBm
$1/f$ noise	N_f	typ.	10	dB

This data must be read in conjunction with GENERAL SAFETY RECOMMENDATIONS – MICROWAVE SEMICONDUCTORS

MECHANICAL DATA

Dimensions in mm

Conforms to SOD-50

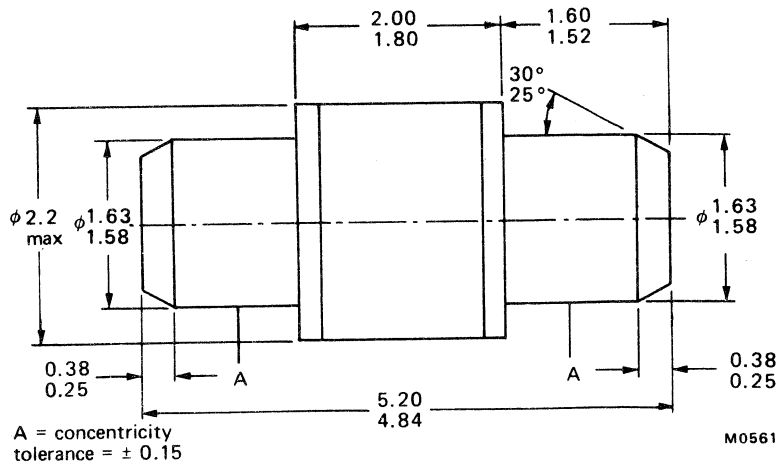

Terminal identification:

The positive end (cathode) is marked red.

RATINGS

Limiting values in accordance with the Absolute Maximum System (IEC134)

Temperature

Storage temperature range	T_{stg}	-55 to +150	°C
Ambient temperature range	T_{amb}	-55 to +150	°C

Burn-out

Burn-out (note 1)		max.	18	nJ
			0.18	erg

CHARACTERISTICS ($T_{amb} = 25\text{ °C}$)

		min.	typ.	max.	
Tangential sensitivity (note 2)	S_{ts}	-52	-54	-58	dBm
$1/f$ noise (note 3)	N_f	-	10	15	dB
Video impedance (note 4)	Z_v	-	500	-	Ω

Notes

1. Burn-out is defined as the r.f. pulse energy necessary to cause 1 dB degradation in noise figure when the diode is subjected to 2×10^8 pulses of 2 ns width.
2. Video bandwidth 0 to 2 MHz, 50 μ A bias, $f = 9.375$ GHz. BS9300, method 1411. (A 2 dBm improvement in tangential sensitivity may be obtained by limiting the bandwidth to 1 kHz to 1 MHz).
3. Measured at 30 μ A bias, $f = 1$ kHz, 50 Hz bandwidth. $1/f$ noise is unchanged with values of bias up to 150 μ A.
4. Measured at 50 μ A forward bias.

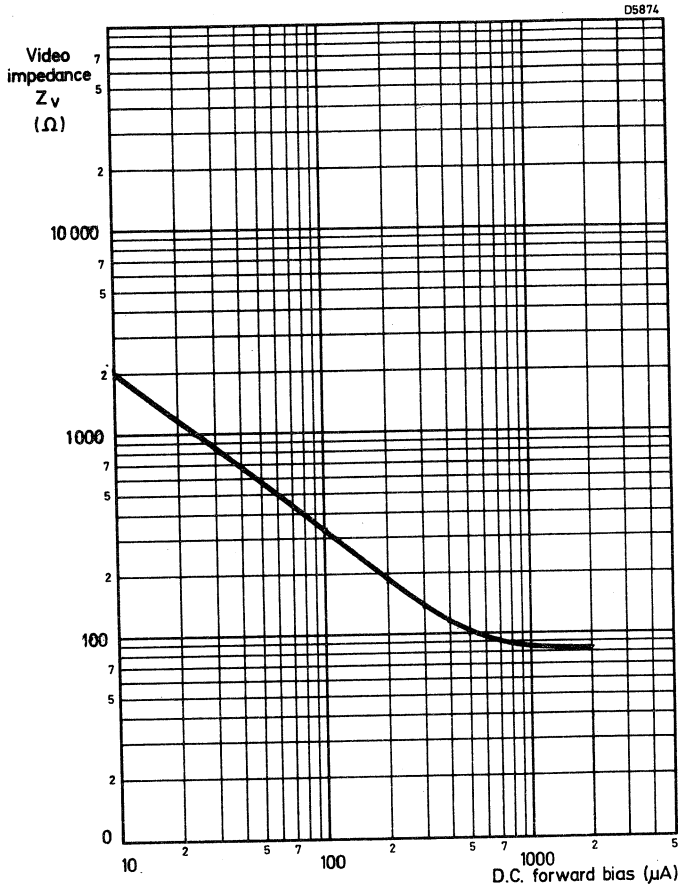

Video impedance as a function of d.c. forward bias

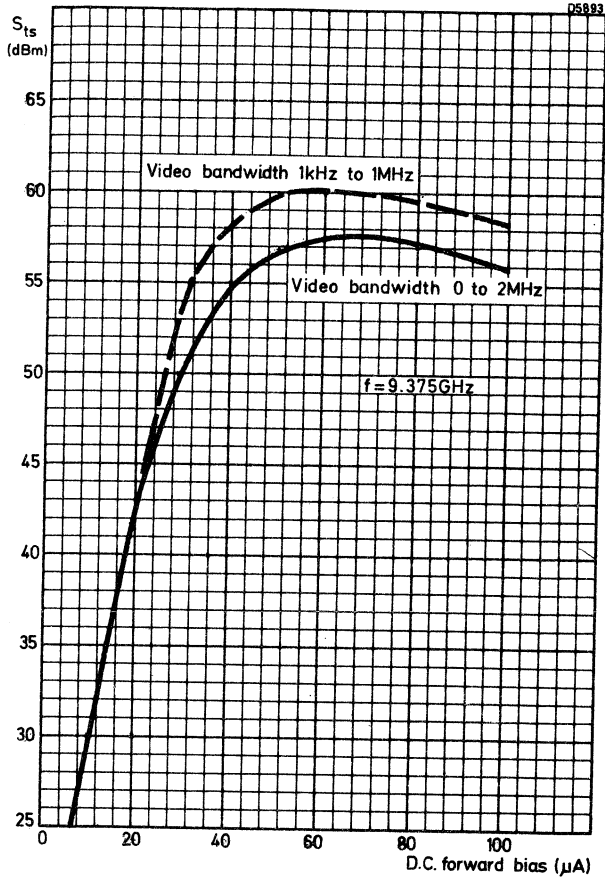

Tangential sensitivity as a function of d.c. forward bias.

MICROWAVE MIXER DIODES

A range of silicon Schottky barrier mixer diodes in reversible cartridge outline. The diodes are suitable as replacements for the 1N23 and 1N415 series and conform to environmental requirements of BS9300 where applicable.

Unless otherwise stated, data is applicable to all types.

QUICK REFERENCE DATA

Noise figure at X-band	BAW95D	N_o	max.	8.2	dB
	BAW95E		max.	7.5	dB
	BAW95F		max.	7.0	dB
	BAW95G		max.	6.5	dB

This data must be read in conjunction with GENERAL SAFETY RECOMMENDATIONS – MICROWAVE SEMICONDUCTORS

MECHANICAL DATA

Dimensions in mm

Conforms to SOD-47
Compatible with JEDEC D0-22 with collet
Compatible with JEDEC D0-23 without collet

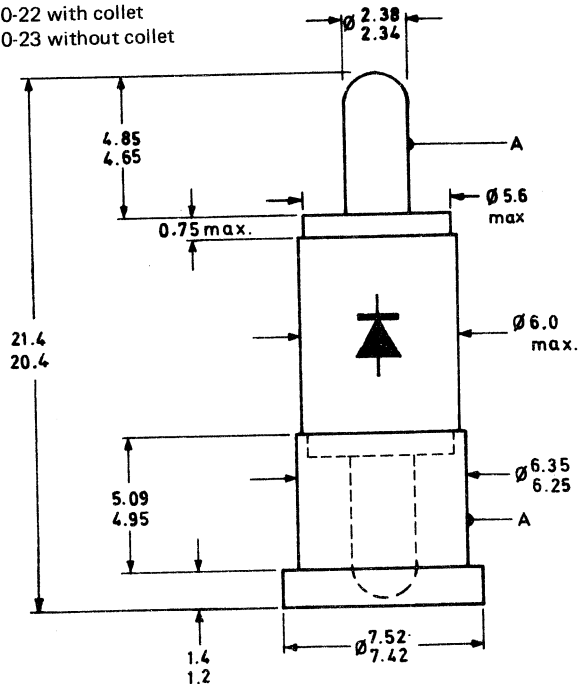

Terminal identification:

Diode symbol indicates polarity

D4868

RATINGS

Limiting values in accordance with the Absolute Maximum System (IEC134)

Temperature

Storage temperature range	T_{stg}	-55 to +150	°C
Ambient temperature range	T_{amb}	-55 to +150	°C

Burn-out

Burn-out (note 1)	max.	20	nJ
		0.2	erg
Peak pulse power f = 9.375 GHz, $t_p = 0.5 \mu s$	max.	1.0	W

CHARACTERISTICS ($T_{amb} = 25 \text{ } ^\circ\text{C}$)

		min.	typ.	max.		
Noise figure (note 2)	BAW95D	N_o	—	7.8	8.2	dB
	BAW95E		—	7.2	7.5	dB
	BAW95F		—	6.8	7.0	dB
	BAW95G		—	6.3	6.5	dB
Voltage standing wave ratio (note 3)	v.s.w.r.	—	—	—	1.3:1	
Intermediate frequency impedance (note 4)	Z_{if}	250	415	500	Ω	

Notes

1. Burn-out is defined as the r.f. pulse energy necessary to cause 1 dB degradation in noise figure when the diode is subjected to 2×10^8 pulses of 2 ns width.
2. Measured at 9.375 GHz, 1 mA rectified current, $R_L = 15 \Omega$. N_o includes $N_{if} = 1.5$ dB with 45 MHz intermediate frequency. BS9300, method 1406.
3. With respect to JAN-106 holder measured at 9.375 GHz, 1 mA rectified current, $R_L = 15 \Omega$. BS9300, method 1409.
4. Measured at 9.375 GHz, 1 mA rectified current, $R_L = 15 \Omega$ with 45 MHz intermediate frequency. BS9300, method 1405.

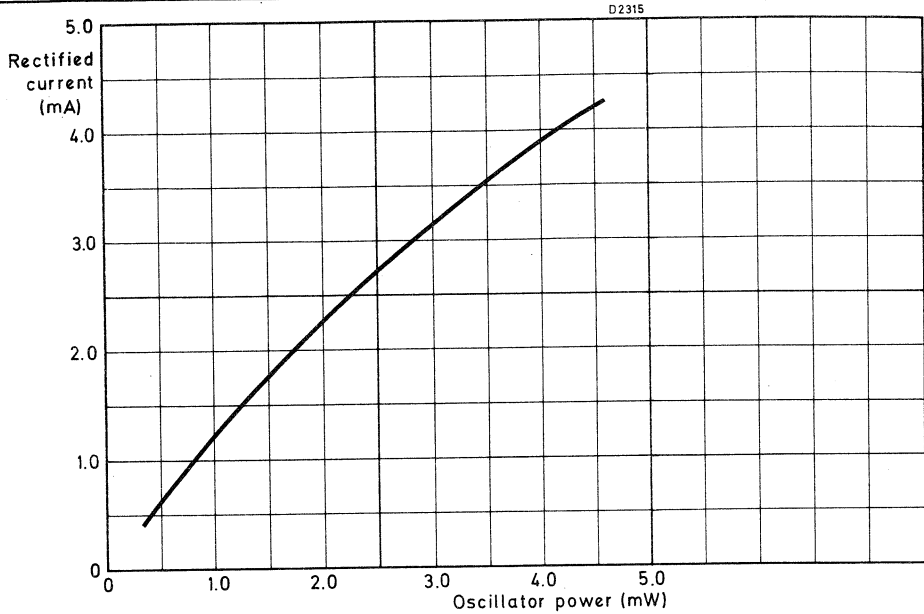

Typical rectified current as a function of local oscillator power

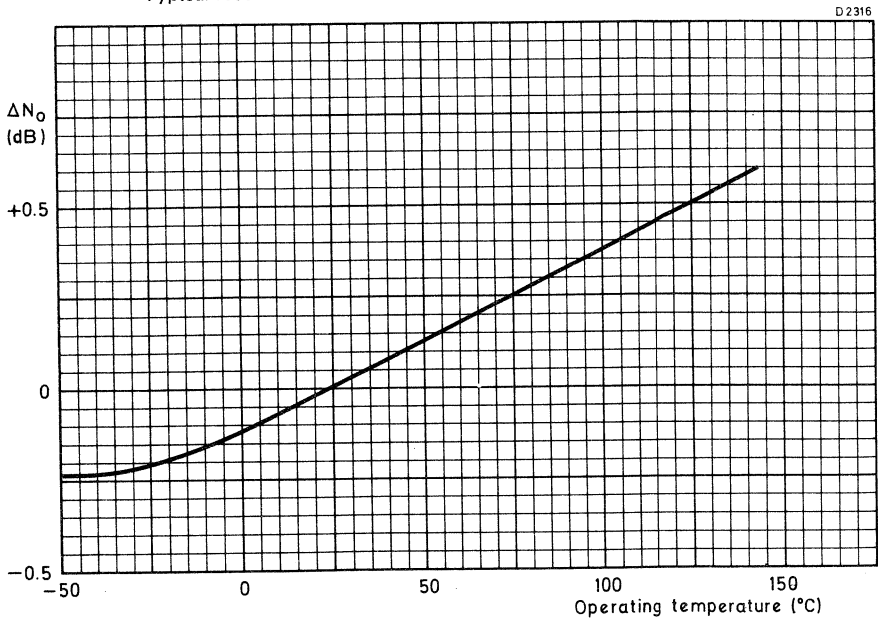

Typical change in noise figure as a function of temperature

D2313

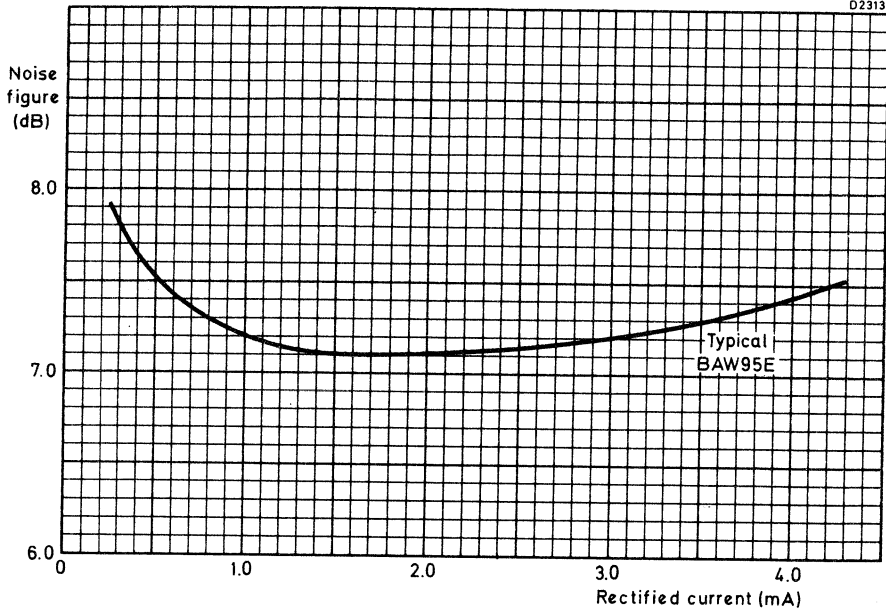

Typical noise figure as a function of rectified current

D2314

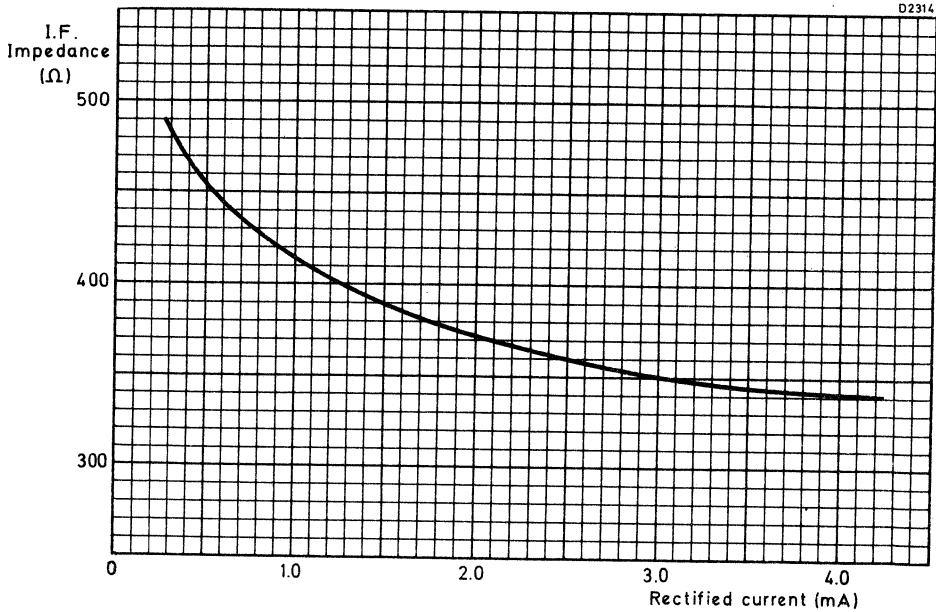

I.F. impedance as a function of rectified current

MICROWAVE MIXER DIODE

Silicon Schottky barrier mixer diode in reversible cartridge outline. It conforms to the environmental requirements of BS9300 where applicable.

QUICK REFERENCE DATA

Noise figure at X-band	N_0	max.	7.5	dB
------------------------	-------	------	-----	----

This data must be read in conjunction with GENERAL SAFETY RECOMMENDATIONS – MICROWAVE SEMICONDUCTORS

MECHANICAL DATA

Dimensions in mm

Conforms to SOD-47
 Compatible with JEDEC DO-22 with collet
 Compatible with JEDEC DO-23 without collet

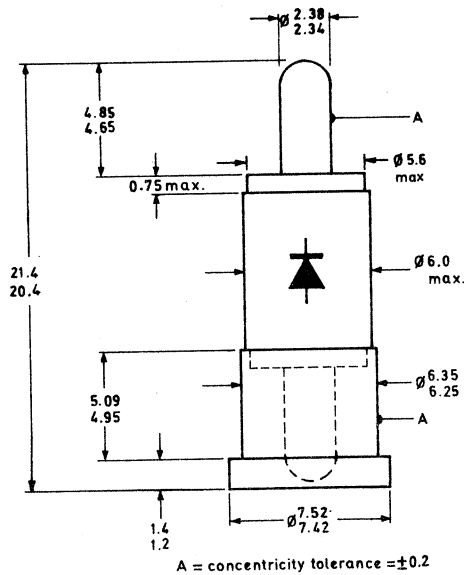

D4668

Terminal identification:

Diode symbol indicates polarity

RATINGS

Limiting values in accordance with the Absolute Maximum System (IEC134)

Temperature

Storage temperature range	T_{stg}	-55 to +150	°C
Ambient temperature range	T_{amb}	-55 to +150	°C

Burn-out

Burn-out (note 1)		max.	20	nJ
			0.2	erg
Peak pulse power $f = 9.375 \text{ GHz}$, $t_p = 0.5 \mu\text{s}$		max.	1.0	W

CHARACTERISTICS ($T_{amb} = 25 \text{ }^\circ\text{C}$)

		min.	typ.	max.	
Noise figure (note 2)	N_o	-	7.2	7.5	dB
Voltage standing wave ratio (note 3)	v.s.w.r.	-	-	1.3:1	
Intermediate frequency impedance (note 4)	Z_{if}	335	400	465	Ω

Notes

- Burn-out is defined as the r.f. pulse energy necessary to cause 1 dB degradation in noise figure when the diode is subjected to 2×10^8 pulses of 2 ns width.
- Measured at 9.375 GHz, 1 mA rectified current, $R_L = 15 \Omega$. N_o includes $N_{if} = 1.5 \text{ dB}$ with 45 MHz intermediate frequency. BS9321/1406.
- With respect to JAN-106 holder measured at 9.375 GHz, 1 mA rectified current, $R_L = 15 \Omega$. BS9321/1409.
- Measured at 9.375 GHz, 1 mA rectified current, $R_L = 15 \Omega$ with 45 MHz intermediate frequency. BS9321/1405.

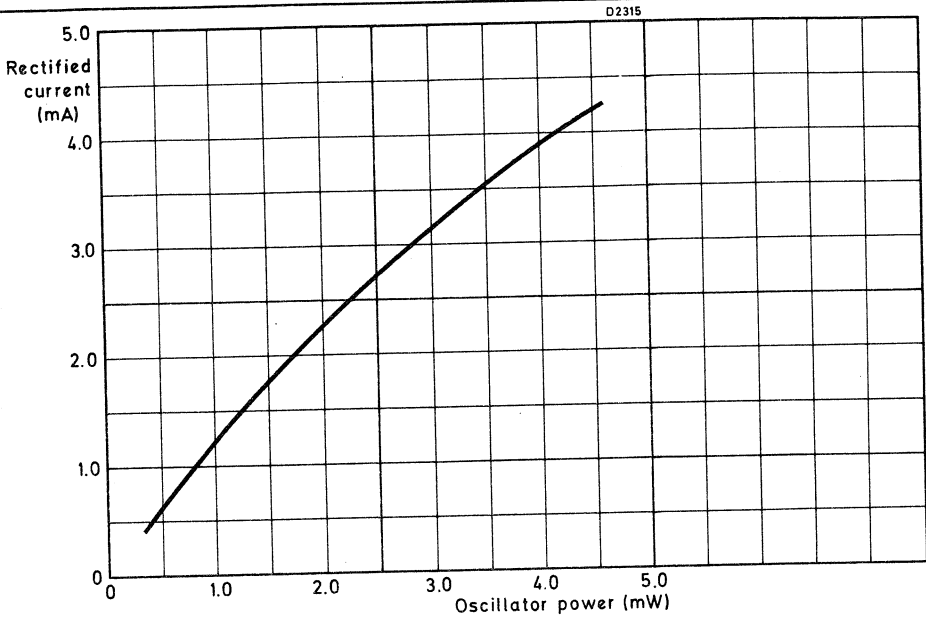

Typical rectified current as a function of local oscillator power

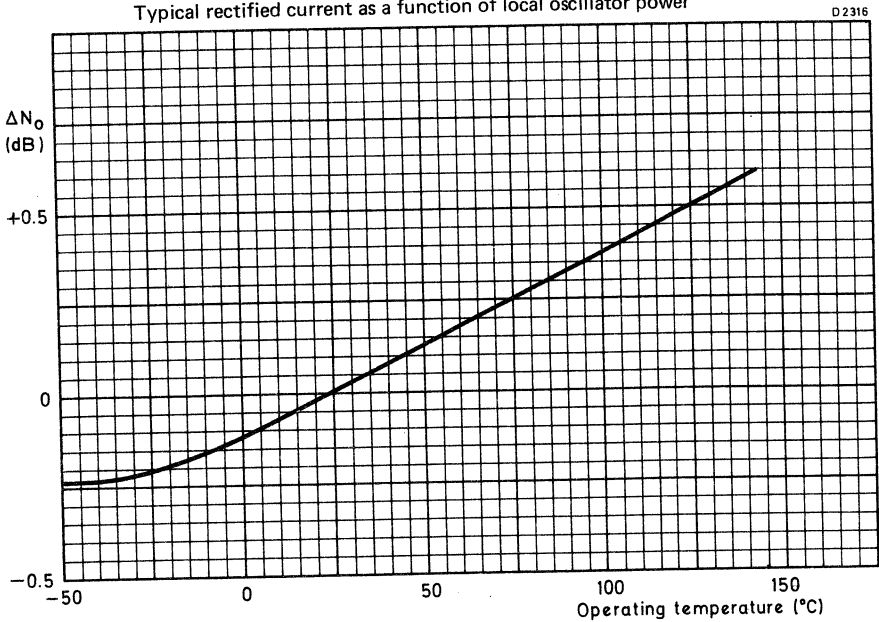

Typical change in noise figure as a function of temperature

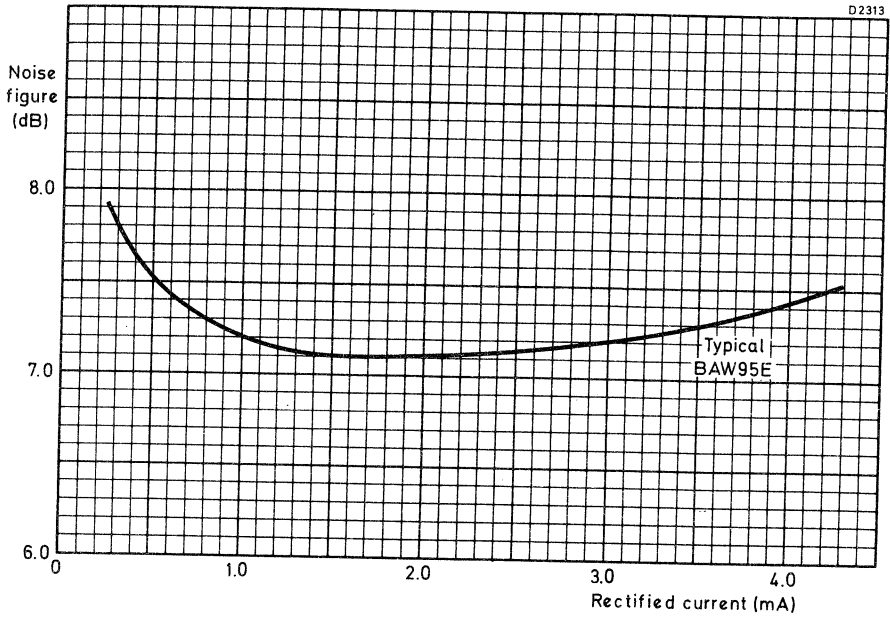

Typical noise figure as a function of rectified current

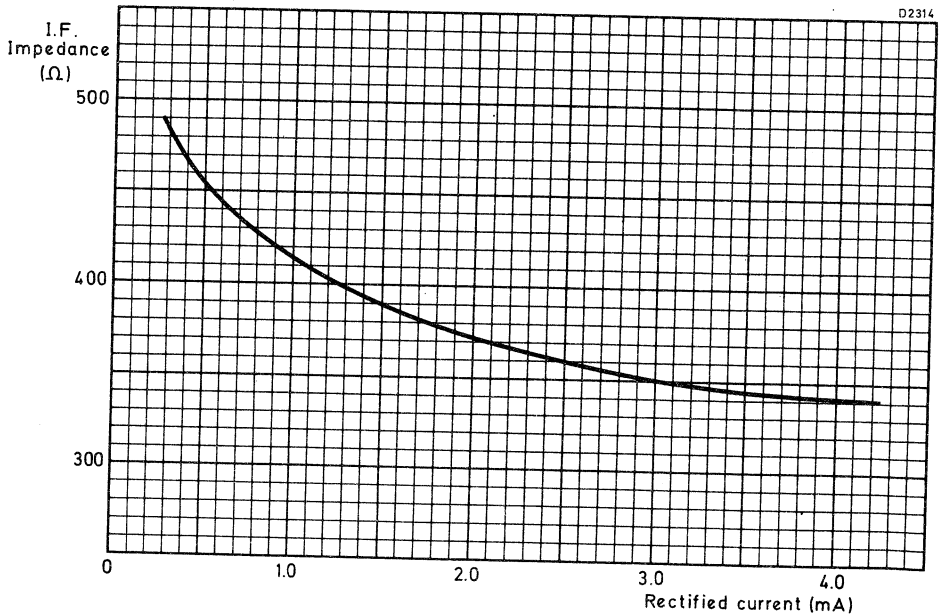

I.F. impedance as a function of rectified current

BACKWARD DIODES





D

MICROWAVE DETECTOR DIODE

Sub-miniature germanium backward diode primarily intended for broadband low level detector applications in X-band. It conforms to the environmental requirements of BS9300 where applicable.

QUICK REFERENCE DATA

Frequency range		1 to 18	GHz
Zero bias tangential sensitivity in X-band	typ.	-53	dBm

This data must be read in conjunction with GENERAL SAFETY RECOMMENDATIONS – MICROWAVE SEMICONDUCTORS

MECHANICAL DATA

Dimensions in mm

Conforms to SOD-42

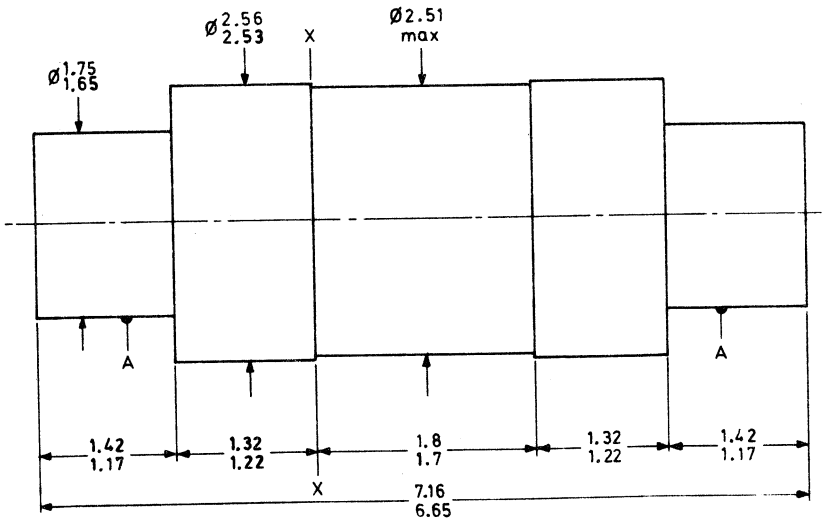

XX = reference plane

AA = concentricity tolerance = ± 0.15

D2527a

Terminal identification:

The AEY17 is colour coded as follows:

The positive end (cathode) is marked red and the negative end (anode) is marked blue.

The positive end indicates the electrode which becomes positive in an a.c. rectifier circuit.

RATINGS

Limiting values in accordance with the Absolute Maximum System (IEC134)

Storage temperature range	T_{stg}	-55 to +85	°C
Ambient temperature range	T_{amb}	-55 to +85	°C

CHARACTERISTICS ($T_{amb} = 25\text{ }^{\circ}\text{C}$)

		min.	typ.	max.	
→ Static					
Reverse current $V_R = 0.3\text{ V}$	I_R	-	12		mA
Forward current $V_F = 0.3\text{ V}$	I_F	-	100		μA
Dynamic					
Tangential sensitivity (note 1)	S_{ts}	-	-53	-	dBm
Figure of merit (note 2)	M	100	-	-	
Video impedance (note 3)	Z_V	-	300	-	Ω
Voltage standing wave ratio (note 4)	v.s.w.r.	-	-	5:1	

Notes

1. Measured at 9.375 GHz, zero bias, video bandwidth = 1.0 MHz. BS9300, method 1411.
2. Measured at 9.375 GHz, M is taken as the product of current sensitivity, expressed in μA per μW , and the square root of video impedance in ohms. BS9300, method 1414.
3. Zero bias, input 1.0 mV max (d.c. or a.c. r.m.s.). BS9300, method 1404.
4. With respect to $50\text{ }\Omega$, measured at $f = 9.375\text{ GHz}$, zero bias and c.w. input power less than $1.0\text{ }\mu\text{W}$. The nominal rectifier admittance at a reference plane X-X taken at the end faces of the ceramic insulator (see outline drawing on page 1) is:

$$(2.0 - j 2.0) \frac{1}{50} \text{ mho}$$

APPLICATION INFORMATION

1. Detector performance at other than Test Radio Frequency

		typ.	max.	
Tangential sensitivity, $f = 1.0$ to 18 GHz , $B = 1.0\text{ MHz}$	S_{ts}	-53	-	dBm
Voltage standing wave ratio, $f = 1.0$ to 18 GHz , $Z_0 = 50\text{ }\Omega$	v.s.w.r.	-	5:1	

2. Mixer performance (I.F. = 45 MHz)

Measured overall noise figure, $f = 9.375\text{ GHz}$, $N_{if} = 1.5\text{ dB}$, $P_{L.O.} = 200\text{ }\mu\text{W}$, $I_{out} = 1.0\text{ mA}$	N_o	9.0		dB
$f = 16.5\text{ GHz}$, $N_{if} = 1.5\text{ dB}$, $P_{L.O.} = 200\text{ }\mu\text{W}$, $I_{out} = 1.0\text{ mA}$		9.5	-	dB
I.F. impedance, $I_{out} = 1.0\text{ mA}$	Z_{if}	130	-	Ω
Voltage standing wave ratio, $f = 1$ to 18 GHz , $Z_0 = 50\text{ }\Omega$, $I_{out} = 1.0\text{ mA}$		-	2.5:1	

3. Doppler mixer performance (I.F. = 3 kHz)

Measured overall noise figure, $f = 9.375\text{ GHz}$, $N_{if} = 2.0\text{ dB}$	N_o	18	-	dB
--	-------	----	---	----

MICROWAVE DETECTOR DIODES

Germanium backward diodes primarily intended for low level detector applications in J-band (Ku-band). They are packaged in the standard coaxial outline for this frequency band, similar to 1N78 types. The encapsulation is hermetically sealed and is cadmium plated. The AEY29 and AEY29R conform to the environmental requirements of BS9300 where applicable.

QUICK REFERENCE DATA

Frequency range	12 to 18	GHz
Zero bias tangential sensitivity in J- band	typ. -53	dBm

This data must be read in conjunction with GENERAL SAFETY RECOMMENDATIONS – MICROWAVE SEMICONDUCTORS

MECHANICAL DATA

Dimensions in mm

Conforms to SOD-49

Similar to JEDEC DO-37

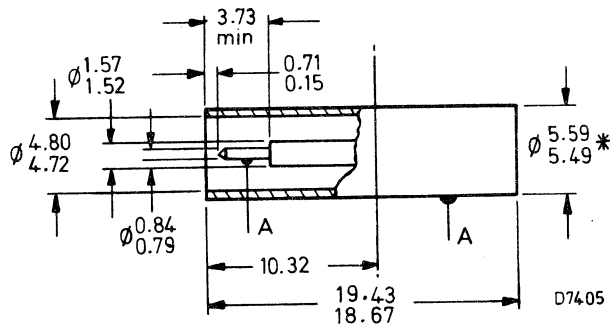

A = concentricity tolerance = ± 0.35

*These limits apply only to the 10.32 dimension

Terminal identification:

AEY29	Pin	cathode
	Body (red)	anode
AEY29R	Pin	anode
	Body (green)	cathode

AEY29
AEY29R

RATINGS

Limiting values in accordance with the Absolute Maximum System (IEC134)

Storage temperature range	T_{stg}	-55 to +85	°C
Ambient temperature range	T_{amb}	-55 to +85	°C

CHARACTERISTICS ($T_{amb} = 25\text{ °C}$)

		min.	typ.	max.	
Static					
Reverse current $V_R = 0.3\text{ V}$	I_R	-	12		mA
Forward current $V_F = 0.3\text{ V}$	I_F	-	100		μA
Dynamic					
Tangential sensitivity (note 1)	S_{ts}	-	-53	-	dBm
Figure of merit (note 2)	M	50	-	-	
Video impedance (note 3)	Z_v	-	300	-	Ω
Voltage standing wave ratio (note 4)	v.s.w.r.	-	-	5:1	

Notes

1. Measured at 16.5 GHz in JAN201 holder, zero bias, video bandwidth = 1.0 MHz. BS9300, method 1411.
2. Measured at 16.5 GHz in JAN201 holder, M is taken as the product of the current sensitivity, expressed in μA per μW , and the square root of the video impedance in ohms. BS9300, method 1414.
3. Zero bias, input 1.0 mV max. (d.c. or a.c. r.m.s.). BS9300, method 1404.
4. With respect to $50\ \Omega$, measured at $f = 16.5\text{ GHz}$, zero bias and c.w. input power less than $1.0\ \mu\text{W}$.

MICROWAVE DETECTOR DIODES

Sub-miniature germanium backward diodes primarily intended for broadband low level detector applications in X-band. They conform to the environmental requirements of BS9300 where applicable.

QUICK REFERENCE DATA

Frequency range			1 to 18	GHz
Zero bias tangential sensitivity in X-band	AEY31	typ.	-53	dBm
	AEY31A	typ.	-50	dBm

This data must be read in conjunction with GENERAL SAFETY RECOMMENDATIONS – MICROWAVE SEMICONDUCTORS

MECHANICAL DATA

Dimensions in mm

Conforms to SOD-50

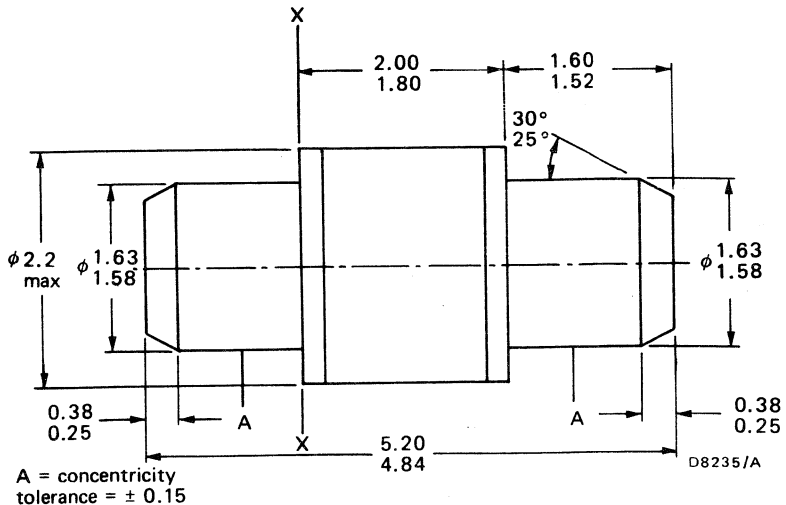

XX = reference plane

Terminal identification:

The AEY31 and AEY31A are colour coded as follows:

The positive end (cathode) is marked red and the negative end (anode) is marked blue.

The positive end indicates the electrode which becomes positive in an a.c. rectifier circuit.

RATINGS

Limiting values in accordance with the Absolute Maximum System (IEC134)

Storage temperature range	T_{stg}	-55 to +85	°C
Ambient temperature range	T_{amb}	-55 to +85	°C

CHARACTERISTICS ($T_{amb} = 25\text{ }^{\circ}\text{C}$)

			min.	typ.	max.	
→ Static						
Reverse current $V_R = 0.3\text{ V}$		I_R	-	12		mA
Forward current $V_F = 0.3\text{ V}$		I_F	-	100		μA
Dynamic						
Tangential sensitivity (note 1)	AEY31	S_{ts}	-	-53	-	dBm
	AEY31A	S_{ts}	-	-50	-	dBm
Figure of merit (note 2)	AEY31	M	100	-	-	
	AEY31A	M	50	-	-	
Video impedance (note 3)		Z_v	-	300	-	Ω
Voltage standing wave ratio (note 4)		v.s.w.r.	-	-	5:1	

Notes

1. Measured at 9.375 GHz, zero bias, video bandwidth = 1.0 MHz. BS9300, method 1411.
2. Measured at 9.375 GHz, M is taken as the product of current sensitivity, expressed in μA per μW , and the square root of video impedance in ohms. BS9300, method 1414.
3. Zero bias, input 1.0 mV max. (d.c. or a.c. r.m.s.). BS9300, method 1404.
4. With respect to $50\ \Omega$, measured at $f = 9.375\text{ GHz}$, zero bias and c.w. input power less than $1.0\ \mu\text{W}$. The nominal rectifier admittance at a reference plane X-X taken at the end faces of the ceramic insulator (see outline drawing on page 1) is:

$$(2.0 - j 2.0) \frac{1}{50} \text{ mho}$$

APPLICATION INFORMATION

1. Detector performance at other than Test Radio Frequency

			typ.	max.	
Tangential sensitivity, $f = 1.0$ to 18 GHz , $B = 1.0\text{ MHz}$,					
	AEY31	S_{ts}	-53	-	dBm
	AEY31A	S_{ts}	-50	-	dBm
Voltage standing wave ratio, $f = 1.0$ to 18 GHz , $Z_0 = 50\ \Omega$		v.s.w.r.	-	5:1	

2. Mixer performance (I.F. = 45 MHz)

Measured overall noise figure, $f = 9.375\text{ GHz}$, $N_{if} = 1.5\text{ dB}$, $P_{L.O.} = 200\ \mu\text{W}$, $I_{out} = 1.0\text{ mA}$		N_o	9.0		dB
$f = 16.5\text{ GHz}$, $N_{if} = 1.5\text{ dB}$, $P_{L.O.} = 200\ \mu\text{W}$, $I_{out} = 1.0\text{ mA}$			9.5	-	dB
I.F. impedance, $I_{out} = 1.0\text{ mA}$		Z_{if}	130	-	Ω
Voltage standing wave ratio, $f = 1$ to 18 GHz , $Z_0 = 50\ \Omega$, $I_{out} = 1.0\text{ mA}$			-	2.5:1	

3. Doppler mixer performance (i.f. = 3 kHz)

Measured overall noise figure, $f = 9.375\text{ GHz}$, $N_{if} = 2.0\text{ dB}$		N_o	18	-	dB
--	--	-------	----	---	----

MICROWAVE DETECTOR DIODE

Sub-miniature germanium backward diode primarily intended for broadband low level detector applications in Q-band (Ka-band). It conforms to the environmental requirements of BS9300 where applicable.

QUICK REFERENCE DATA

Frequency range			18 to 40	GHz
Zero bias current sensitivity in the band 18 to 40 GHz	S_i	typ.	2.0	$\mu A/\mu W$

This data must be read in conjunction with GENERAL SAFETY RECOMMENDATIONS – MICROWAVE SEMICONDUCTORS

MECHANICAL DATA

Dimensions in mm ←

Conforms to SOD-50

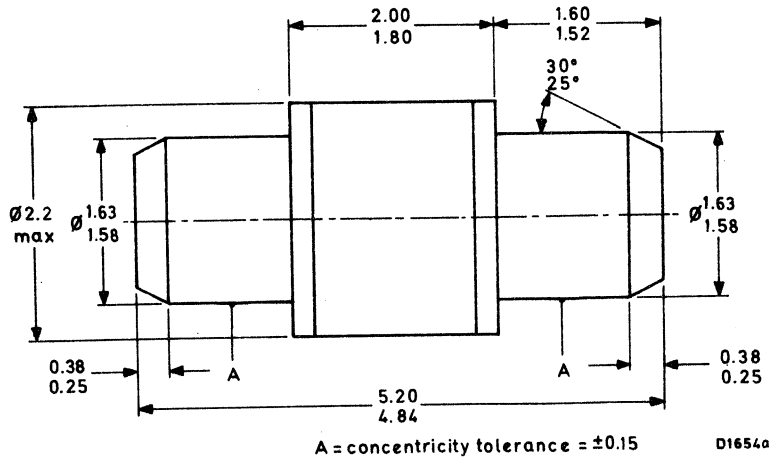

Terminal identification:

The AEY32 is colour coded as follows:

The positive end (cathode) is marked red and the negative end (anode) is marked blue.

The positive end indicates the electrode which becomes positive in an a.c. rectifier circuit.

→ RATINGS

Limiting values in accordance with the Absolute Maximum System (IEC134)

Storage temperature range	T_{stg}	-55 to +85	°C
Ambient temperature range	T_{amb}	-55 to +85	°C
Pulsed r.f. input power (f = 9.375 GHz, $t_p = 0.5 \mu s$, p.r.f. = 2000 p.p.s.)		max. 40	mW

CHARACTERISTICS ($T_{amb} = 25 \text{ }^\circ\text{C}$)

		min.	typ.	max.	
1/f noise (note 1)		-	-	7.0	dB
Swept v.s.w.r. (26.5 to 40 GHz) (note 2)		-	-	5:1	
Video impedance (note 3)	Z_v	3.0	-	5.0	k Ω
Current sensitivity (note 4)	S_i	-	2.0	-	$\mu A/\mu W$
Figure of merit (note 5)	M	50	-	-	

Notes

1. Measured at an i.f. of 1 kHz with 50 Hz bandwidth and zero bias.
2. Measured in a Q-band broadband mount (specification 7313-731-0091).
The v.s.w.r. measurement is swept over the band 26.5 to 40 GHz at a power level not exceeding 100 μW and with zero bias.
3. Measured at an i.f. of 1.6 kHz with an input not exceeding 1 mV and with zero bias.
4. Measured in the same mount as described in note 2 at frequencies of 27 GHz, 34 GHz and 40 GHz, with an input power not exceeding 1 μW and with zero bias. Rectified current measured by a microammeter of resistance less than 10 Ω .
5. Measured at frequencies of 27 GHz, 34 GHz and 40 GHz. M is the product of current sensitivity expressed in $\mu A/\mu W$ and square root of the video impedance expressed in ohms.

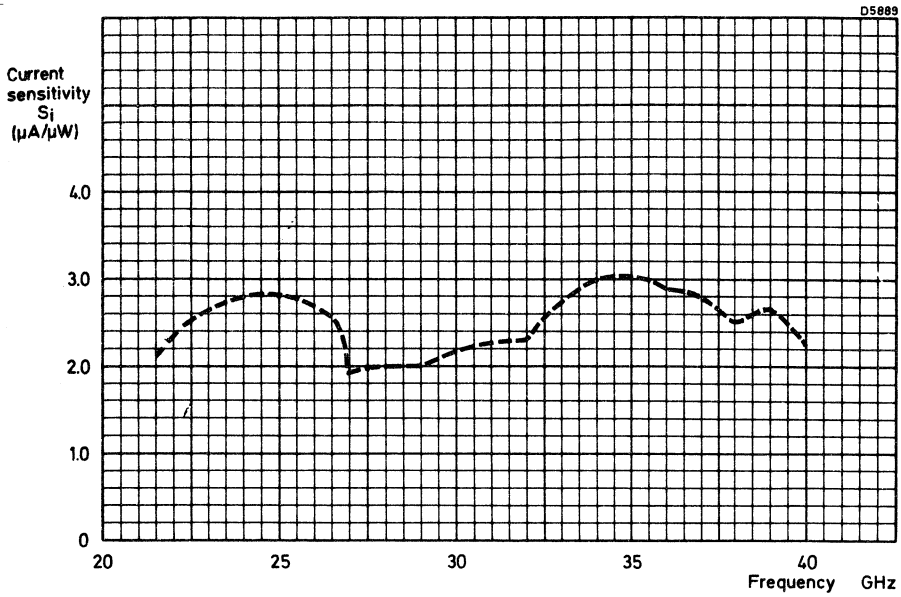

Typical current sensitivity as a function of frequency

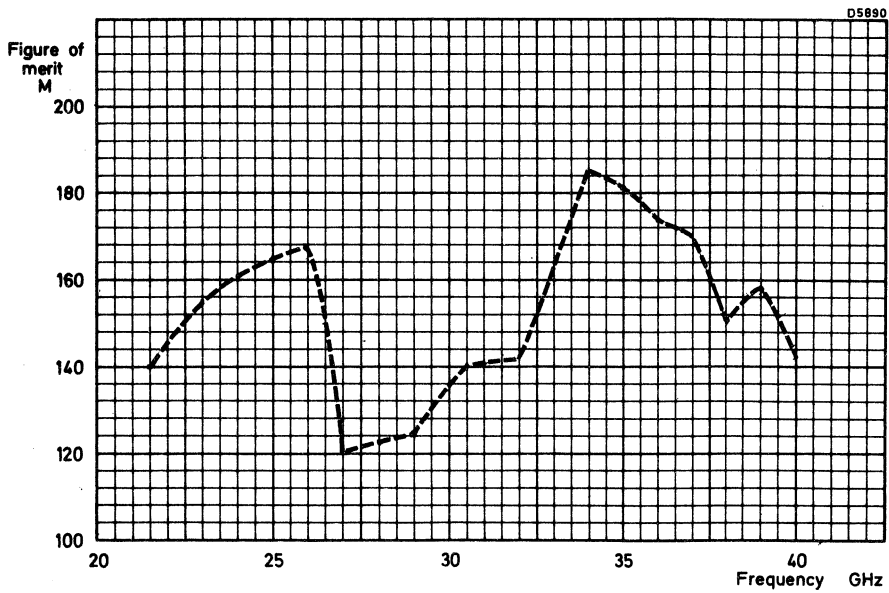

Typical figure of merit as a function of frequency

MICROWAVE DETECTOR DIODE

Germanium backward diode primarily intended for low level detector applications in J-band (Ku-band). It is packaged in the standard coaxial outline for this frequency band, similar to 1N78 types. The encapsulation is hermetically sealed and is cadmium plated. The AEY33 conforms to the environmental requirements of BS9300 where applicable.

QUICK REFERENCE DATA

Frequency range		12 to 18	GHz
Zero bias tangential sensitivity in J-band	typ.	-53	dBm

This data must be read in conjunction with GENERAL SAFETY RECOMMENDATIONS – MICROWAVE SEMICONDUCTORS

MECHANICAL DATA

Dimensions in mm

Conforms to SOD-49

Similar to JEDEC DO-37

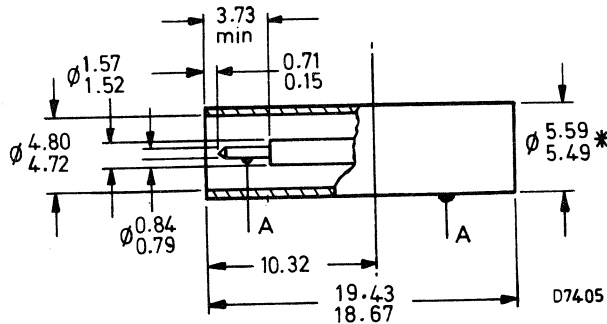

A = concentricity tolerance = ± 0.35

*These limits apply only to the 10.32 dimension

Terminal identification:

Pin	cathode
Body	anode

RATINGS

Limiting values in accordance with the Absolute Maximum System (IEC134)

Storage temperature range	T_{stg}	-55 to +100	°C
Ambient temperature range	T_{amb}	-55 to +100	°C

CHARACTERISTICS ($T_{amb} = 25\text{ °C}$)

		min.	typ.	max.	
Static					
Reverse current $V_R = 0.3\text{ V}$	I_R	—	9	—	mA
Forward current $V_F = 0.3\text{ V}$	I_F	—	130	—	μA
Dynamic					
Tangential sensitivity (note 1)	S_{ts}	—	-53	—	dBm
Figure of merit (note 2)	M	50	—	—	
Video impedance (note 3)	Z_v	250	—	400	Ω
Voltage standing wave ratio (note 4)	v.s.w.r.	—	—	5:1	
Current sensitivity (note 5)	S_i	3.2	5.0	—	

Notes

1. Measured at 16.5 GHz in JAN201 holder, zero bias, video bandwidth = 1.0 MHz. BS9300, method 1411.
2. Measured at 16.5 GHz in JAN201 holder, M is taken as the product of the current sensitivity, expressed in μA per μW , and the square root of the video impedance in ohms. BS9300, method 1414.
3. Zero bias, input 1.0 mV. (d.c. or a.c. r.m.s.).
4. With respect to $50\ \Omega$, measured at $f = 16.5\text{ GHz}$, zero bias and c.w. input power less than $1.0\ \mu\text{W}$.
5. Measured at 16.5 GHz in a JAN201 holder with zero bias and an input power of $1.0\ \mu\text{W}$. BS9300, method 1412.

MULTIPLIER VARACTOR DIODES



≡ E

SILICON MULTIPLIER VARACTOR DIODE

Silicon planar epitaxial varactor diode for use as a high efficiency frequency multiplier in the v.h.f. and u.h.f. bands. As a tripler from 150 to 450 MHz it has a typical efficiency of 64% and can handle inputs up to 40 W. The BAY96 has a very low series resistance and is packaged in a low inductance, hermetically sealed, welded ceramic-metal envelope with stud cathode. It conforms to the environmental requirements of BS9300 where applicable.

QUICK REFERENCE DATA

D.C. reverse voltage	V_R	max.	120	V
Total power dissipation	P_{tot}	max.	20	W
Junction temperature	T_j	max.	175	°C
Total capacitance ($V_R = 6.0$ V, $f = 1.0$ MHz)	C_T		28 to 39	pF
Series resistance ($V_R = 6.0$ V, $f = 400$ MHz)	r_s	max.	1.2	Ω
Cut-off frequency $\frac{1}{2\pi r_s C_T}$ at $V_R = 120$ V	f_{co}	typ.	25	GHz

This data must be read in conjunction with GENERAL SAFETY RECOMMENDATIONS – MICROWAVE SEMICONDUCTORS

MECHANICAL DATA

Dimensions in mm

Conforms to SOD-4/8
 Conforms to BS3934 SO-10
 Similar to JEDEC DO-4

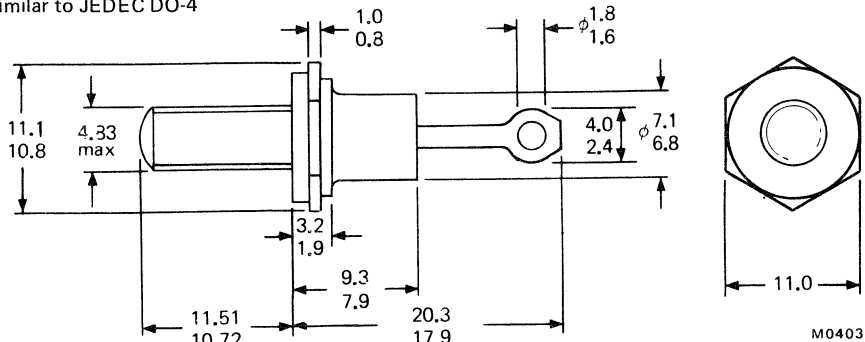

Diameter of clearance hole: max. 5.2

Torque on nut: min. 0.9 Nm
 max. 1.7 Nm

Accessories supplied on request:

- 56295 (PTFE bush, 2 mica washers, plain washer, tag)
- 56262A (mica washer, insulating ring, plain washer)

Supplied with device: 1 nut, 1 lock washer

Nut dimensions across the flats: 9.5

RATINGS

Limiting values in accordance with the Absolute Maximum System (IEC134)

Storage temperature range	T_{stg}		-65 to +175	°C
Junction temperature (operating)	T_j	max.	175	°C
D.C. reverse voltage	V_R	max.	120	V
Total power dissipation ($T_{mb} = 25\text{ °C}$)	P_{tot}	max.	20	W

THERMAL RESISTANCE

Thermal resistance from junction to mounting base	$R_{th\ j-mb}$		7.5	°C/W
---	----------------	--	-----	------

CHARACTERISTICS

		min.	typ.	max.	
Total capacitance $V_R = 6.0\text{ V}, f = 1.0\text{ MHz}$	C_T	28	—	39	pF
Series resistance $V_R = 6.0\text{ V}, f = 400\text{ MHz}$	r_s	—	0.9	1.2	Ω
Cut-off frequency $\frac{1}{2\pi r_s C_T}$ at $V_R = 120\text{ V}$	f_{co}	—	25	—	GHz



APPLICATION INFORMATION

Typical operating characteristics as a frequency tripler

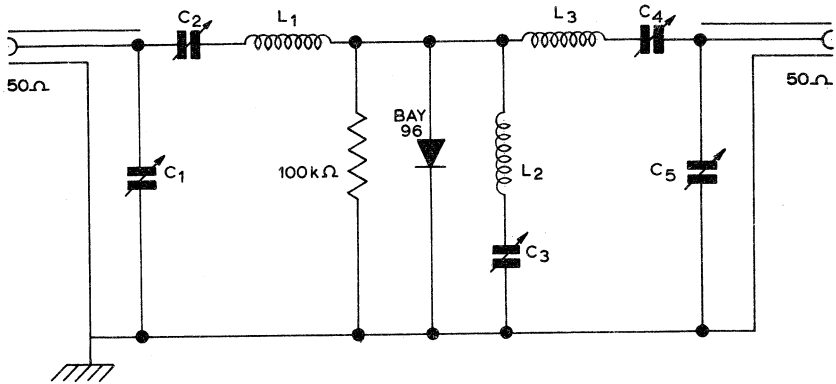

Frequency tripler circuit – 150 to 450 MHz

L_1 = 6.5 turns 18 s.w.g. wire, 0.297" I.D., 0.562" long

L_2 = 2 turns 14 s.w.g. wire, 0.266" I.D., 0.312" long

L_3 = 1.0" × 0.25" × 0.020" copper strip, 0.562" from chassis

C_1 = 7.0 to 100 pF variable

C_2, C_3, C_4 = 2.0 to 13 pF variable

C_5 = 2.0 to 25 pF variable

Efficiency

$P_{in} = 25 \text{ W}, f_{in} = 150 \text{ MHz}$

η	min.	60	%
	typ.	64	%

APPLICATION INFORMATION (continued)

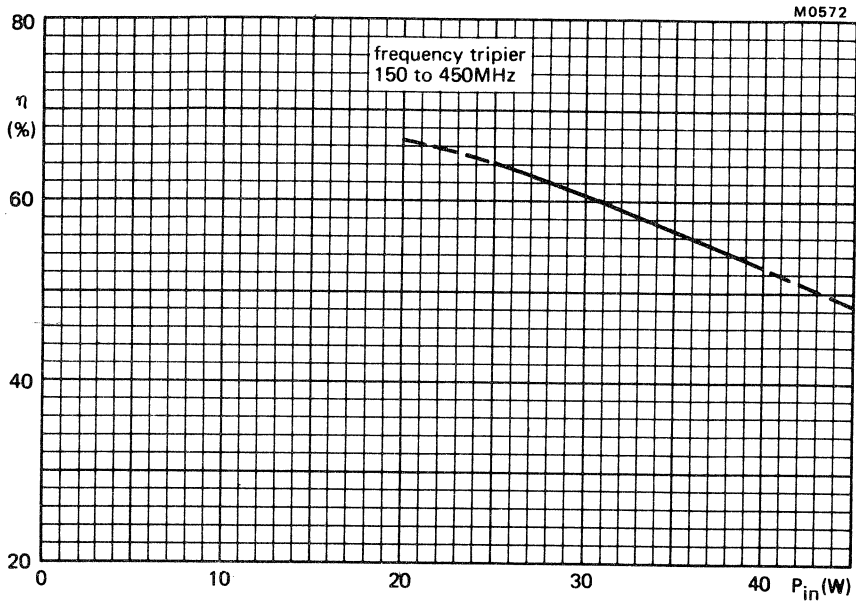

Typical tripler efficiency as a function of input power
See circuit on page 3

B5649

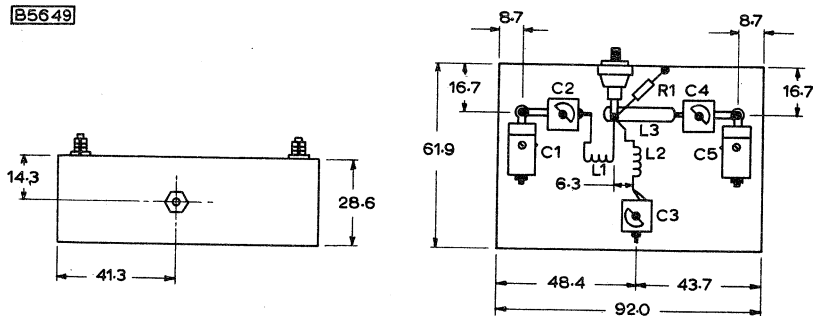

Component layout of tripler circuit

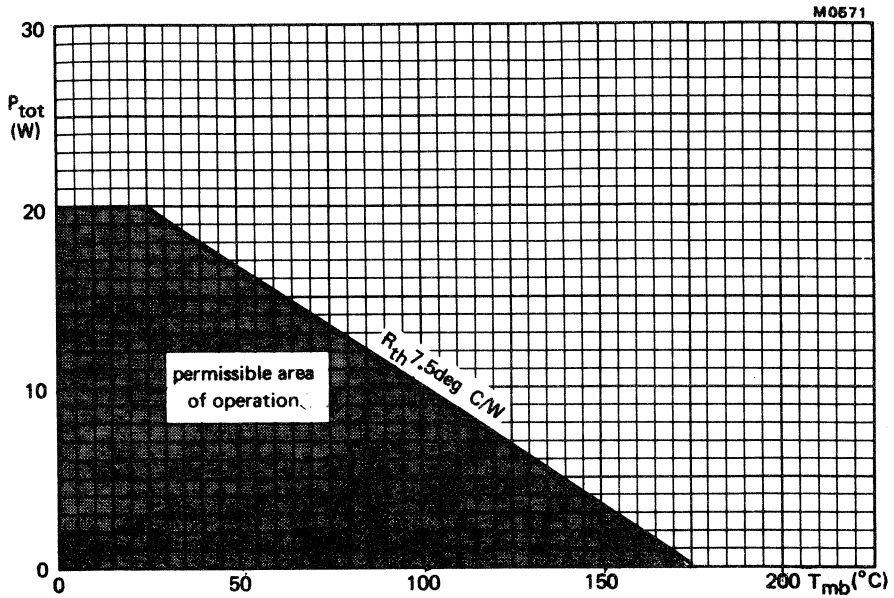

Typical dissipation as a function of mounting base temperature

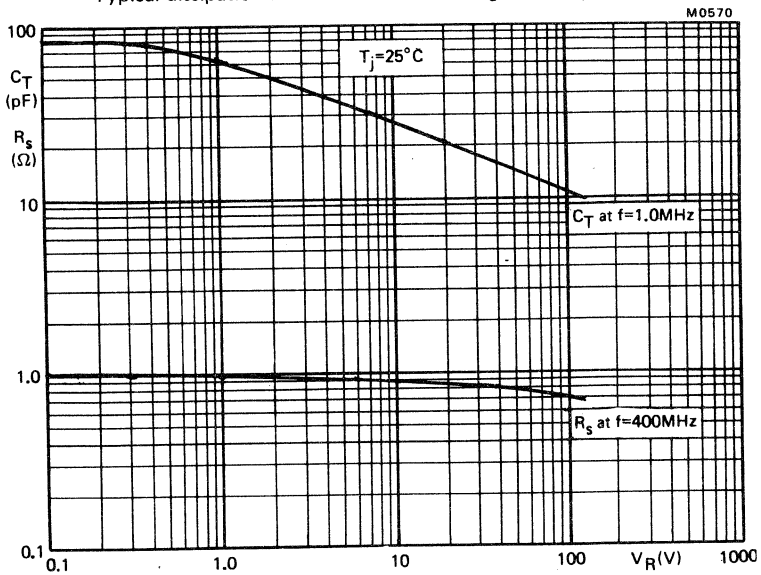

Typical diode capacitance and series resistance as a function of reverse voltage

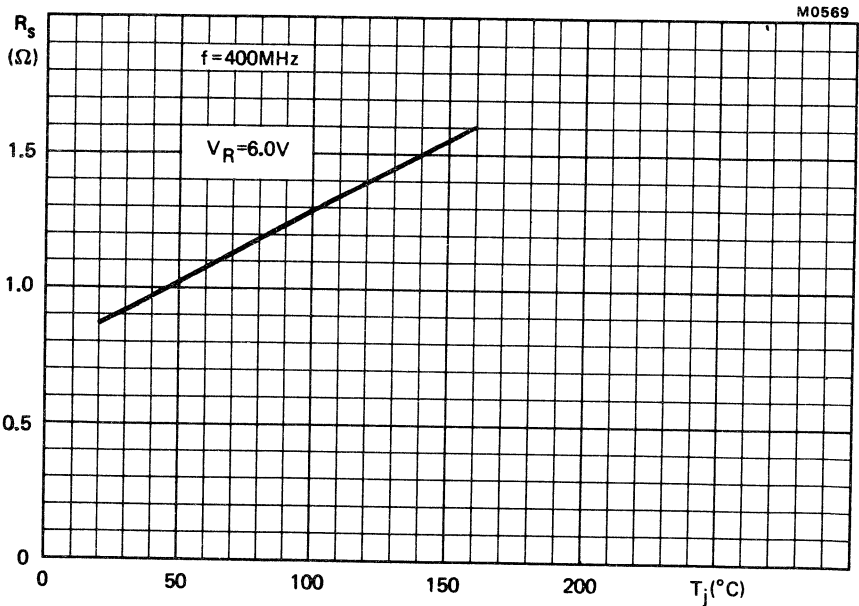
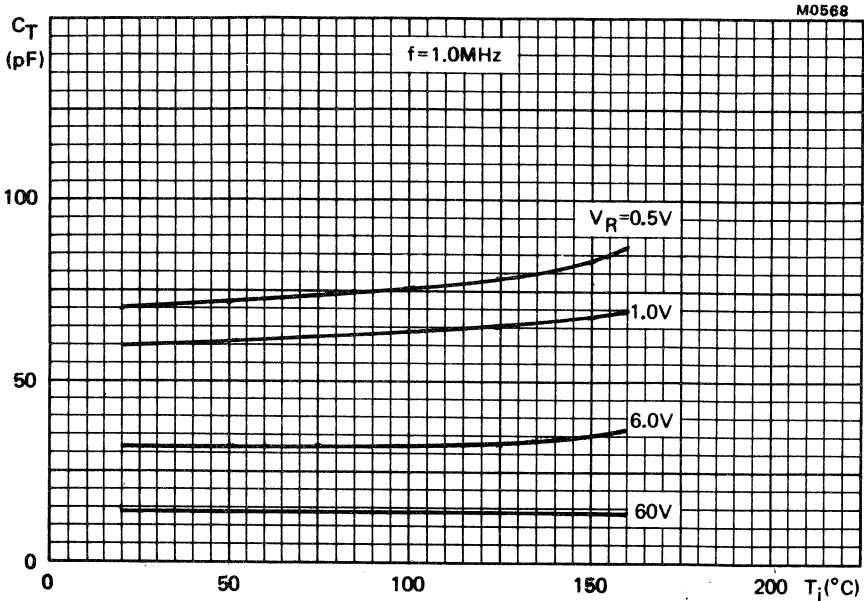

Typical diode capacitance and series resistance
as a function of junction temperature

STEP RECOVERY DIODE

Silicon planar epitaxial varactor diode exhibiting step recovery characteristics, especially suitable for use in frequency multiplier circuits up to S-band output frequency. It is a diffused silicon device and is mounted in a small double-ended ceramic-metal case with hermetic seal and conforms to the environmental requirements of BS9300 where applicable.

QUICK REFERENCE DATA

Operation as a frequency doubler 1 to 2 GHz in a typical circuit,

Input r.f. power	P_{in}		10	W
Output r.f. power	P_{out}		5.0	W
Resistive cut-off frequency	f_{co}	typ.	100	GHz
$V_R = 6.0$ V				
Total capacitance	C_T	typ.	4.5	pF
$V_R = 6.0$ V				
Junction temperature	T_j	max.	150	°C

This data must be read in conjunction with GENERAL SAFETY RECOMMENDATIONS – MICROWAVE SEMICONDUCTORS

MECHANICAL DATA

Dimensions in mm

Conforms to SOD-31

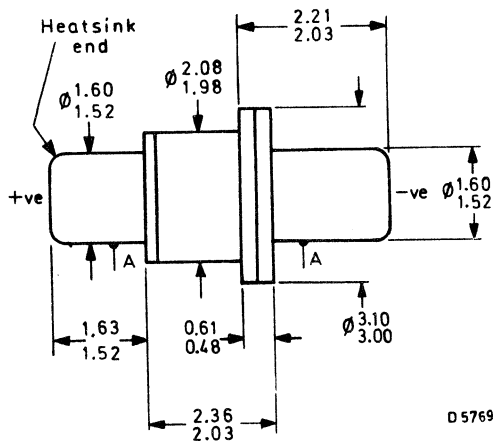

A = concentricity tolerance = ± 0.13

Chips from this range of devices may be supplied in alternative packages to customers' requirements.

RATINGS

Limiting values in accordance with the Absolute Maximum System (IEC134)

Storage temperature range	T_{stg}		-55 to +150	°C
Junction temperature	T_j	max.	150	°C
D.C. reverse voltage	V_R	max.	55	V
Total power dissipation R.F.	P_{tot}	max.	4.0	W
$T_{pin} \leq 70$ °C				
$T_{pin} > 70$ °C, derating factor			50	mW/°C

THERMAL RESISTANCE

Thermal resistance from junction to pin	$R_{th\ j-pin}$	max.	20	°C/W
---	-----------------	------	----	------

CHARACTERISTICS ($T_{amb} = 25$ °C)

		min.	typ.	max.	
Reverse breakdown voltage	$V_{(BR)R}$	55	70	—	V
Reverse current, $V_R = 6.0$ V	I_R	—	0.001	1.0	μA
Cut-off frequency, $V_R = 6.0$ V	f_{co}	50	100	—	GHz
$\frac{1}{2\pi r_s C_j}$					
Total capacitance ($C_j + C_s$) $V_R = 6.0$ V, $f = 1.0$ MHz	C_T	3.0	4.5	6.0	pF
Stray capacitance	C_s	—	0.25	—	pF
Series inductance	L_s	—	650	—	pH
Series resistance, $V_R = 6.0$ V	r_s	—	0.4	—	Ω
Overall efficiency					
$P_{in} = 10$ W, $f_{in} = 1.0$ GHz					
frequency doubler	η	50	60	—	%
frequency trebler	η	—	40	—	%

APPLICATION INFORMATION

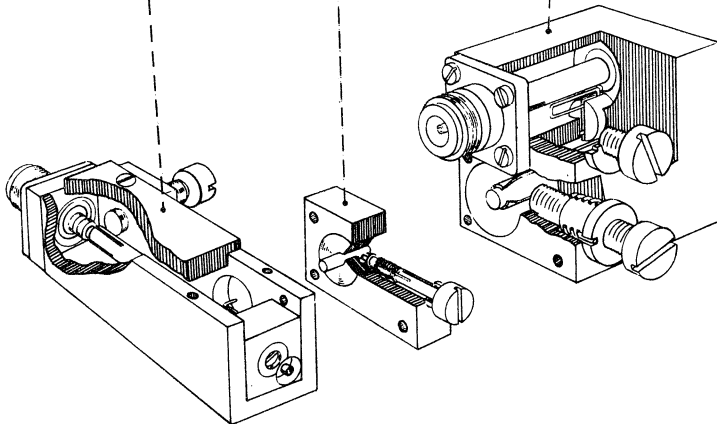
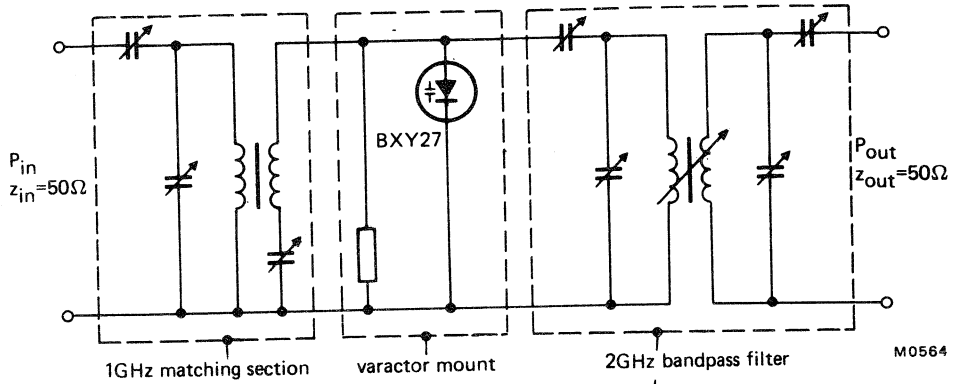

Frequency doubler circuit (1 to 2 GHz)

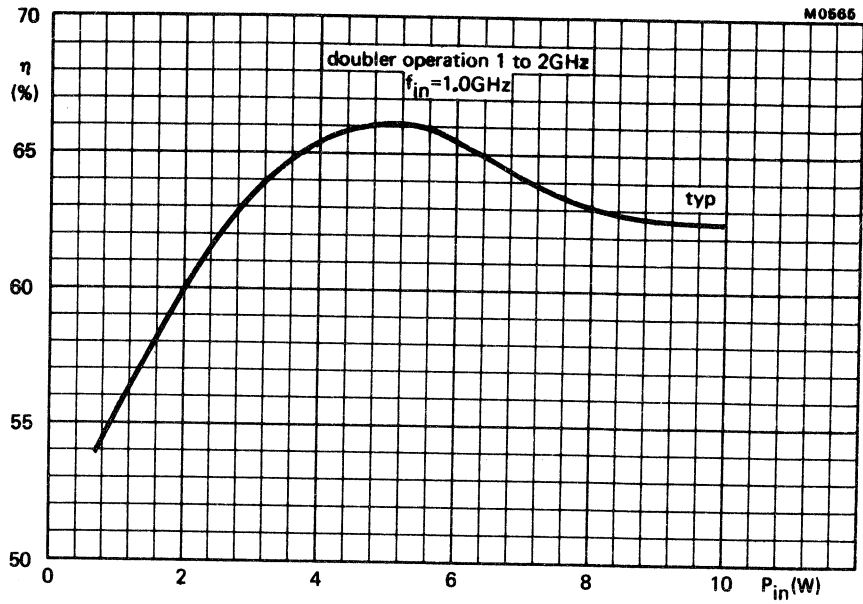

Overall efficiency as a function of input power
for doubler operation

STEP RECOVERY DIODE

Silicon planar epitaxial varactor diode exhibiting step recovery characteristics, especially suitable for use in frequency multiplier circuits up to C-band output frequency. It is a diffused silicon device and is mounted in a small double-ended ceramic-metal case with hermetic seal and conforms to the environmental requirements of BS9300 where applicable.

QUICK REFERENCE DATA

Operation as a frequency doubler 2 to 4 GHz in a typical circuit.

Input r.f. power	P_{in}		7.0	W
Output r.f. power	P_{out}		3.5	W
Resistive cut-off frequency, $V_R = 6.0$ V	f_{co}	typ.	120	GHz
Total capacitance, $V_R = 6.0$ V	C_T	typ.	1.5	pF
Junction temperature	T_j	max.	150	°C

This data must be read in conjunction with GENERAL SAFETY RECOMMENDATIONS – MICROWAVE SEMICONDUCTORS

MECHANICAL DATA

Dimensions in mm

Conforms to SOD-31

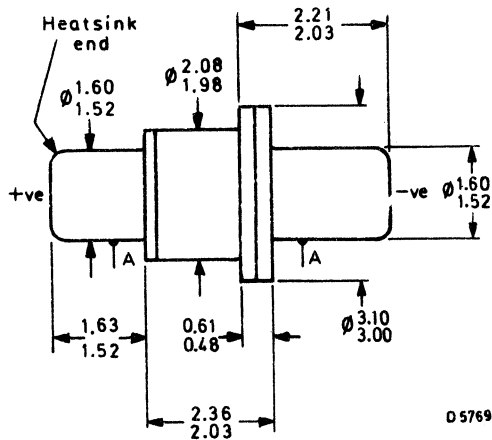

A = concentricity tolerance = ± 0.13

Chips from this range of devices may be supplied in alternative packages to customers' requirements.

RATINGS

Limiting values in accordance with the Absolute Maximum System (IEC134)

Storage temperature range	T_{stg}		-55 to +150	°C
Junction temperature	T_j	max.	150	°C
D.C. reverse voltage	V_R	max.	45	V
Total power dissipation R.F.	P_{tot}	max.	2.7	W
$T_{pin} \leq 70\text{ °C}$			34	mW/°C
$T_{pin} > 70\text{ °C}$, derating factor				

THERMAL RESISTANCE

Thermal resistance from junction to pin	$R_{th\ j-pin}$	max.	30	°C/W
---	-----------------	------	----	------

CHARACTERISTICS ($T_{amb} = 25\text{ °C}$)

Reverse breakdown voltage	$V_{(BR)R}$	min.	typ.	max.	
Reverse current, $V_R = 6.0\text{ V}$		45	60	—	V
Cut-off frequency, $V_R = 6.0\text{ V}$	I_R	—	0.001	1.0	μA
$\frac{1}{2\pi r_s C_j}$					
Total capacitance ($C_j + C_s$) $V_R = 6.0\text{ V}$, $f = 1.0\text{ MHz}$	C_T	1.0	1.5	2.5	pF
Stray capacitance	C_s	—	0.25	—	pF
Series inductance	L_s	—	650	—	pH
Series resistance, $V_R = 6.0\text{ V}$	r_s	—	1.0	—	Ω
Overall efficiency $P_{in} = 7.0\text{ W}$, $f_{in} = 2.0\text{ GHz}$ frequency doubler	η	50	—	—	%

APPLICATION INFORMATION

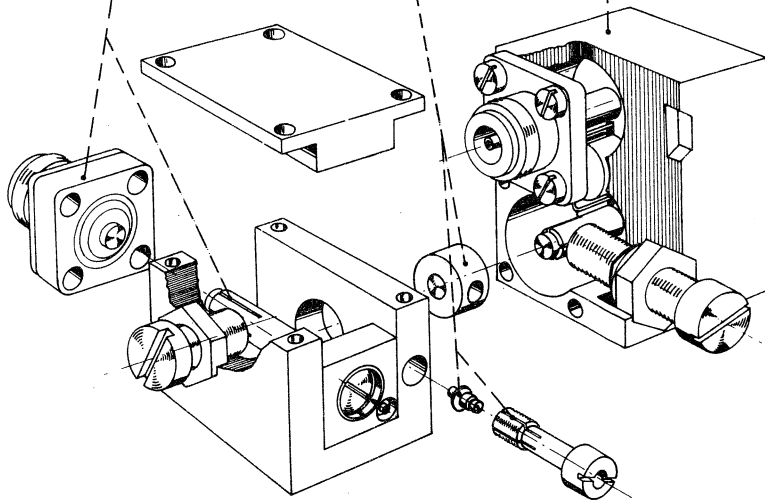
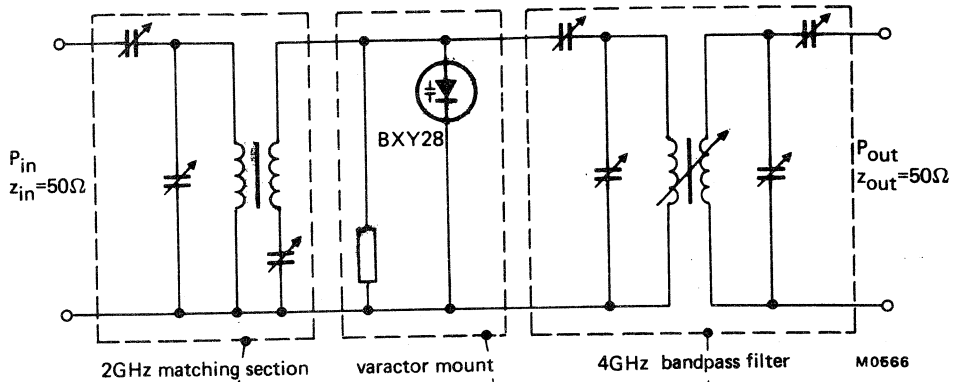

Frequency doubler circuit (2 to 4 GHz)

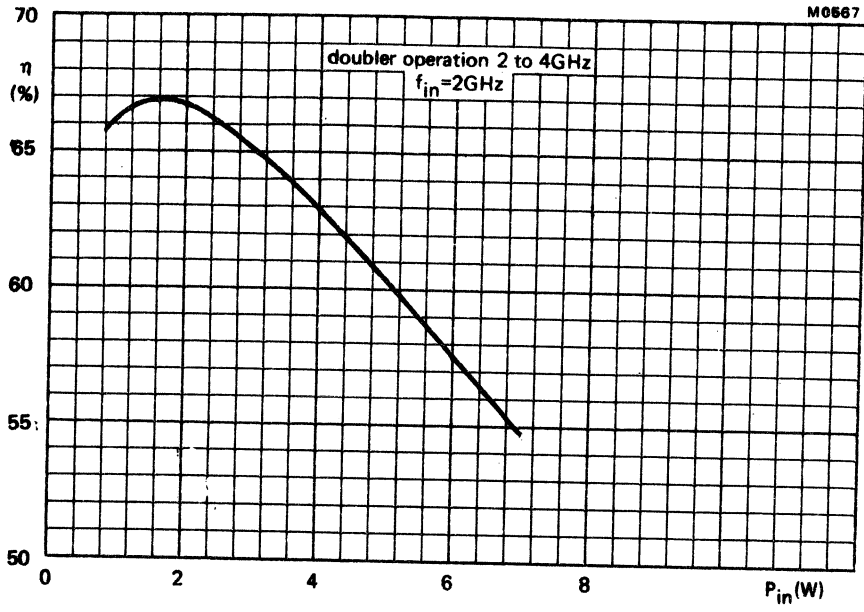

Overall efficiency as a function of input power for doubler operation

STEP RECOVERY DIODE

Silicon planar epitaxial varactor diode exhibiting step recovery characteristics, especially suitable for high order frequency multiplier circuits up to X-band output frequency. It is a diffused silicon device and is mounted in a small double-ended ceramic-metal case with hermetic seal and conforms to the environmental requirements of BS9300 where applicable.

QUICK REFERENCE DATA

Operation as a frequency quadrupler 2.25 to 9.0 GHz in a typical circuit.

Input r.f. power	P_{in}		1.0	W
Output r.f. power	P_{out}		0.3	W
Resistive cut-off frequency $V_R = 6.0$ V	f_{co}	typ.	120	GHz
Total capacitance $V_R = 6.0$ V	C_T	typ.	1.0	pF
Junction temperature	T_j	max.	150	$^{\circ}C$

This data must be read in conjunction with GENERAL SAFETY RECOMMENDATIONS – MICROWAVE SEMICONDUCTORS

MECHANICAL DATA

Conforms to SOD-31

Dimensions in mm

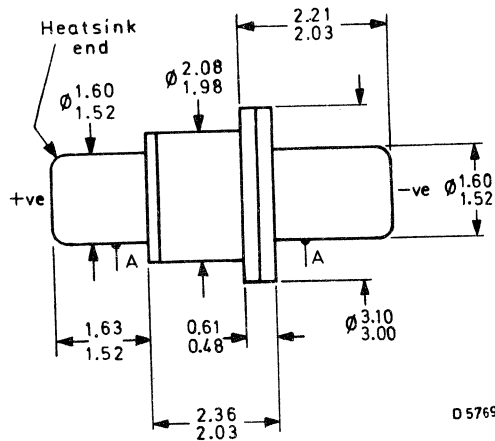

D 5769

-A= concentricity tolerance = ± 0.13

Chips from this range of devices may be supplied in alternative packages to customers' requirements.

RATINGS

Limiting values in accordance with the Absolute Maximum System (IEC134)

Storage temperature range			-55 to +150	°C
Junction temperature	T_j	max.	150	°C
D.C. reverse voltage	V_R	max.	25	V
Total power dissipation R.F. $T_{pin} \leq 70$ °C	P_{tot}	max.	2.0	W

THERMAL RESISTANCE

Thermal resistance from junction to pin	$R_{th\ j-pin}$	max.	40	°C/W
---	-----------------	------	----	------

CHARACTERISTICS ($T_{amb} = 25$ °C)

		min.	typ.	max.	
Reverse breakdown voltage $I_R = 1.0$ mA	$V_{(BR)R}$	25	—	—	V
Reverse current, $V_R = 6.0$ V	I_R	—	0.001	1.0	μA
Cut-off frequency, $V_R = 6.0$ V (note 1)	f_{co}	90	120	—	GHz
Total capacitance ($C_j + C_s$) $V_R = 6.0$ V, $f = 1.0$ MHz	C_T	0.8	1.0	1.5	pF
Stray capacitance	C_s	—	0.25	—	pF
Series inductance	L_s	—	650	—	pH
Overall efficiency $P_{in} = 1.0$ W, $f_{in} = 2.25$ GHz frequency quadrupler	η	30	—	—	%

Notes

- The cut-off frequency f_{co} is defined as:
$$f_{co} = \frac{1}{2\pi r_s C_j}$$
 where C_j is the junction capacitance and is measured at 1.0 MHz, r_s is measured on a slotted line at 2.0 GHz.

S-X band quadrupler

B9937

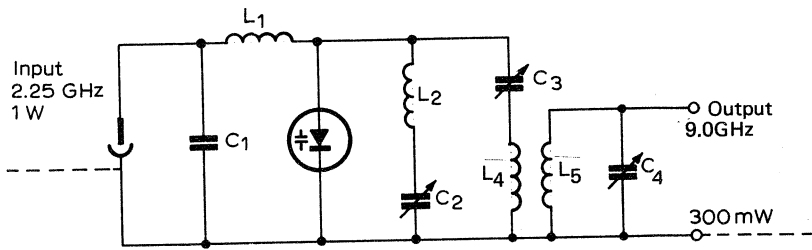
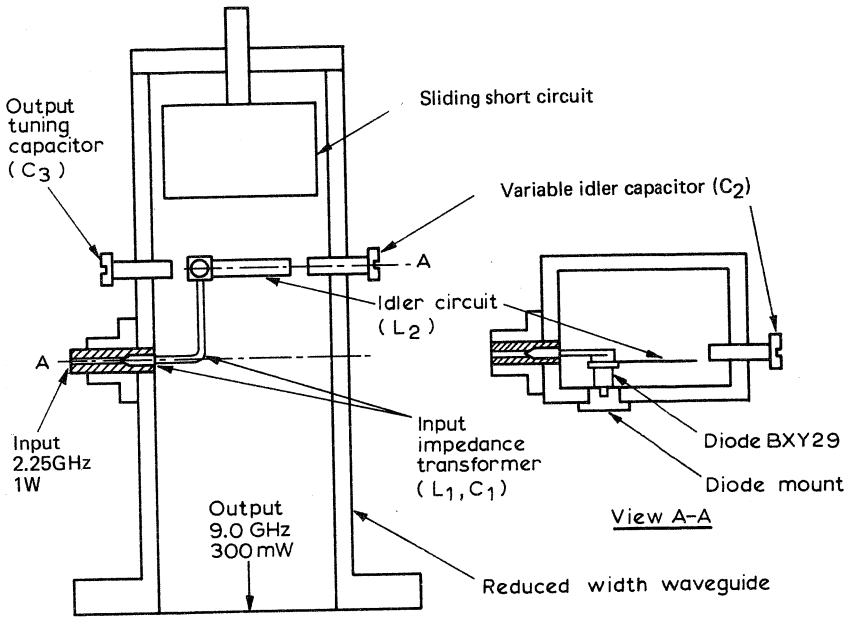

Approximate equivalent circuit

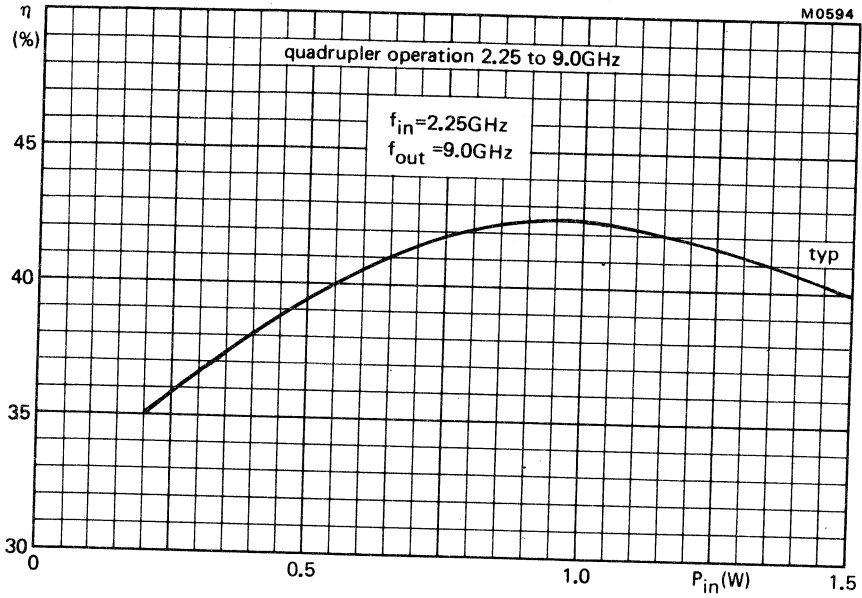

Overall efficiency as a function of input power
for quadrupler operation

STEP RECOVERY DIODE

Silicon planar epitaxial varactor diode exhibiting step recovery characteristics, especially suitable for high order frequency multiplier circuits up to X-band output frequency. It is a diffused silicon device and is mounted in a small double-ended ceramic-metal case with hermetic seal and conforms to the environmental requirements of BS9300 where applicable.

QUICK REFERENCE DATA

Operation as a high order frequency multiplier 1.0 to 10 GHz in a typical circuit.

Input r.f. power	P_{in}		500	mW
Output r.f. power	P_{out}		20	mW
Resistive cut-off frequency	f_{co}	typ.	150	GHz
$V_R = 6.0$ V				
Total capacitance	C_T	typ.	0.75	pF
$V_R = 6.0$ V				
Junction temperature	T_j	max.	150	°C

This data must be read in conjunction with GENERAL SAFETY RECOMMENDATIONS – MICROWAVE SEMICONDUCTORS

MECHANICAL DATA

Dimensions in mm

Conforms to SOD-31

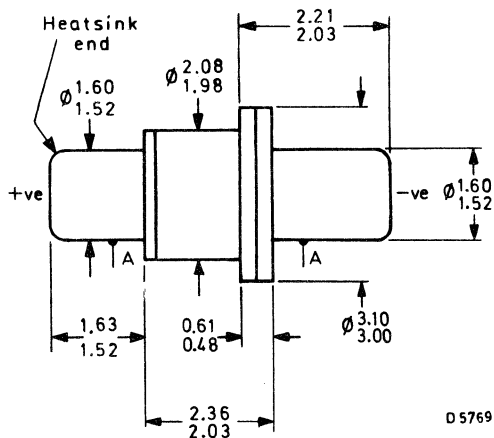

A = concentricity tolerance = ± 0.13

Chips from this range of devices may be supplied in alternative packages to customers' requirements.

RATINGS

Limiting values in accordance with the Absolute Maximum System (IEC134)

Storage temperature range	T_{stg}		-55 to +150	°C
Junction temperature	T_j	max.	150	°C
D.C. reverse voltage	V_R	max.	20	V
Total power dissipation R.F. $T_{pin} \leq 70$ °C	P_{tot}	max.	1.6	W

THERMAL RESISTANCE

Thermal resistance from junction to pin	$R_{th\ j-pin}$	max.	50	°C/W
---	-----------------	------	----	------

CHARACTERISTICS ($T_{amb} = 25$ °C)

		min.	typ.	max.	
Reverse breakdown voltage $I_R = 1.0$ mA	$V_{(BR)R}$	20	—	—	V
Reverse current, $V_R = 6.0$ V	I_R	—	0.001	1.0	μA
Cut-off frequency, $V_R = 6.0$ V (note 1)	f_{co}	100	150	—	GHz
Total capacitance ($C_j + C_s$) $V_R = 6.0$ V, $f = 1.0$ MHz	C_T	0.5	0.75	1.0	pF
Stray capacitance	C_s	—	0.25	—	pF
Series inductance	L_s	—	625	—	pH
Transition time	t_{tr}	—	—	150	ps
Storage time	t_s	—	50	—	ns

Notes

- The cut-off frequency f_{co} is defined as: $f_{co} = \frac{1}{2\pi r_s C_j}$

where C_j is the junction capacitance and is measured at 1.0 MHz,
 r_s is measured on a slotted line at 8.0 GHz

MULTIPLIER PERFORMANCE

		min.	typ.	max.	
Power output, $f_{in} = 1.0$ GHz $P_{in} = 500$ mW, $f_{out} = 10$ GHz	P_{out}	15	20	—	mW

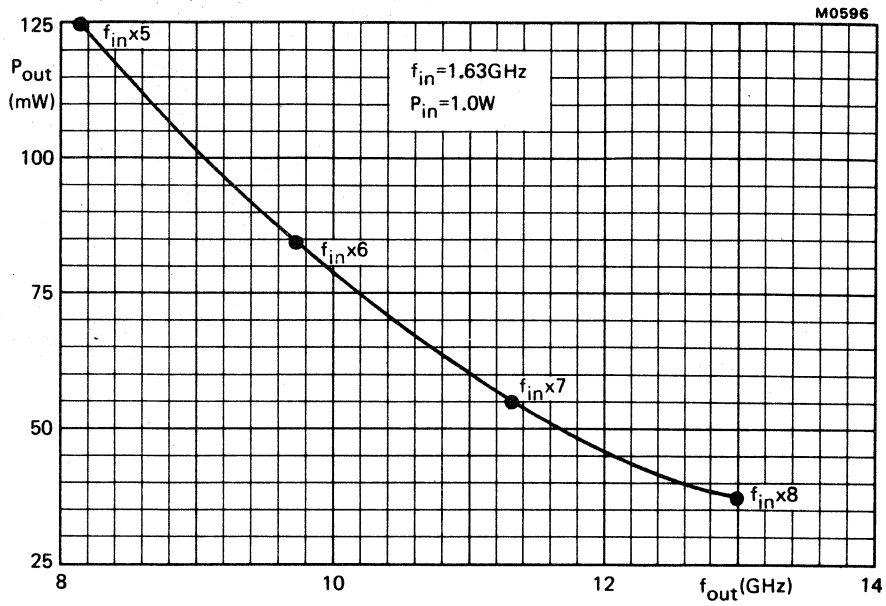

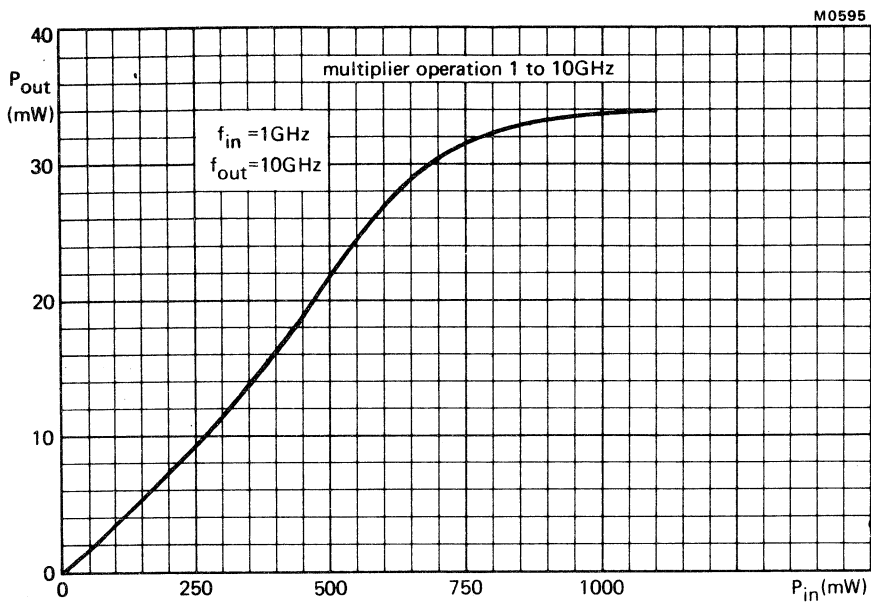

Typical performance as a frequency multiplier

STEP RECOVERY DIODES

Silicon planar varactor diodes exhibiting step recovery characteristics, especially suitable for use in frequency multipliers. They conform to the environmental requirements of BS9300 where applicable.

This data must be read in conjunction with GENERAL SAFETY RECOMMENDATIONS – MICROWAVE SEMICONDUCTORS

			BXY35	BXY36	BXY37	BXY38	BXY39	BXY40	BXY41	
Reverse breakdown voltage	$V_{(BR)R}$	min.	100	70	70	50	40	25	25	V
$I_R = 10 \mu A$										
Cut-off frequency	f_{co}	min.	25	75	100	120	150	180	200	GHz
$V_R = 6.0 V$										
Diode capacitance	C_j	min.	6.0	4.0	2.0	1.2	0.8	0.4	0.25	pF
$V_R = 6.0 V$		max.	12	6.0	4.0	2.0	1.2	0.9	0.5	pF
Transition time	t_{tr}	max.	—	500	350	300	200	150	100	ps
Storage time	t_s	typ.	—	150	100	75	50	50	25	ns
Thermal resistance, junction to mounting base, types A,D,E	$R_{th j-mb}$		10	20	20	30	40	50	50	°C/W
Thermal resistance junction to pin, types B,C	$R_{th j-pin}$		10	20	20	30	40	50	50	°C/W
Multiplier performance										
Typical output frequency range		min.	0.75	2	4	6	7	8	10	GHz
		max.	2	4	6	8	9	10	14	GHz
Outlines available			A	—	—	—	—	—	—	
			—	B	B	B	B	B	B	
			—	C	C	C	C	C	C	
			—	D	D	D	D	D	D	
			—	E	E	E	E	E	E	

Devices may be selected from this range to suit customers' specific requirements, including further alternative packages.

MECHANICAL DATA

Dimensions in mm

Outline A Conforms to SOD-4/8 and BS3934 SO-10

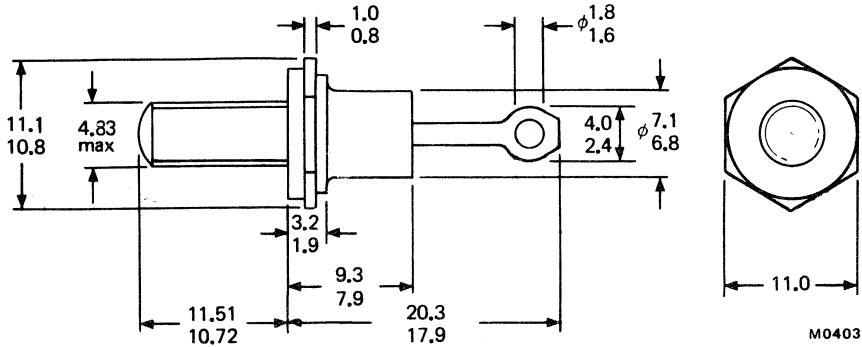

Diameter of clearance hole: 5.2

Torque on nut: min. 0.9 Nm
 max. 1.7 Nm

Accessories supplied on request:

56295 (PTFE bush, 2 mica washers, plain washer, tag)

56262A (mica washer, insulating ring, plain washer)

Supplied with device: 1 nut, 1 lock washer

Nut dimensions across the flats: 9.5

Outline B Conforms to SOD-31

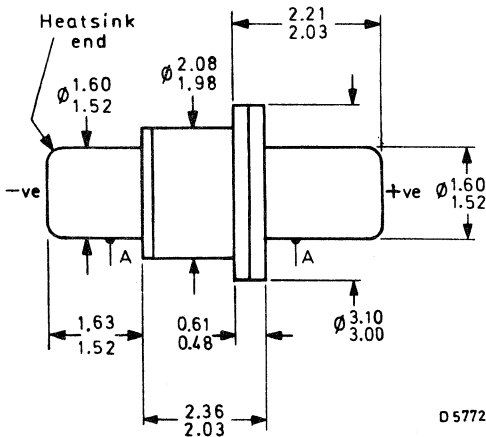

A = concentricity tolerance = ± 0.13

Outline C Conforms to SOD-73

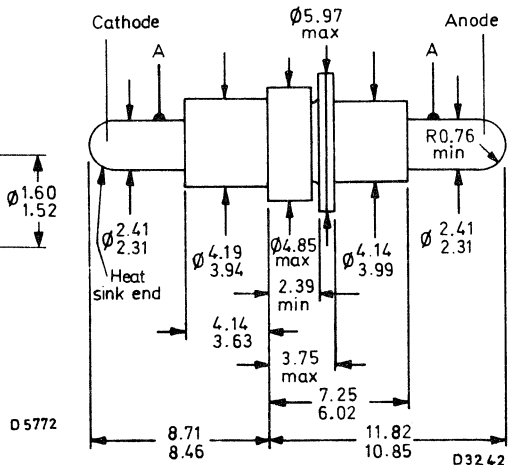

Outline D Conforms to SOD-44

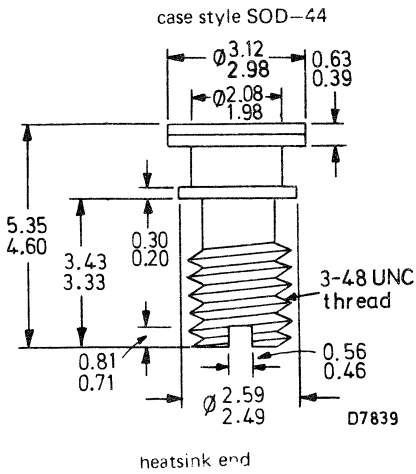

$C_S = 0.25\text{pF typ.}$
 $L_S = 0.65\text{nH typ.}$

Outline E Conforms to SOD-45

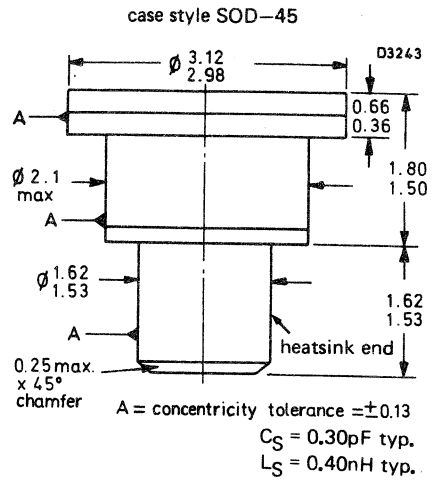

HIGH EFFICIENCY STEP RECOVERY DIODES

High efficiency silicon varactor diodes suitable for operation in low and high order multiplier circuits with output frequencies in the range 3 to 8 GHz. These diodes are of the diffused epitaxial type, having mesa construction for optimum performance and conform to the environmental requirements of BS9300 where applicable.

QUICK REFERENCE DATA

			BXY56	BXY57	
Reverse breakdown voltage $I_R = 10 \mu A$	$V_{(BR)R}$	min.	60	60	V
Junction capacitance $V_R = 6 V$	C_j	min.	1.5	2.5	pF
		max.	2.5	3.5	pF
Cut-off frequency $V_R = 6 V$	f_{co}	min.	160	140	GHz

Unless otherwise shown, data is applicable to both types.

This data must be read in conjunction with GENERAL SAFETY RECOMMENDATIONS – MICROWAVE SEMICONDUCTORS

MECHANICAL DATA

Dimensions in mm

Conforms to SOD-31 and BS3934 SO-86

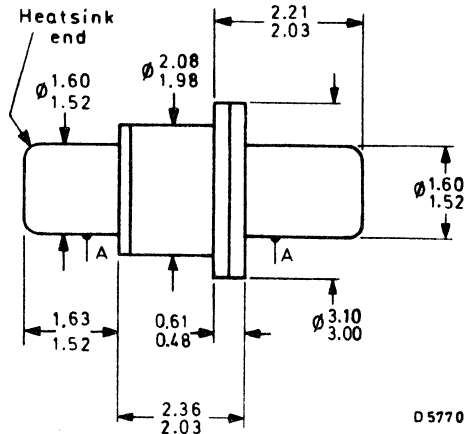

A = concentricity tolerance = ± 0.13

Normal operation with reverse bias, i.e. heatsink end positive.

Devices may be selected to suit customers' specific requirements, including alternative packages.

RATINGS

Limiting values in accordance with the Absolute Maximum System (IEC134)

			BXY56	BXY57	
Storage temperature range	T_{stg}		-55 to +175	-55 to +175	°C
Junction temperature	T_j	max.	175	175	°C
D.C. reverse voltage	V_R	max.	60	60	V
Total power dissipation					
T_{hs} max. 50 °C (note 1)	P_{tot}	max.	5.2	6.6	W

THERMAL RESISTANCE

Thermal resistance from junction to heatsink	$R_{th\ j-hs}$	max.	24	19	°C/W
--	----------------	------	----	----	------

CHARACTERISTICS ($T_{pin} = 25\text{ °C}$)

Reverse breakdown voltage					
$I_R = 10\ \mu A$	$V_{(BR)R}$	min.	60	60	V
Cut-off frequency					
$V_R = 6\text{ V}$ (note 2)	f_{co}	min.	160	140	GHz
Junction capacitance					
$V_R = 6\text{ V}, f = 1\text{ MHz}$	C_j	min.	1.5	2.5	pF
		max.	2.5	3.5	pF
Stray capacitance	C_s	typ.	0.25	0.25	pF
Series inductance	L_s	typ.	650	650	pH
Transition time	t_{tr}	typ.	150	200	ps
Lifetime	τ	typ.	60	150	ns

MULTIPLIER PERFORMANCE

(note 3)

Low order multiplier efficiency in a 2.1 to 4.2 GHz doubler	η	typ.	60	60	%
High order multiplier efficiency in a 0.45 to 3.6 GHz					
8x multiplier	η	typ.	20	20	%

Notes

- $P_{tot} = P_{in} - P_{out}$. Derating curves are sued for value of T_{hs} greater than 50 °C:—

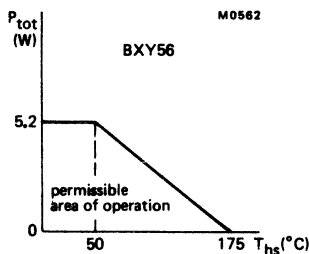

Fig. 1

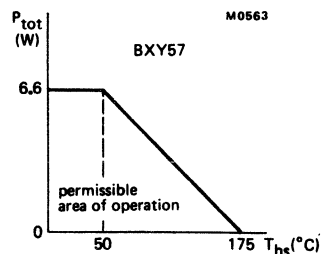

Fig. 2

Notes (continued)

2. Cut-off frequency is measured using a slotted line system at 2 GHz. $f_{co} = \frac{1}{2\pi r_s C_j}$
3. For high power applications it is essential that the heatsink end of the device is gripped by a collet or equivalent clamping system to ensure the best possible thermal conductivity. This in turn should be coupled to an adequate heatsink. Care must be taken to avoid unnecessary deformation of this diode pin, as this may cause cracking of the metal-ceramic hermetic seal. The location of the top cap should be a hold of diameter 1.8 to 2.2 mm bearing on the flange with a force not exceeding 10 N.



GALLIUM ARSENIDE PARAMETRIC AMPLIFIER VARACTOR DIODE

Gallium arsenide varactor diode with a high cut-off frequency for use in parametric amplifiers, frequency multipliers and switches. The diodes are of the diffused mesa type, are mounted in a small ceramic-metal case with a welded hermetic seal and conform to the environmental requirements of BS9300 where applicable.

QUICK REFERENCE DATA

D.C. reverse voltage	V_R	max.	6.0	V
Average forward current	$I_F(AV)$	max.	70	mA
Total power dissipation	P_{tot}	max.	50	mW
$T_{stud} \leq 107^\circ\text{C}$				
$T_{stud} > 107^\circ\text{C}$, see derating curve				
Junction operating temperature range	T_j		-196 to +150	$^\circ\text{C}$
Cut-off frequency, $V_R = 6.0\text{ V}$	f_{co}	typ.	240	GHz

This data must be read in conjunction with GENERAL SAFETY RECOMMENDATIONS – MICROWAVE SEMICONDUCTORS

MECHANICAL DATA

Dimensions in mm

Conforms to SOD-31 and BS3934 SO-86

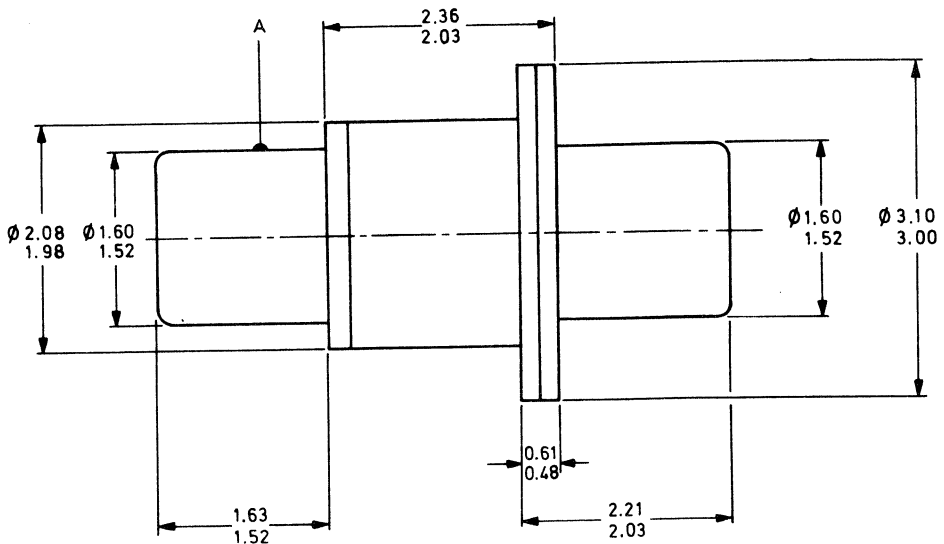

RATINGS

Limiting values in accordance with the Absolute Maximum System (IEC134)

Storage temperature range	T_{stg}		-196 to +150	°C
Junction temperature operating range	T_j		-196 to +150	°C
D.C. reverse voltage	V_R	max.	6.0	V
Average forward current	$I_F(AV)$	max.	70	mA
Total power dissipation $T_{stud} \leq 107\text{ °C}$	P_{tot}	max.	50	mW

CHARACTERISTICS ($T_{amb} = 25\text{ °C}$)

		min.	typ.	max.	
Reverse current, $V_R = 6.0\text{ V}$	I_R	—	0.1	1.0	μA
Forward voltage drop $I_F = 1.0\text{ }\mu\text{A}$ (note 3)	V_F	—	0.9	—	V
Series resonant frequency $V_R = 0$ (notes 1 and 2)	f_o	8.9	10	11.6	GHz
Cut-off frequency $V_R = 0$ (note 2)	f_{co}	125	150	—	GHz
Cut-off frequency $V_R = 6.0\text{ V}$ (note 2)	f_{co}	—	240	—	GHz
Effective diode capacitance at X-band frequency, $V_R = 0$ (notes 1 and 2)	C_{mo}	0.3	0.4	0.5	pF
Capacitance variation coefficient (note 3)	γ	0.12	0.15	—	
Stray capacitance (note 1)	C_{S1}	—	0.1	—	pF
Stray capacitance (note 1)	C_{S2}	—	0.15	—	pF
Series inductance (note 1)	L_s	—	625	—	pH

Notes

1. A suitable lumped circuit equivalent for the device may be drawn as follows:

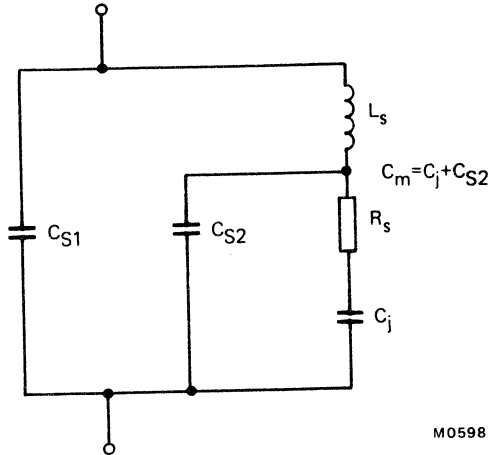

2. Measured at and about the series resonant frequency, in a suitable waveguide holder, enable the values of f_o and the diode Q factor to be determined. The effective diode capacitance and the cut-off frequency can be calculated taking L_s to be the typical value.

$$f_{co} = Q_o f_o \quad \text{where } f_o \text{ is the series resonant frequency}$$

$$Q_o \text{ is the Q factor at zero bias}$$

$$C_{mo} = \frac{1}{4\pi^2 f_o^2 L_s}$$

3. The capacitance variation coefficient γ is defined as

$$\gamma = \frac{C_m \text{ max.} - C_m \text{ min.}}{2(C_m \text{ max.} + C_m \text{ min.})}$$

where $C_m \text{ min.}$ = effective capacitance at $V_R = 1.0 \text{ V}$
 $C_m \text{ max.}$ = effective capacitance at $I_F = 1.0 \mu\text{A}$

This can be re-written in the form

$$\gamma = \frac{(1 - V)^{-1/3} - 2^{-1/3}}{2 \left[(1 - V)^{-1/3} + 2^{-1/3} \right] + \frac{4C_{S2}}{C_{jo}}}$$

where $V = V_F$ at $1.0 \mu\text{A}$
 $C_{jo} = C_{mo} - C_{S2}$

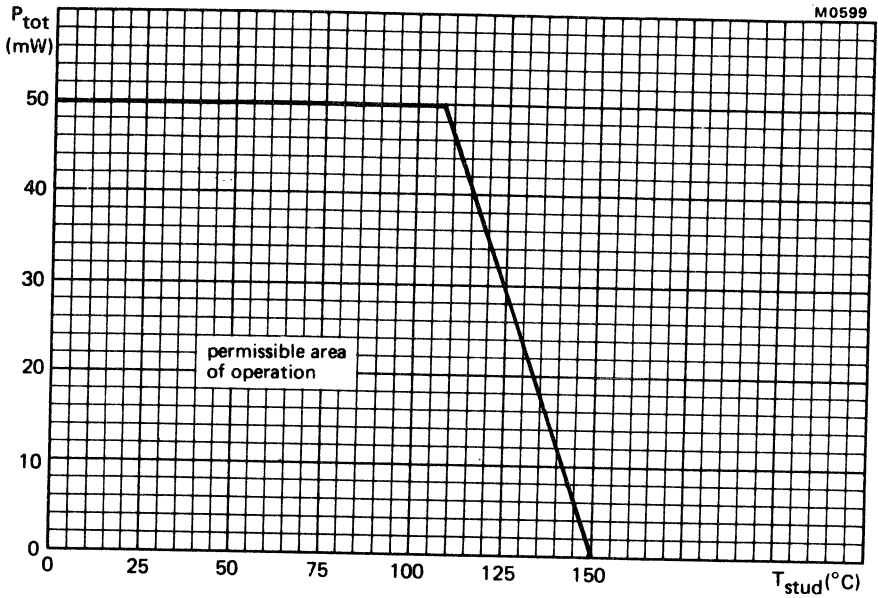

Total dissipation as a function of stud temperature

GALLIUM ARSENIDE PARAMETRIC AMPLIFIER VARACTOR DIODE

Gallium arsenide varactor diode with a high cut-off frequency suitable for use in parametric amplifiers and may be used in frequency multipliers and switches. The diodes are of the diffused mesa type, mounted in a small ceramic-metal case with a hermetic welded seal and conform to the environmental requirements of BS9300 where applicable.

QUICK REFERENCE DATA

D.C. reverse voltage	V_R	max.	6.0	V
Total power dissipation $T_{pin} \leq 25^\circ C$	P_{tot}	max.	50	mW
Typical X-band parametric amplifier performance				
Signal frequency	f		8.5	GHz
Gain			15	dB
Bandwidth (3 dB)	B		70	MHz
Noise temperature		typ.	200	°K

This data must be read in conjunction with GENERAL SAFETY RECOMMENDATIONS – MICROWAVE SEMICONDUCTORS

MECHANICAL DATA

Conforms to SOD-46

Dimensions in mm

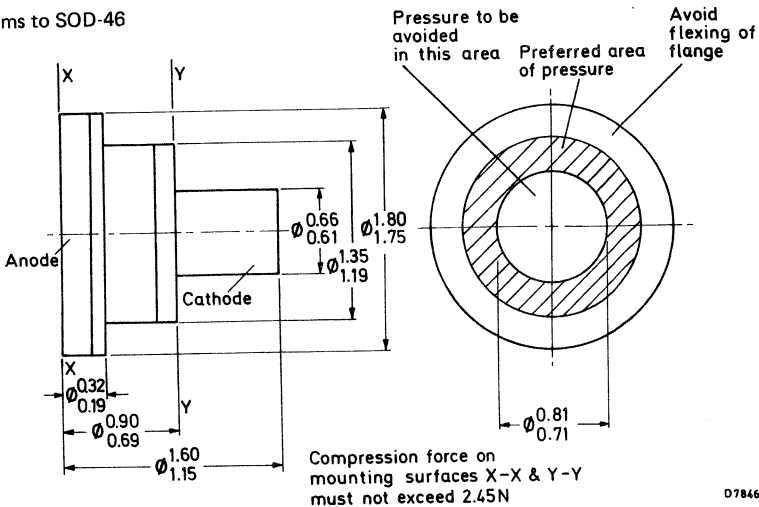

07846

Devices may be selected to suit customers' specific requirements, including alternative packages.

RATINGS

Limiting values in accordance with the Absolute Maximum System (IEC134)

Storage temperature range	T_{stg}		-196 to +175	°C
Junction temperature operating range	T_j		-196 to +135	°C
D.C. reverse voltage	V_R	max.	6.0	V
Total power dissipation $T_{pin} \leq 25$ °C	P_{tot}	max.	50	mW

THERMAL RESISTANCE

Thermal resistance from junction to pin	$R_{th\ j-pin}$	max.	0.9	°C/mW
---	-----------------	------	-----	-------

CHARACTERISTICS ($T_{amb} = 25$ °C)

		min.	typ.	max.	
Reverse current, $V_R = 6.0$ V	I_R	—	0.1	1.0	μA
Series resonant frequency $V_R = 0$ (note 1)	f_{res}	27	30	34	GHz
Cut-off frequency $V_R = 0$ (note 1)	f_{co}	200	350	—	GHz
Product of capacitance variation coefficient and cut-off frequency $V_R = 0$ (note 2)	γf_{co}	35	50	—	GHz
Microwave value of effective device series resistance (notes 1 and 4)	R_m	—	2.25	—	Ω
Microwave value of effective device capacitance $V_R = 0$ (notes 3 and 4)	C_m	—	0.2	—	pF
Stray capacitance (L.F. measurement)	C_s	—	0.3	—	pF
Microwave value of effective device series inductance (note 3)	L_s	—	140	—	pH

Notes

1. Measured in a reduced height waveguide holder at Q-band.
2. γf_{co} is guaranteed by a functional X-band paramp test at room temperature. The capacitance variation coefficient, γ , is defined as follows:

$$\gamma = \frac{C_m \text{ max.} - C_m \text{ min.}}{2(C_m \text{ max.} + C_m \text{ min.})}$$

where $C_m \text{ min.}$ = effective capacitance at $V_R = 1.0$ V
 $C_m \text{ max.}$ = effective capacitance at $I_F = 1.0$ μA

3. C_m is calculated using the frequency cut-off and the series resistance:

$$C_m = \frac{1}{2\pi R_m f_{co}}$$

L_s is also calculated using f_{res} and C_m :

$$L_s = \frac{1}{4\pi^2 f_{res}^2 C_m}$$

Notes (continued)

4. (a) Diode circuit model.
- (b) Equivalent circuit in measuring holder.

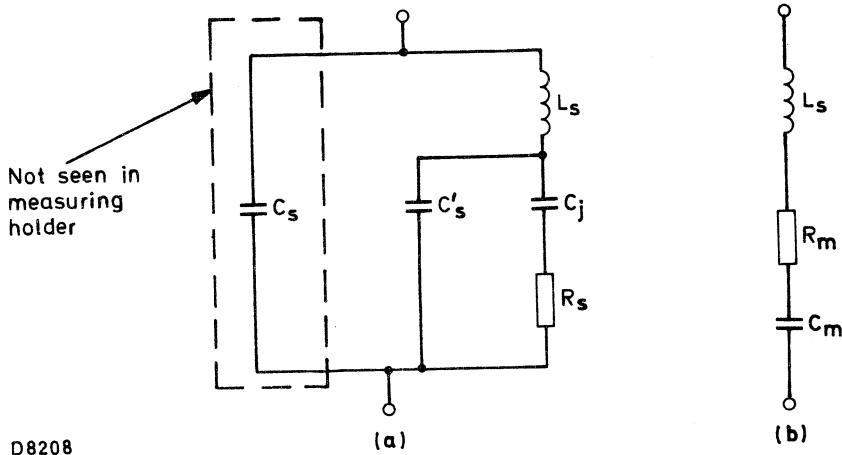

Operating note

The CXY10 varactor diode will give good noise performance in a parametric amplifier of suitable design.

For example:

The effective input noise temperature of the amplifier, less the contribution due to the circulator, would be typically 200 °K and a maximum of 250 °K, with the amplifier at room temperature under the following conditions:

gain	15 dB
bandwidth	50 MHz (3 dB)
signal frequency	in X-band
overcoupled ratio	4 to 5 dB
pump frequency	in Q-band

In cooled parametric amplifiers, the device would give appropriately lower effective input noise temperatures due to its low temperature working capability.

GALLIUM ARSENIDE MULTIPLIER VARACTOR DIODE

Gallium arsenide varactor diode suitable for use in frequency multiplier circuits up to Q-band output frequency. The diodes are of the diffused mesa type, are mounted in a small ceramic-metal case with hermetic welded seal and conform to the environmental requirements of BS9300 where applicable.

QUICK REFERENCE DATA

Operation as a frequency quadrupler 9.0 to 36 GHz in a typical circuit.

Input r.f. power	P_{in}	max.	500	mW
Output r.f. power	P_{out}	min.	50	mW
Resistive cut-off frequency, $V_R = 6.0$ V	f_{co}	typ.	500	GHz
Junction temperature	T_j	max.	175	°C

This data must be read in conjunction with GENERAL SAFETY RECOMMENDATIONS — MICROWAVE SEMICONDUCTORS

Dimensions in mm

MECHANICAL DATA

Conforms to SOD-46

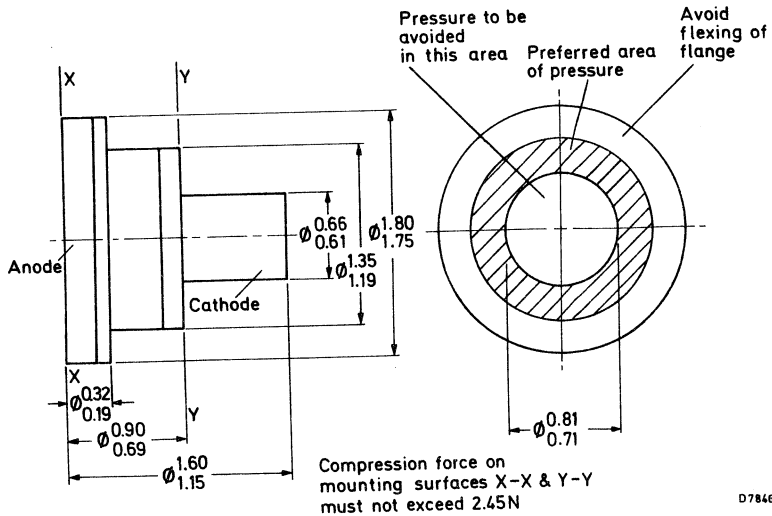

D7846

Devices may be selected to suit customers' specific requirements, including alternative packages.

RATINGS

Limiting values in accordance with the Absolute Maximum System (IEC134)

Storage temperature range	T_{stg}	-55 to +175	°C
Junction temperature	T_j	max. 175	°C
D.C. reverse voltage	V_R	max. 10	V
Total power dissipation $T_{pin} = 25\text{ °C}$ (note 1)	P_{tot}	max. 300	mW
Input power R.F.	P_{in}	max. 500	mW

THERMAL RESISTANCE

Thermal resistance from junction to pin	$R_{th\ j-pin}$	max. 0.5	°C/mW
---	-----------------	----------	-------

CHARACTERISTICS ($T_{amb} = 25\text{ °C}$)

		min.	typ.	max.	
Reverse breakdown voltage $I_R = 100\ \mu A$	$V_{(BR)R}$	10	15	—	V
Reverse current, $V_R = 6.0\text{ V}$	I_R	—	0.001	1.0	μA
Series resonance frequency $V_R = 6.0\text{ V}$ (note 2)	f_{res}	27	29	35	GHz
Cut-off frequency $V_R = 6.0\text{ V}$ (note 2)	f_{co}	300	500	—	GHz
Microwave value of effective device capacitance $V_R = 6.0\text{ V}$ (note 3)	C_m	—	0.25	—	pF
Microwave value of effective device series resistance $V_R = 6.0\text{ V}$ (notes 2 and 4)	R_m	—	1.3	—	Ω
Stray case capacitance (L.F. measurement)	C_s	—	0.3	—	pF
Microwave value of effective device series inductance (note 3)	L_s	—	120	—	pH

Notes

1. The maximum value of P_{tot} is based on a d.c. dissipation life test. The R.F. power may well exceed this figure in a practical circuit.

2. Measurements on semiconductor devices at microwave frequencies are very much dependent upon the kind of holder used. The dynamic parameters are quoted using a holder which takes the form of a double four section Q-band (Ka-band) 26 to 40 GHz waveguide wide band low v.s.w.r. transformer to a reduced height of 0.25 mm. The transformer is step down followed by step up in order to use standard Q-band components on either side. A d.c. isolated coaxial choke system allows the diode to be inserted across the 0.25 mm reduced height section and to be biased. Using a swept frequency transmission loss measurement system, the series resonant frequency and the Q of the diode holder system can be measured. Hence, the resistive cut-off frequency which is defined as $Q \times f_{res}$.

Separately, by measuring the transmission loss past the diode at resonance, the effective diode series resistance can be found.

3. C_m is calculated using the frequency cut-off and the series resistance:

$$C_m = \frac{1}{2\pi R_m f_{co}}$$

L_s is also calculated using f_{res} and C_m :

$$L_s = \frac{1}{4\pi^2 f_{res}^2 C_m}$$

4. (a) Diode circuit model.

(b) Equivalent circuit in measuring holder.

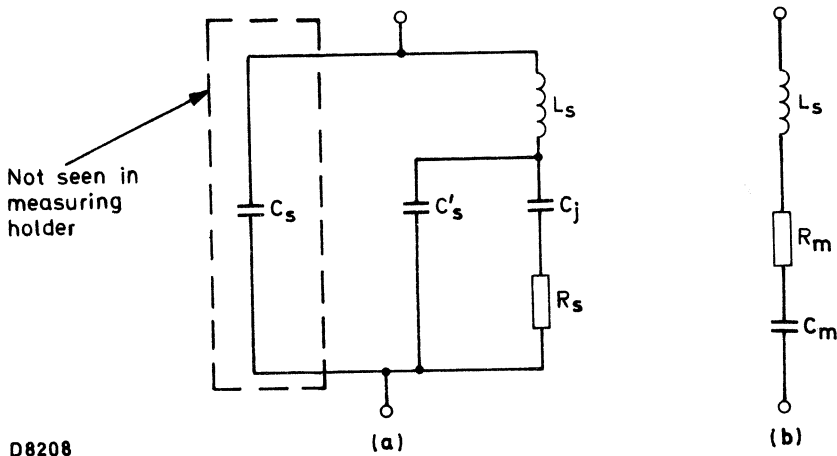

Application note

In a suitable frequency quadrupler, this device is capable of producing 50 mW at 36 GHz for an input of 400 mW at 9.0 GHz.

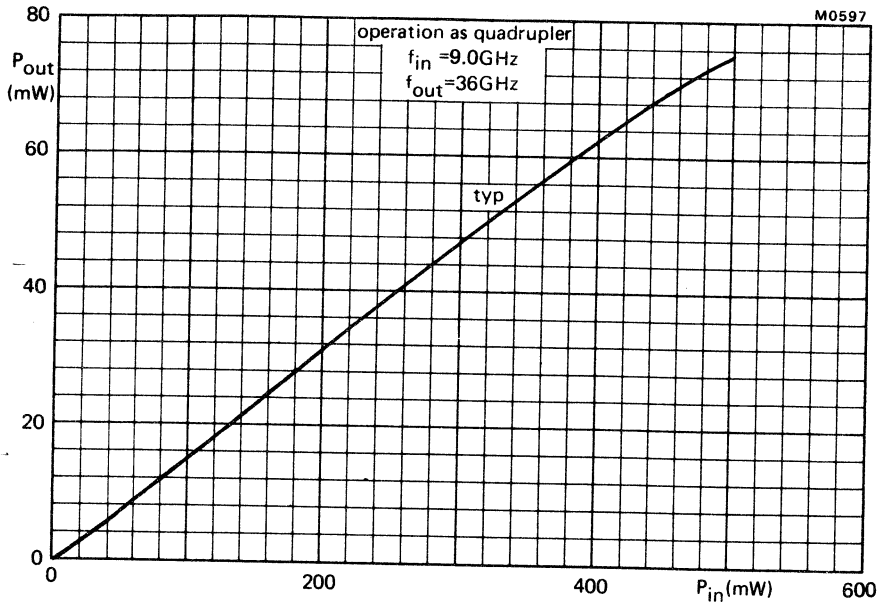

Output power as a function of input power
Quadrupler operation

STEP RECOVERY DIODES

Silicon planar epitaxial varactor diodes exhibiting step recovery characteristics, especially suitable for use in frequency multiplier circuits up to S-band output frequency. They conform to the environmental requirements of BS9300 where applicable.

QUICK REFERENCE DATA

Operation as a frequency doubler 1 to 2 GHz in a typical circuit.

Input r.f. power	P_{in}	12	W
Output r.f. power	P_{out}	6.0	W
Resistive cut-off frequency $V_R = 6.0$ V	f_{co}	typ. 100	GHz
Total capacitance, $V_R = 6.0$ V	C_T	typ. 6.0	pF

Unless otherwise stated, data is applicable to both types.

This data must be read in conjunction with GENERAL SAFETY RECOMMENDATIONS – MICROWAVE SEMICONDUCTORS

MECHANICAL DATA

Dimensions in mm

Outline drawing of 1N5152
Conforms to SOD-31

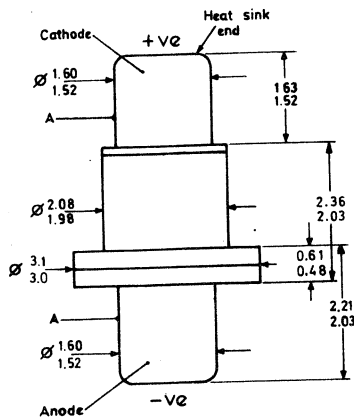

A = concentricity tolerance = ± 0.13

Outline drawing of 1N5153
Conforms to SOD-43

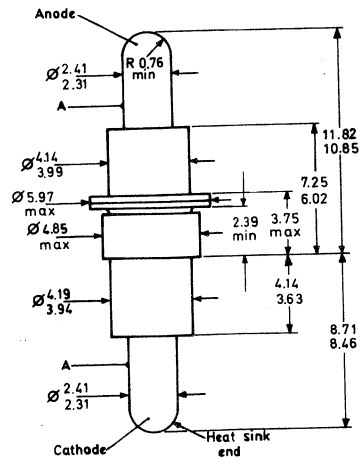

D7840

Devices may be selected to suit customers' specific requirements, including alternative packages.

RATINGS

Limiting values in accordance with the Absolute Maximum System (IEC134)

Storage temperature range	T_{stg}	-55 to +175	°C
Junction temperature	T_j	max. 175	°C
D.C. reverse voltage	V_R	max. 75	V
Total power dissipation R.F. $T_{pin} \leq 70$ °C	P_{tot}	max. 5.0	W

THERMAL RESISTANCE

Thermal resistance from junction to pin	$R_{th\ j-pin}$	max. 20	°C/W
---	-----------------	---------	------

CHARACTERISTICS ($T_{amb} = 25$ °C)

		min.	typ.	max.	
Reverse breakdown voltage, $I_R = 10$ μ A	$V_{(BR)R}$	75	-	-	V
Reverse current, $V_R = 60$ V	I_R	-	0.001	1.0	μ A
Forward voltage, $I_F = 10$ mA	V_F	-	-	1.0	V
Cut-off frequency, $V_R = 6.0$ V, $f_{measured} = 2.0$ GHz	f_{co}	55	100	-	GHz
Total capacitance $V_R = 6.0$ V, $f = 1.0$ MHz	C_T	5.0	-	7.5	pF
Overall efficiency $P_{in} = 12$ W, $f_{in} = 1.0$ GHz frequency doubler	η	50	60	-	%



STEP RECOVERY DIODE

Silicon planar epitaxial varactor diode exhibiting step recovery characteristics, especially suitable for use in frequency multiplier circuits up to C-band output frequency. It conforms to the environmental requirements of BS9300 where applicable.

QUICK REFERENCE DATA

Operating as a frequency tripler 2 to 6 GHz in a typical circuit.

Input r.f. power	P_{in}	5.0	W
Output r.f. power	P_{out}	2.0	W
Resistive cut-off frequency, $V_R = 6.0$ V	f_{co}	typ. 120	GHz
Total capacitance, $V_R = 6.0$ V	C_T	typ. 2.0	pF

This data must be read in conjunction with GENERAL SAFETY RECOMMENDATIONS – MICROWAVE SEMICONDUCTORS

MECHANICAL DATA

Dimensions in mm

Conforms to SOD-31

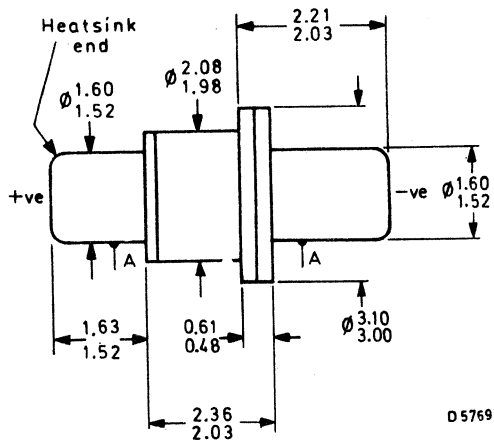

A = concentricity tolerance = ± 0.13

Devices may be selected to suit customers' specific requirements, including alternative packages.

RATINGS

Limiting values in accordance with the Absolute Maximum System (IEC134)

Storage temperature range	T_{stg}	-55 to +175	$^{\circ}\text{C}$
Junction temperature	T_j	max. 175	$^{\circ}\text{C}$
D.C. reverse voltage	V_R	max. 35	V
Total power dissipation R.F. $T_{pin} \leq 70^{\circ}\text{C}$	P_{tot}	max. 3.0	W

THERMAL RESISTANCE

Thermal resistance from junction to pin	$R_{th\ j-pin}$	max. 35	$^{\circ}\text{C/W}$
---	-----------------	---------	----------------------

CHARACTERISTICS ($T_{amb} = 25^{\circ}\text{C}$)

		min.	typ.	max.	
Reverse breakdown voltage, $I_R = 10\ \mu\text{A}$	$V_{(BR)R}$	35	—	—	V
Reverse current, $V_R = 26\ \text{V}$	I_R	—	0.001	1.0	μA
Forward voltage, $I_F = 10\ \text{mA}$	V_F	—	—	1.0	V
Cut-off frequency, $V_R = 6.0\ \text{V}$, $f_{measured} = 2.0\ \text{GHz}$	f_{co}	100	120	—	GHz
Total capacitance $V_R = 6.0\ \text{V}$, $f = 1.0\ \text{MHz}$	C_T	1.0	—	3.0	pF
Overall efficiency $P_{in} = 5.0\ \text{W}$, $f_{in} = 2.0\ \text{GHz}$, frequency tripler	η	40	—	—	%

STEP RECOVERY DIODE

Silicon planar epitaxial varactor diode exhibiting step recovery characteristics, especially suitable for use in frequency multiplier circuits up to X-band output frequency. It conforms to the environmental requirements of BS9300 where applicable.

QUICK REFERENCE DATA

Operating as a frequency doubler 5 to 10 GHz in a typical circuit.

Input r.f. power	P_{in}	2.6	W
Output r.f. power	P_{out}	1.0	W
Resistive cut-off frequency, $V_R = 6.0$ V	f_{co}	typ. 200	GHz
Total capacitance, $V_R = 6.0$ V	C_T	typ. 0.8	pF

This data must be read in conjunction with GENERAL SAFETY RECOMMENDATIONS – MICROWAVE SEMICONDUCTORS

MECHANICAL DATA

Dimensions in mm

Conforms to SOD-31

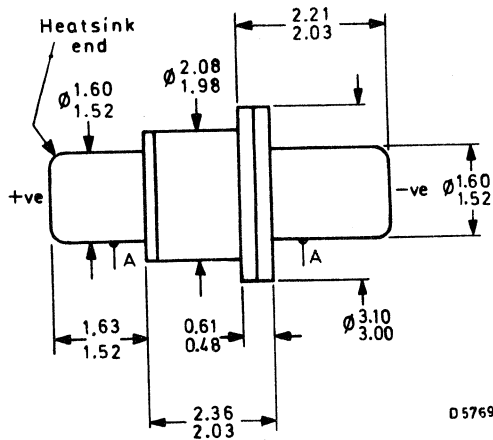

A = concentricity tolerance = ± 0.13

Devices may be selected to suit customers' specific requirements, including alternative packages.

RATINGS

Limiting values in accordance with the Absolute Maximum System (IEC134)

Storage temperature range	T_{stg}	-55 to +175	°C
Junction temperature	T_j	max. 175	°C
D.C. reverse voltage	V_R	max. 20	V
Total power dissipation R.F. $T_{pin} \leq 70$ °C	P_{tot}	max. 2.5	W

THERMAL RESISTANCE

Thermal resistance from junction to pin	$R_{th\ j-pin}$	max. 38.5	°C/W
---	-----------------	-----------	------

CHARACTERISTICS ($T_{amb} = 25$ °C)

		min.	typ.	max.	
Reverse breakdown voltage, $I_R = 10$ μ A	$V_{(BR)R}$	20	—	—	V
Reverse current, $V_R = 16$ V	I_R	—	—	0.1	μ A
Forward voltage, $I_F = 10$ mA	V_F	—	—	1.0	V
Cut-off frequency, $V_R = 6.0$ V $f_{measured} = 8.0$ GHz	f_{co}	180	200	—	GHz
Total capacitance $V_R = 6.0$ V, $f = 1.0$ MHz	C_T	0.6	—	1.0	pF
Overall efficiency $P_{in} = 2.6$ W, $f_{in} = 5.0$ GHz frequency doubler	η	38	—	—	%

TUNING VARACTOR DIODES

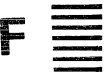

≡ F

SILICON PLANAR VARACTOR TUNING DIODES

This is a range of planar epitaxial varactor tuning diodes with highly reproducible abrupt junction performance. The devices are specifically designed for frequency tuning in military and professional applications where high stability is essential.

A $\pm 10\%$ capacitance tolerance is supplied as standard; closer tolerances are available on request. This series of diodes is available in a wide range of ceramic packages, including those shown here. They conform to the environmental requirements of BS CECC 50.006-010 where applicable.

This data must be read in conjunction with GENERAL SAFETY RECOMMENDATIONS - MICROWAVE SEMICONDUCTORS

RATINGS

Limiting values in accordance with the Absolute Maximum System (IEC 134)

Storage temperature range		T_{stg}	-65 to +150	°C
Ambient temperature range for operation		T_{amb}	-65 to +150	°C
Reverse voltage	BXY48-20	V_R	max.	20 V
	BXY48-30	V_R	max.	30 V
	BXY48-40	V_R	max.	40 V

CHARACTERISTICS ($T_{amb} = 25^\circ\text{C}$)

20 volt series, BXY48-20

		min.	typ.	max.	
Reverse breakdown voltage, $I_R = 10 \mu\text{A}$	$V_{(BR)R}$	22	25	-	V
Reverse leakage current, $V_R = 20 \text{ V}$	I_R	-	-	0.1	μA
Junction capacitance, -4 V (note 1)	C_j	0.3	-	1.6	pF
Capacitance law (note 2)					
Q at -4 V (note 3)		-	2500	-	

30 volt series, BXY48-30

Reverse breakdown voltage, $I_R = 10 \mu\text{A}$	$V_{(BR)R}$	33	36	-	V
Reverse leakage current, $V_R = 30 \text{ V}$	I_R	-	-	0.1	μA
Junction capacitance, -4 V (note 1)	C_j	0.4	-	1.8	pF
Capacitance law (note 2)					
Q at -4 V (note 3)		-	1500	-	

40 volt series, BXY48-40

Reverse breakdown voltage, $I_R = 10 \mu\text{A}$	$V_{(BR)R}$	45	48	-	V
Reverse leakage current, $V_R = 40 \text{ V}$	I_R	-	-	0.1	μA
Junction capacitance, -4 V (note 1)	C_j	0.6	-	4.5	pF
Capacitance law (note 2)					
Q at -4 V (note 3)		-	1000	-	

Notes

1. The customer should specify the required total capacitance value and measurement voltage (0 or -4 V). A $\pm 10\%$ capacitance tolerance is supplied as standard; closer tolerances are available on request.
Capacitance is measured at 1 MHz.
2. All junctions are abrupt and obey the following law:

$$C_T = C_{j0} \left(1 + \frac{V_R}{\phi}\right)^{-n} + C_S$$

where C_T is total capacitance
 C_{j0} is zero bias junction capacitance
 V_R is reverse voltage
 ϕ is 0.65 V, typically
 n is 0.46, typically
 C_S is package capacitance

3. Measurements at microwave frequencies are converted to Q at 50 MHz.
4. Case parasitics C_S and L_S are shown on the outline drawings.

Ordering information

When ordering, please specify:

1. Reverse breakdown voltage.
2. Total capacitance and measurement voltage.
3. Capacitance tolerance.
4. Case style.

MECHANICAL DATA

Dimensions in mm

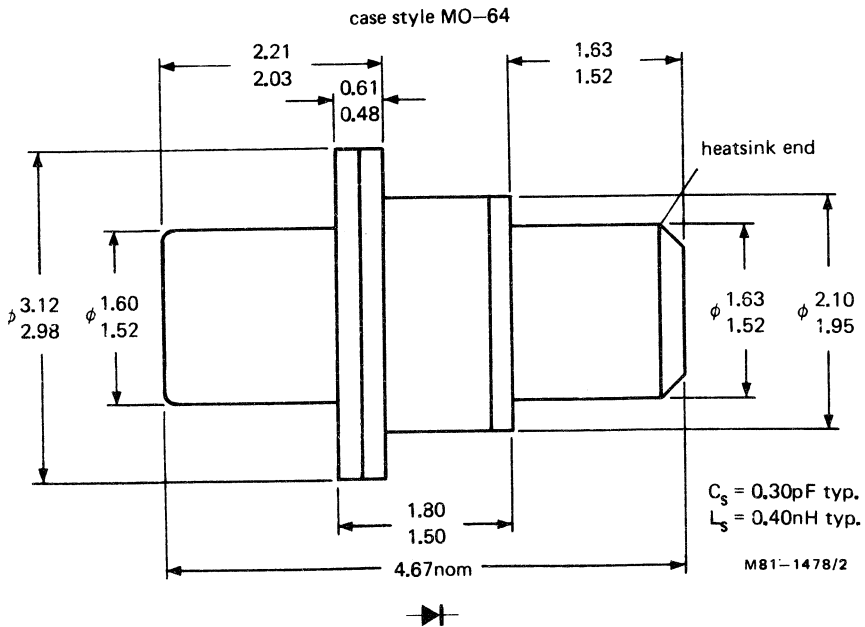
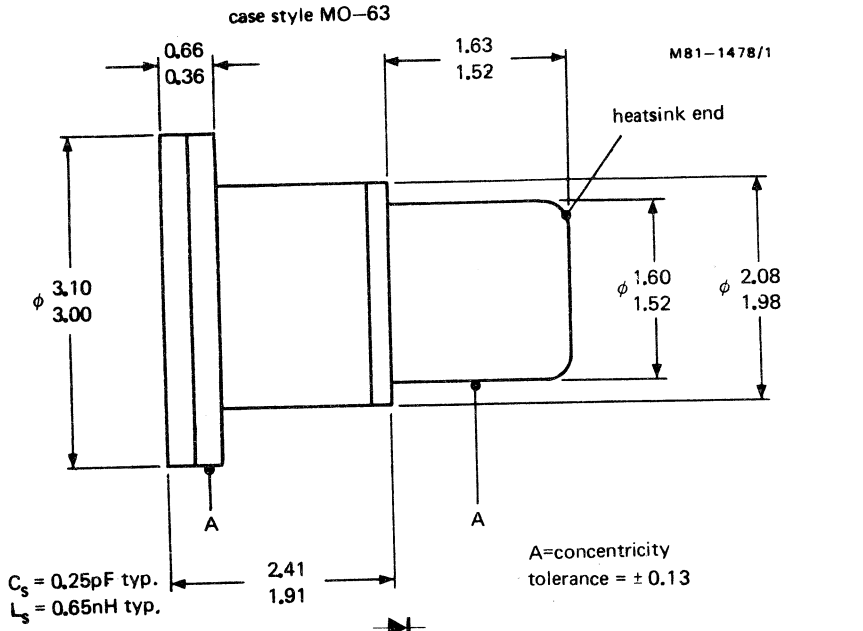

BXY48 SERIES

case style MO-65

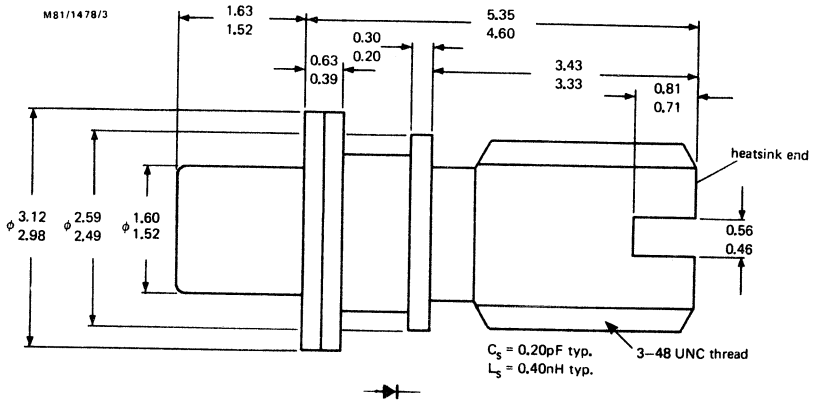

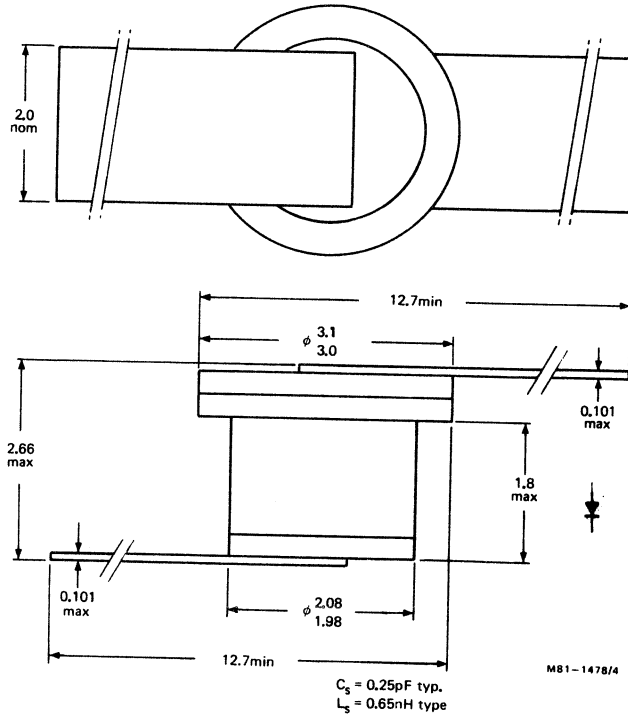

case style MO-66

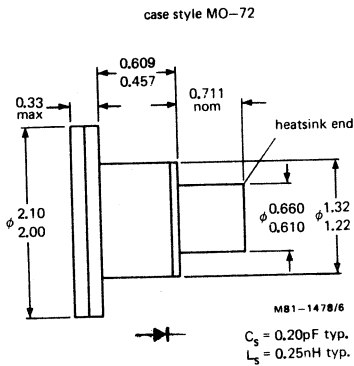
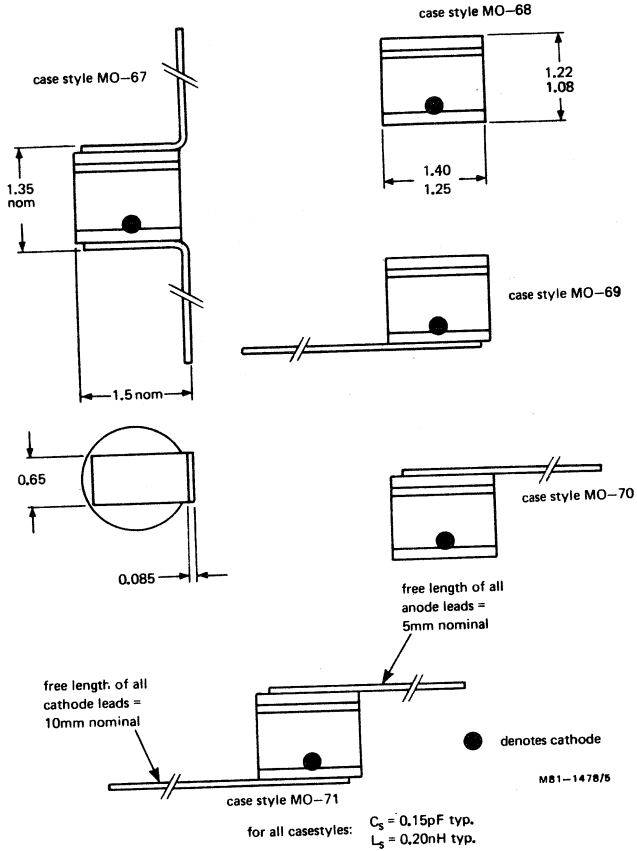

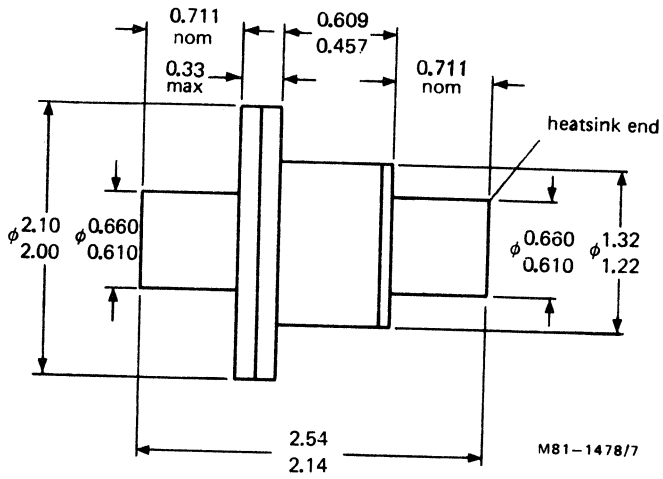

case style MO-73



 $C_s = 0.20\text{pF typ.}$
 $L_s = 0.25\text{nH typ.}$

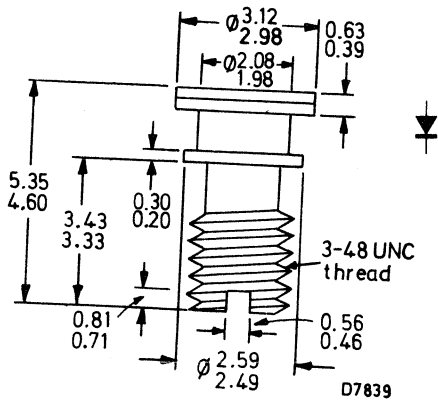

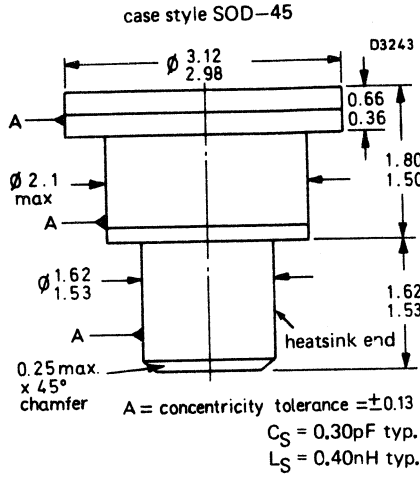

case style SOD-31
 conforms to BS3934 SO-86

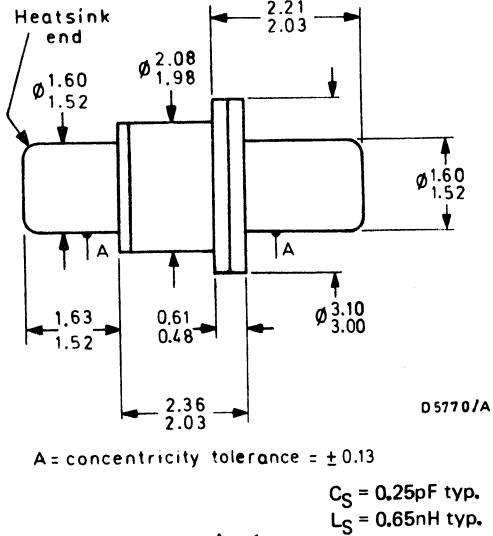

SILICON VARACTOR TUNING DIODES

This is a range of epitaxial silicon tuning varactor diodes of the mesa type. The device structure is optimized for abrupt junction performance and highest Q. They are useful in a large number of microwave tuning applications and are available in a wide range of ceramic packages. A $\pm 10\%$ capacitance tolerance is supplied as standard; closer tolerances are available on request.

This data must be read in conjunction with GENERAL SAFETY RECOMMENDATIONS – MICROWAVE SEMICONDUCTORS

RATINGS

Limiting values in accordance with the Absolute Maximum System (IEC 134)

Storage temperature range	T_{stg}	-55 to +150	$^{\circ}\text{C}$
Ambient temperature range for operation	T_{amb}	-55 to +150	$^{\circ}\text{C}$
Reverse voltage (note 1)	V_R	max. 60	V

CHARACTERISTICS ($T_{amb} = 25^{\circ}\text{C}$)

		min.	typ.	max.	
Reverse breakdown voltage, $I_R = 10 \mu\text{A}$	$V_{(BR)R}$	60	65	—	V
Reverse leakage current, $V_R = 55 \text{ V}$	I_R	—	—	1.0	μA
Junction capacitance, -4 V (note 2)	C_j	0.6	—	4.5	pF
Capacitance law (note 3)					
Q at -4 V (note 4)		typ.	2000 for 0.8 pF devices		
		typ.	1500 for 4.7 pF devices		

Notes

- Below 25°C V_R max. must be derated at $7 \times 10^{-2} \text{ V}/^{\circ}\text{C}$.
- The customer should specify the required total capacitance value and measurement voltage (0 or -4 V). A $\pm 10\%$ capacitance tolerance is supplied as standard; closer tolerances are available on request.
Capacitance is measured at 1 MHz.
- All junctions are abrupt and obey the following law:

$$C_T = C_{j0} \left(1 + \frac{V_R}{\phi} \right)^{-n} + C_s$$

where C_T is total capacitance
 C_{j0} is zero bias junction capacitance
 V_R is reverse voltage
 ϕ is 0.65 V, typically
 n is 0.46, typically
 C_s is package capacitance

- Measurements at microwave frequencies are converted to Q at 50 MHz.
- Case parasitics C_s and L_s are shown on the outline drawings.

Ordering information

When ordering, please specify:

1. Total capacitance and measurement voltage.
2. Capacitance tolerance.
3. Case style.

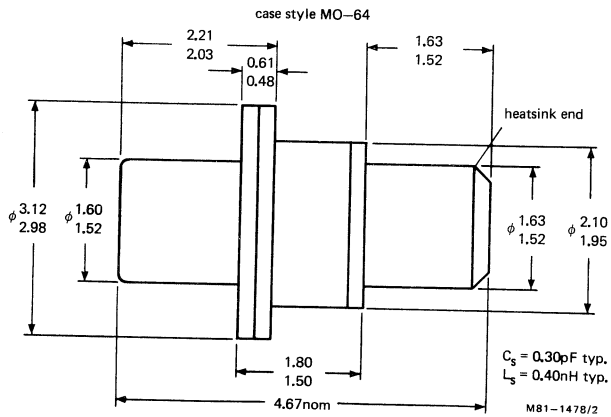
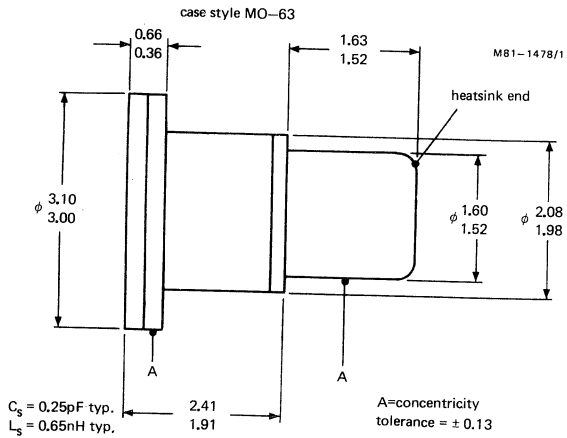

case style MO-65

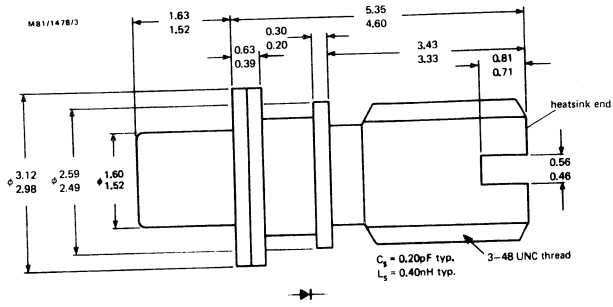

case style MO-66

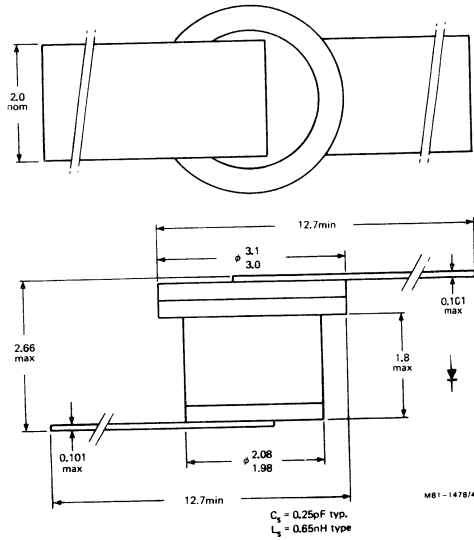

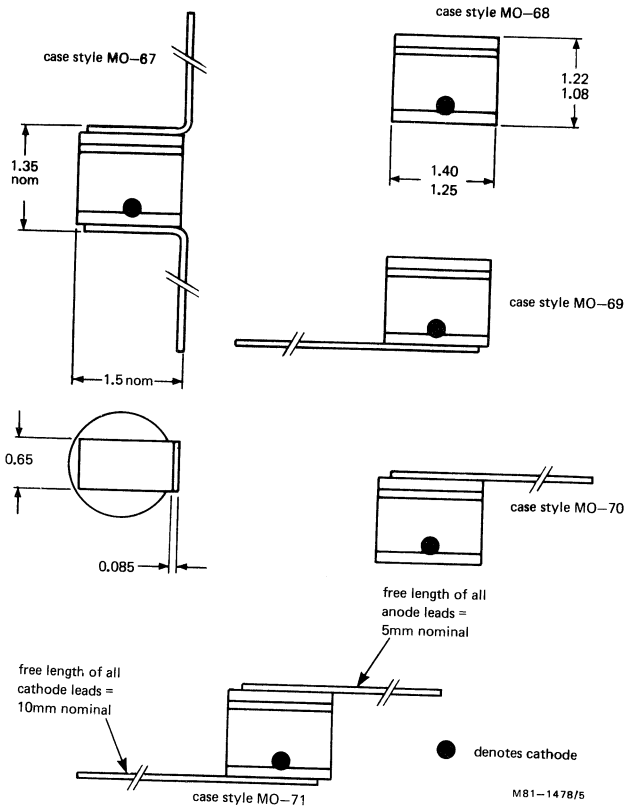

for all casestyles: $C_s = 0.15\text{pF typ.}$
 $L_s = 0.20\text{nH typ.}$

case style MO-72

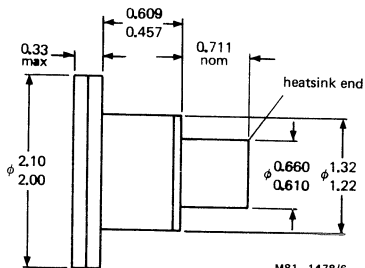

$C_s = 0.20\text{pF typ.}$
 $L_s = 0.25\text{nH typ.}$

case style MO-73

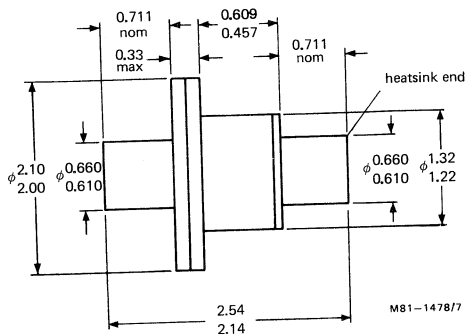

$C_S = 0.20\text{pF typ.}$
 $L_S = 0.25\text{nH typ.}$

case style SOD-44

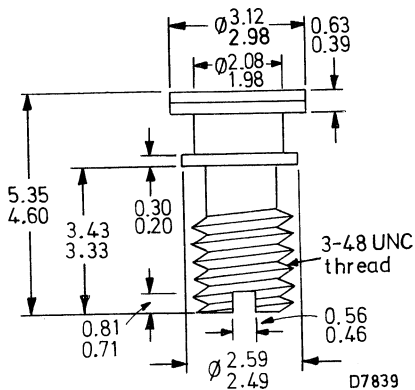

heatsink end

$C_S = 0.25\text{pF typ.}$
 $L_S = 0.65\text{nH typ.}$

case style SOD-45

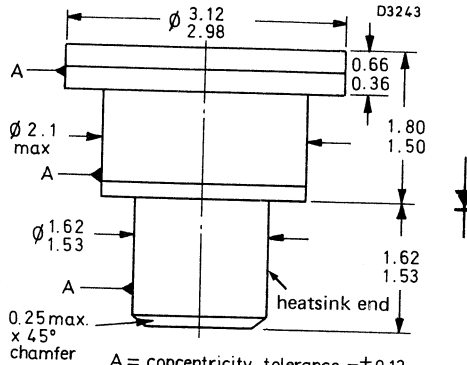

A = concentricity tolerance = ± 0.13
 $C_S = 0.30\text{pF typ.}$
 $L_S = 0.40\text{nH typ.}$

case style SOD-31
 conforms to BS3934 SO-86

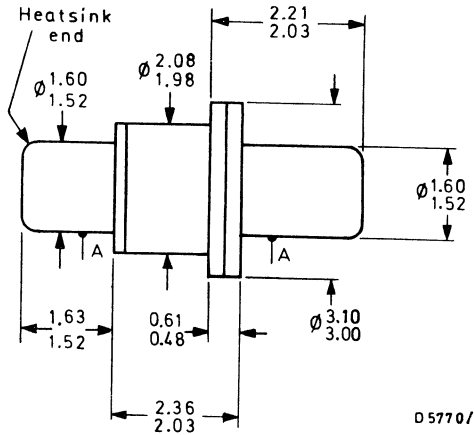

A = concentricity tolerance = ± 0.13
 $C_S = 0.25\text{pF typ.}$
 $L_S = 0.65\text{nH typ.}$



GALLIUM ARSENIDE TUNING DIODES

This is a range of high Q gallium arsenide varactor tuning diodes with highly reproducible abrupt junction performance. The devices are specifically designed for broadband tuning applications up to Q-band (Ka-band). A $\pm 10\%$ capacitance tolerance is supplied as standard; closer tolerances are available on request.
This series of diodes is available in a wide range of ceramic packages.

This data must be read in conjunction with GENERAL SAFETY RECOMMENDATIONS – MICROWAVE SEMICONDUCTORS

RATINGS

Limiting values in accordance with the Absolute Maximum System (IEC 134)

Storage temperature range	T_{stg}	-55 to +150	°C
Ambient temperature range for operation	T_{amb}	-55 to +150	°C
Reverse voltage	V_R	max. 30	V

CHARACTERISTICS ($T_{amb} = 25\text{ }^\circ\text{C}$)

		min.	typ.	max.	
Reverse breakdown voltage, $I_R = 10\ \mu\text{A}$	$V_{(BR)R}$	35	—	—	V
Junction capacitance, 0 V (note 1)	C_j	0.6	—	4.8	
Junction capacitance, -4 V (note 1)	C_j	0.3	—	2.0	pF
Capacitance law (note 2)					
Q at -4 V (note 3)		—	6000	—	

Notes

- The customer should specify the required total capacitance value and measurement voltage (0 or -4 V). A $\pm 10\%$ capacitance tolerance is supplied as standard; closer tolerances are available on request.
Capacitance is measured at 1 MHz.
- All junctions are abrupt and obey the following law:

$$C_T = C_{j0} \left(1 + \frac{V_R}{\phi} \right)^{-n} + C_s$$

where C_T is total capacitance

C_{j0} is zero bias junction capacitance

V_R is reverse voltage

ϕ is 0.65 V typically

n is 0.46, typically

C_s is package capacitance

- Measurements at microwave frequencies are converted to Q at 50 MHz.
- Case parasitics C_s and L_s are shown on the outline drawings.

Ordering information

When ordering, please specify:

1. Total capacitance and measurement voltage.
2. Capacitance tolerance.
3. Case style.

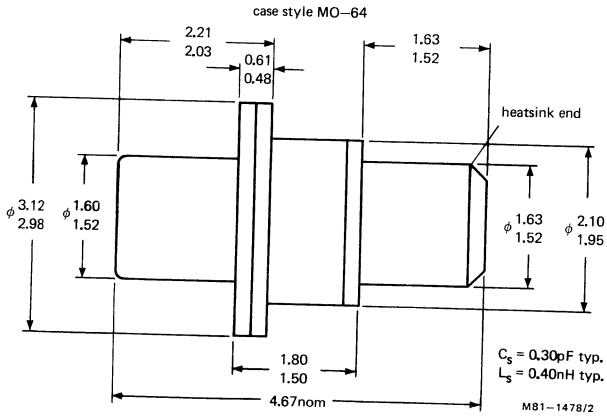
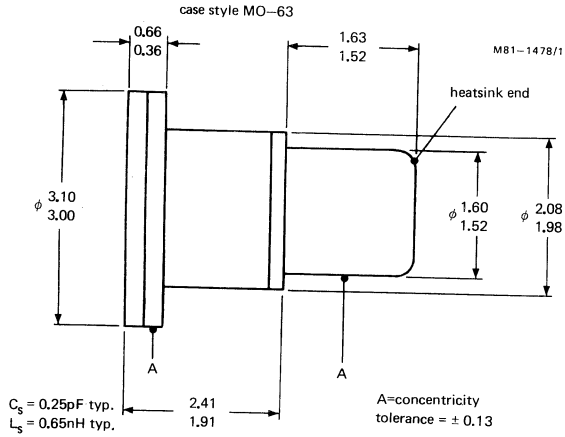

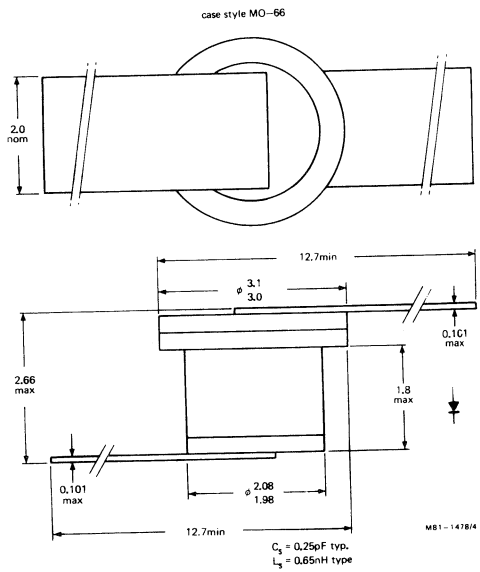
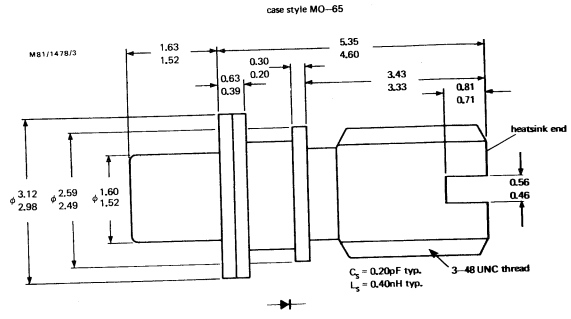

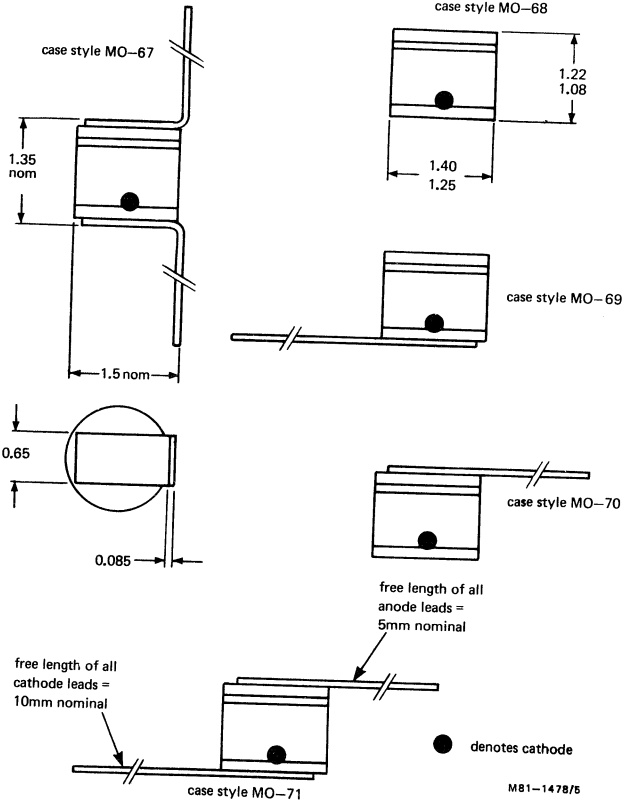

for all casestyles: $C_s = 0.15\text{pF typ.}$
 $L_s = 0.20\text{nH typ.}$

case style MO-72

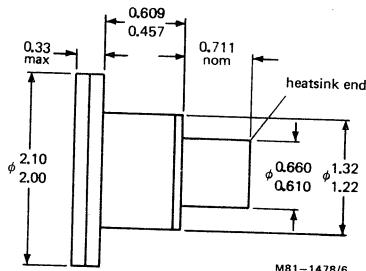

$C_s = 0.20\text{pF typ.}$
 $L_s = 0.25\text{nH typ.}$

case style MO-73

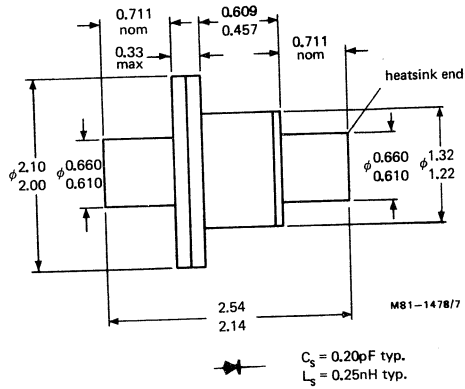

case style SOD-44

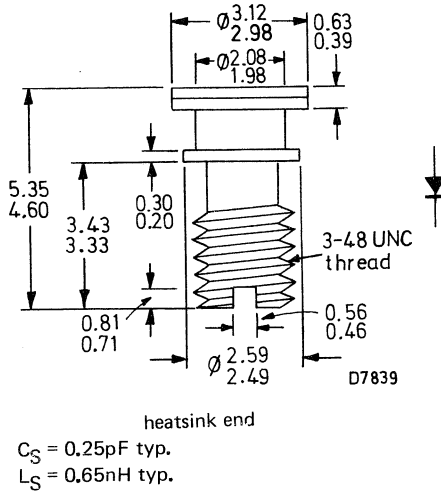

case style SOD-45

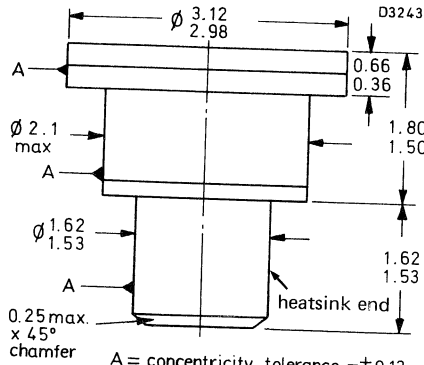

A = concentricity tolerance = ± 0.13

$C_S = 0.30\text{pF typ.}$

$L_S = 0.40\text{nH typ.}$

case style SOD-31

conforms to BS3934 SO-86

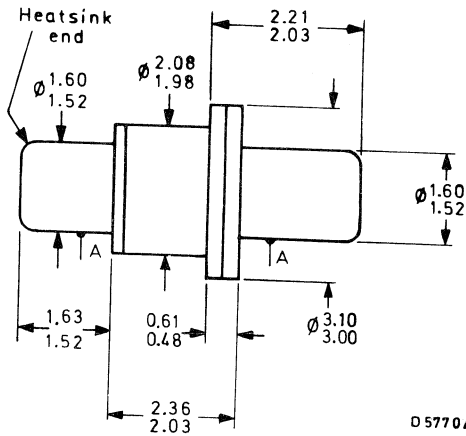

A = concentricity tolerance = ± 0.13

$C_S = 0.25\text{pF typ.}$

$L_S = 0.65\text{nH typ.}$



LIMITER VARACTOR DIODES





GALLIUM ARSENIDE LIMITER DIODES

Gallium arsenide varactor diodes for limiter applications from C to X-band. Very low insertion loss and high isolation characteristics may be obtained. The diodes are of the diffused mesa type and are mounted in standard microwave packages. They conform to the environmental requirements of BS9300 where applicable.

QUICK REFERENCE DATA

		CXY22A	CXY22B	
Operating frequency range	f	2.0 to 7.0	7.0 to 12	Ghz
Total capacitance at 0 V	C _T	0.85	0.55	pF
Insertion loss*	typ.	0.2	0.3	dB
High power attenuation*	typ.	20	16	dB

*Depends on circuit configuration, see page 2

Unless otherwise shown, data is applicable to both types.

This data must be read in conjunction with GENERAL SAFETY RECOMMENDATIONS — MICROWAVE SEMICONDUCTORS

MECHANICAL DATA

Dimensions in mm

Conforms to SOD-31 and BS3934 SO-86

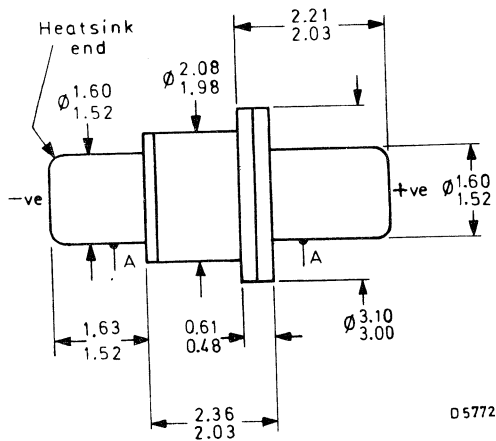

A = concentricity tolerance = ± 0.13

Devices may be selected to suit customers' specific requirements, including alternative packages. It is recommended that the device is functionally tested, by the supplier, in the customer's circuit.

RATINGS

Limiting values in accordance with the Absolute Maximum System (IEC134)

Storage temperature range	T_{stg}	-55 to +150	°C
Ambient temperature range	T_{amb}	-55 to +100	°C
D.C. reverse voltage	V_R max.	6.0	V

CHARACTERISTICS

		CXY22A	CXY22B	
Reverse current, $V_R = 6.0$ V	I_R max.	1.0	1.0	μA
D.C. forward voltage, $I_F = 50$ mA	V_F max.	1.45	1.45	V
Total capacitance, $V_R = 0$, $f = 1$ MHz	C_T typ.	0.85	0.55	pF
Series resistance, $V_R = 0$	r_s typ.	1.0	1.2	Ω

TYPICAL X-BAND LIMITER USING CXY22B

This is a resonant circuit in rectangular waveguide, operating by reflection of a high input power:

Centre frequency	f_o	9.4	GHz
Bandwidth at 1 mW max., v.s.w.r. = 1.2:1	Δf_o	300	MHz
Insertion loss at 1 mW max.		0.3	dB
Insertion loss at 100 mW, c.w.		6.0	dB
Insertion loss at 5 W peak, p.r.f. 1 kHz, 1 μs		16	dB
Safe peak power handling*, p.r.f. 1 kHz, 1 μs		50	W

*Peak power handling depends on pulse length and duty cycle, as well as circuit design.

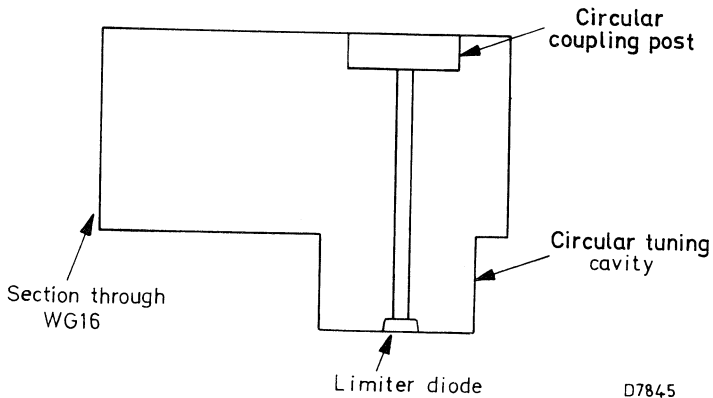

D7845

SILICON BIPOLAR TRANSISTORS





SILICON BIPOLAR TRANSISTORS GENERAL OPERATIONAL RECOMMENDATIONS

INTRODUCTION

These devices operate at high frequencies and high powers. To avoid damage or destruction, it is advisable to follow the advice given below during testing, setting-up procedures and final operation.

MECHANICAL

1. Good thermal and electrical conductivity is essential for efficient operation. Any metallic interface may introduce local overheating and an increase in contact resistance. It is therefore essential to use an adequate heatsink and heatsink compound between the rear face of the transistor or its flange and the heatsink.
2. Connections between the test jig or amplifier circuitry must be as short as possible, in any case not more than 100 μm . Special care must be taken to use the shortest possible high frequency earth (ground) connection.
3. When mounting the transistor on its heatsink, the recommended torque must not be exceeded.

POLARIZATION

1. When testing transistors in a new circuit, it is recommended that the supply voltage is reduced to approximately 70% of its nominal value and that series emitter or collector resistors are used (for common base and common emitter configurations respectively). After initial tests have been made, the series resistors may be decreased and the voltage increased.
2. The use of high value capacitors must be avoided as far as possible. If their use cannot be avoided, series resistors of a few ohms must be inserted.

OPERATION

1. Input power
While the circuit is not optimized, it is recommended that the power input should be at a lower level than that specified.
2. Output waveform
It is advisable to check the output waveform with a spectrum analyzer or similar equipment to ensure that no parasitic effects are introduced by the power supply or earth (ground) connections, thus causing unwanted modulation.
3. Junction temperature
If the circuit design is likely to cause a large temperature rise, it is advisable to check the temperature rise with a pulsed input before applying full power.

N-P-N MICROWAVE TRANSISTOR

The BFQ33 is a small-signal silicon planar epitaxial transistor in a miniature hermetically sealed microstripline encapsulation, featuring an extremely high transition frequency and very low noise up to high frequencies.

It is primarily intended for use in microwave amplifier applications.

QUICK REFERENCE DATA

Collector-base voltage (open emitter)	V_{CBO}	max.	9 V
Collector-emitter voltage (open base)	V_{CEO}	max.	7 V
Collector current (d.c.)	I_C	max.	20 mA
Total power dissipation up to $T_{amb} = 80^\circ C$	P_{tot}	max.	140 mW
Transition frequency at $f = 1,5$ GHz $I_C = 14$ mA; $V_{CE} = 5$ V	f_T	typ.	12 GHz
Noise figure at optimum source impedance $I_C = 5$ mA; $V_{CE} = 5$ V; $f = 2$ GHz	N_o	typ.	2,5 dB
Maximum unilateral power gain (see page 3) $I_C = 14$ mA; $V_{CE} = 5$ V; $f = 2$ GHz; $T_{amb} = 25^\circ C$	GUM	typ.	13,7 dB

This data must be read in conjunction with GENERAL SAFETY RECOMMENDATIONS – MICROWAVE SEMICONDUCTORS

MECHANICAL DATA

Dimensions in mm

Fig.1 SOT-100, (metallized lid connected to emitter)

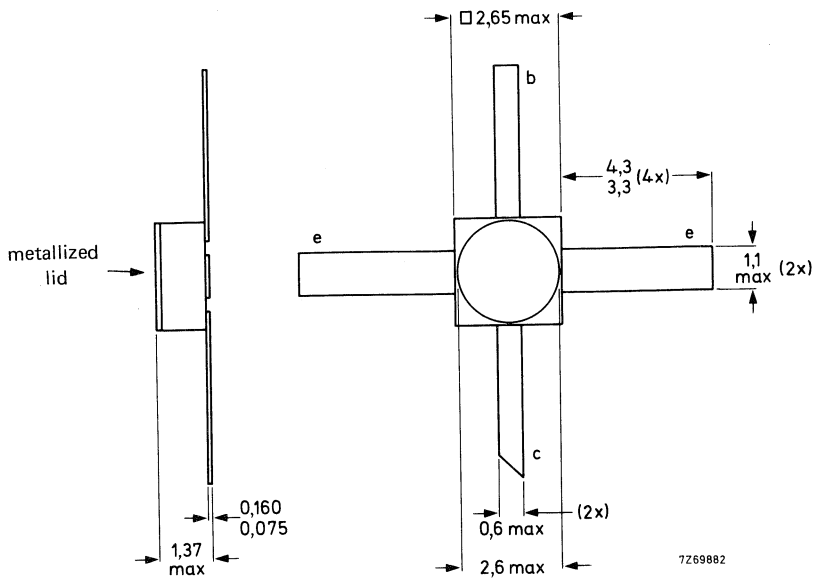

RATINGS

Limiting values in accordance with the Absolute Maximum System (IEC 134)

Collector-base voltage (open emitter)	V_{CB0}	max.	9 V
Collector-emitter voltage (open base)	V_{CEO}	max.	7 V
Emitter-base voltage (open collector)	V_{EBO}	max.	2 V
Collector current (d.c.)	I_C	max.	20 mA
Total power dissipation up to $T_{amb} = 80\text{ }^\circ\text{C}$	P_{tot}	max.	140 mW
Storage temperature	T_{stg}		-65 to +150 $^\circ\text{C}$
Junction temperature	T_j	max.	150 $^\circ\text{C}$

THERMAL RESISTANCE

From junction to ambient in free air
 mounted on a fibre-glass print
 of 40 mm x 25 mm x 1 mm

$$R_{th\ j-a} = 500\text{ }^\circ\text{C/W}$$

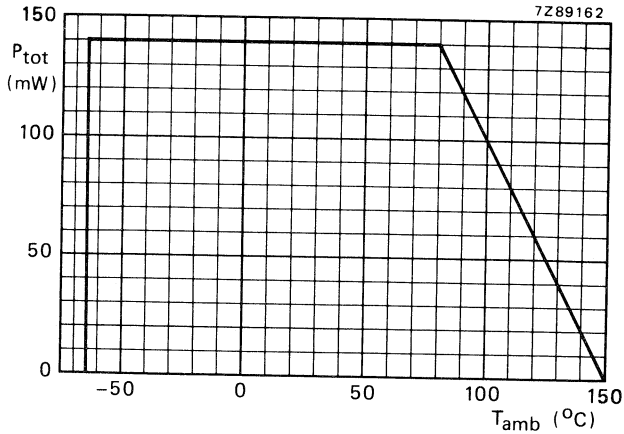

Fig. 2 Power derating curve versus ambient temperature.

CHARACTERISTICS

$T_{amb} = 25^{\circ}C$ unless otherwise specified

Collector cut-off current
 $I_E = 0; V_{CB} = 5 V$ $I_{CBO} < 50 \text{ nA}$

D.C. current gain *
 $I_C = 14 \text{ mA}; V_{CE} = 5 V$ $h_{FE} > 25$

Collector capacitance at $f = 1 \text{ MHz}$
 $I_E = I_e = 0; V_{CB} = 5 V$ $C_c \text{ typ. } 0,45 \text{ pF}$

Feedback capacitance at $f = 1 \text{ MHz}$
 $I_C = 0; V_{CE} = 5 V$ $C_{re} \text{ typ. } 0,2 \text{ pF}$

Transition frequency at $f = 1,5 \text{ GHz}^*$
 $I_C = 14 \text{ mA}; V_{CE} = 5 V$ $f_T \text{ typ. } 12 \text{ GHz}$

Noise figure at optimum source impedance
 $I_C = 5 \text{ mA}; V_{CE} = 5 V; f = 2 \text{ GHz}$ $N_o \text{ typ. } 2,5 \text{ dB}$

$I_C = 5 \text{ mA}; V_{CE} = 5 V; f = 4 \text{ GHz}$ $N_o \text{ typ. } 3,8 \text{ dB}$

Maximum unilateral power gain (s_{re} assumed to be zero)

$$G_{UM} \text{ (in dB)} = 10 \log \frac{|s_{fe}|^2}{(1 - |s_{ie}|^2)(1 - |s_{oe}|^2)}$$

$I_C = 14 \text{ mA}; V_{CE} = 5 V; f = 2 \text{ GHz}$ $G_{UM} \text{ typ. } 13,7 \text{ dB}$

$I_C = 14 \text{ mA}; V_{CE} = 5 V; f = 4 \text{ GHz}$ $G_{UM} \text{ typ. } 7,4 \text{ dB}$

s-parameters (common emitter)

$I_C = 14 \text{ mA}; V_{CE} = 5 V; R_S = R_L = 50 \Omega; f = 2 \text{ GHz}$

Input reflection coefficient	s_{ie}	typ.	0,18/ -155°
Reverse transmission coefficient	s_{re}	typ.	0,10/ +49°
Forward transmission coefficient	s_{fe}	typ.	4,3 / +75°
Output reflection coefficient	s_{oe}	typ.	0,43/ -56°

$I_C = 14 \text{ mA}; V_{CE} = 5 V; R_S = R_L = 50 \Omega; f = 4 \text{ GHz}$

Input reflection coefficient	s_{ie}	typ.	0,19/+ 171°
Reverse transmission coefficient	s_{re}	typ.	0,14/ +34°
Forward transmission coefficient	s_{fe}	typ.	2,0 / +48°
Output reflection coefficient	s_{oe}	typ.	0,50/ -89°

* Measured under pulse conditions.

Conditions for Figs 3 and 4:

$V_{CE} = 5 \text{ V}; I_C = 14 \text{ mA};$

$T_{amb} = 25 \text{ }^\circ\text{C}.$

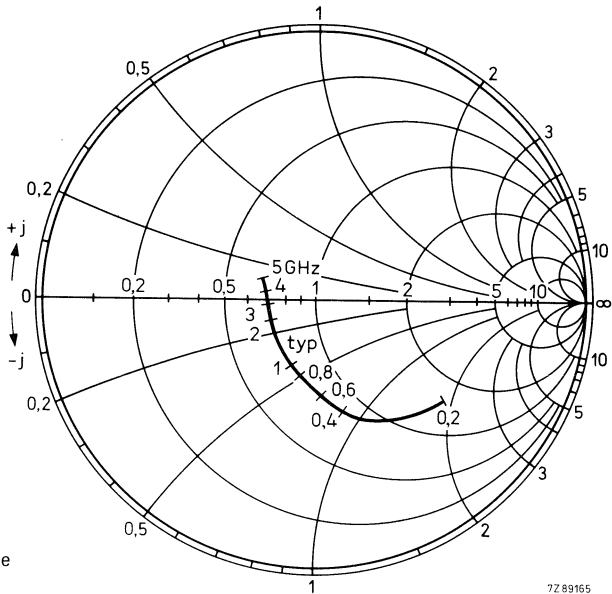

Fig. 3 Input impedance derived from input reflection coefficient s_{ie} co-ordinates in ohm x 50.

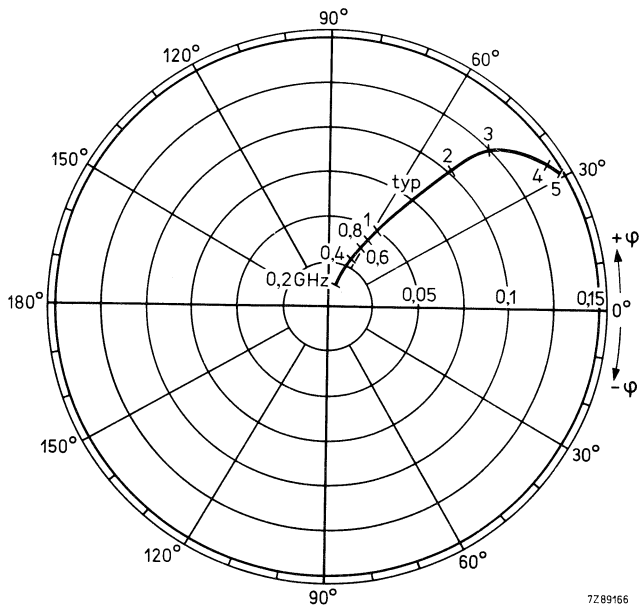

Fig. 4 Reverse transmission coefficient s_{re} .

Conditions for Figs 5 and 6:

$V_{CE} = 5 \text{ V}; I_C = 14 \text{ mA};$

$T_{amb} = 25 \text{ }^\circ\text{C}.$

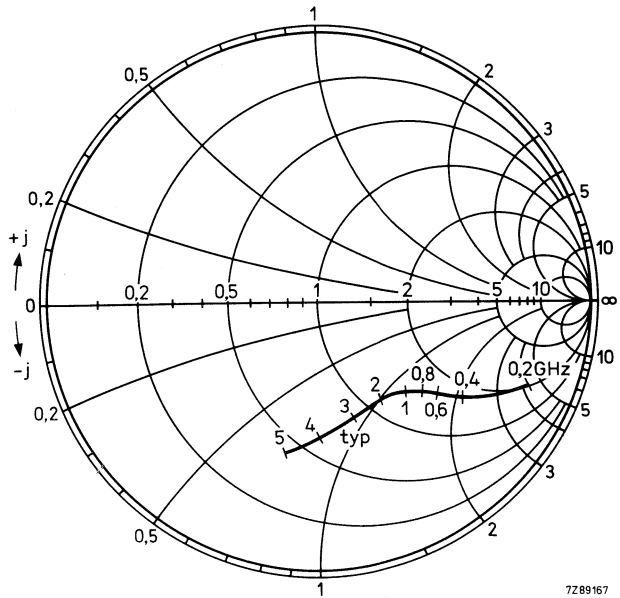

Fig. 5 Output impedance derived from output reflection coefficient s_{OE} co-ordinates in ohm $\times 50$.

7289167

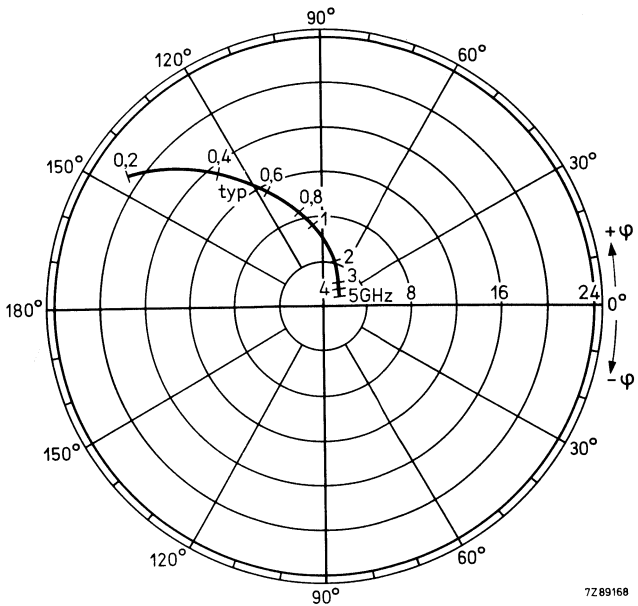

Fig. 6 Forward transmission coefficient s_{fe} .

7289168

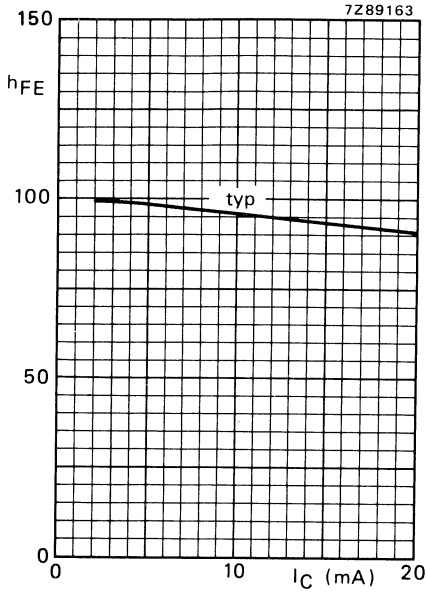

Fig. 7 $V_{CE} = 5\text{ V}$; $T_j = 25\text{ }^\circ\text{C}$.

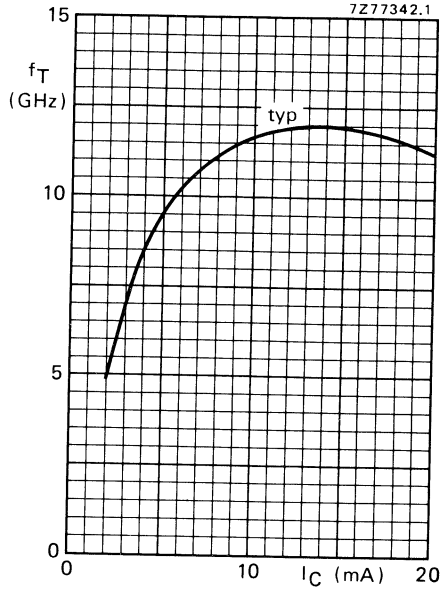

Fig. 8 $V_{CE} = 5\text{ V}$; $f = 1,5\text{ GHz}$; $T_j = 25\text{ }^\circ\text{C}$.

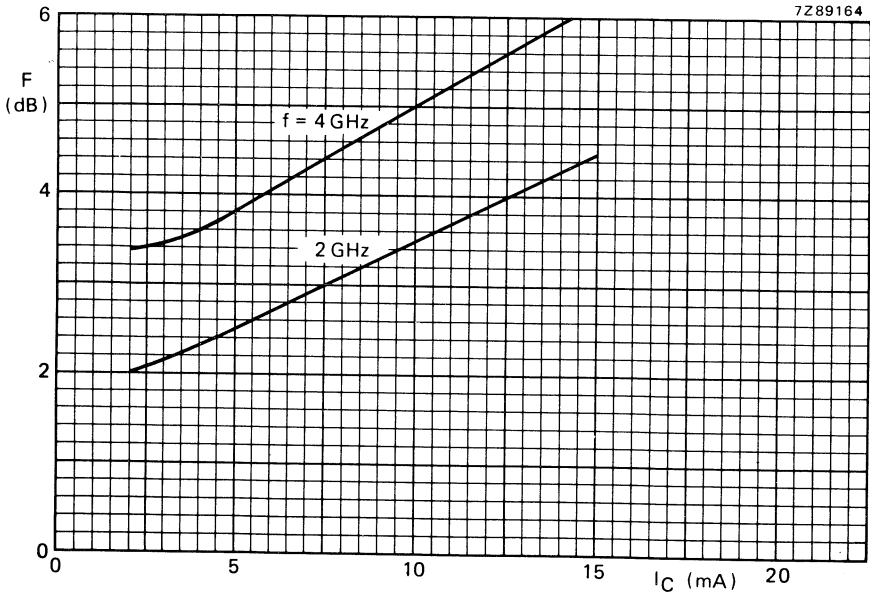

Fig. 9 $V_{CE} = 5\text{ V}$; $Z_S = \text{optimum}$; $T_{amb} = 25\text{ }^\circ\text{C}$; typical values.

N-P-N SILICON MICROWAVE TRANSISTOR

The BFR49 is a microwave transistor featuring a high transition frequency and low noise. A miniature ceramic encapsulation is used for compatibility with stripline and microwave circuits. It is suitable for amplifiers up to S-band frequencies in instrumentation and microwave systems.

QUICK REFERENCE DATA

Collector-base voltage (open emitter)	V_{CBO}	max	20 V
Collector-emitter voltage (open base)	V_{CEO}	max	15 V
Collector current (d.c.)	I_C	max	25 mA
Total power dissipation up to $T_{amb} = 110\text{ }^\circ\text{C}$	P_{tot}	max	180 mW
Transition frequency $I_C = 14\text{ mA}; V_{CE} = 10\text{ V}$	f_T	typ	5 GHz
Noise figure at optimum source impedance $I_C = 2\text{ mA}; V_{CE} = 10\text{ V}; f = 1\text{ GHz}$	N_o	typ	2,5 dB
Transducer power gain $I_C = 14\text{ mA}; V_{CE} = 10\text{ V}; f = 1\text{ GHz}$	$ s_{fe} ^2$	typ	15,5 dB

This data must be read in conjunction with GENERAL SAFETY RECOMMENDATIONS – MICROWAVE SEMICONDUCTORS

MECHANICAL DATA

SOT-100, (metallized lid connected to emitter)

Dimensions in mm

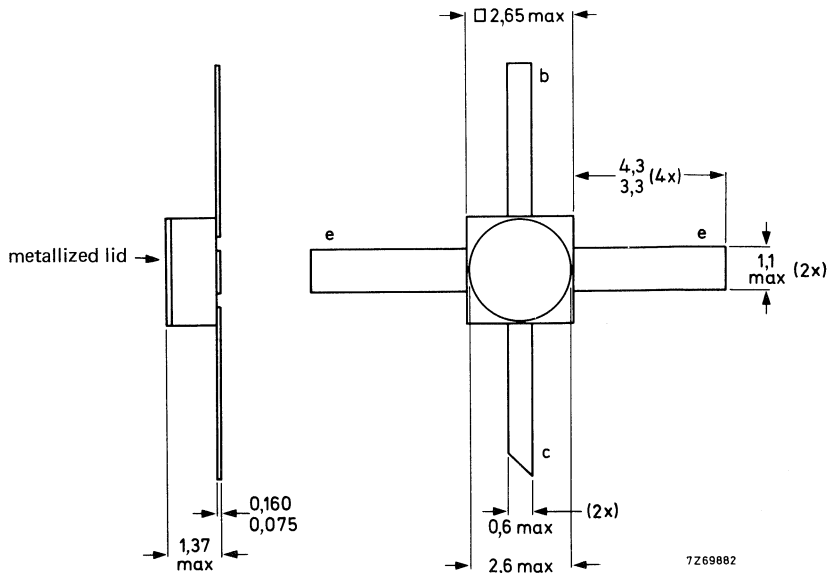

RATINGS

Limiting values in accordance with the Absolute Maximum System (IEC 134)

Collector-base voltage (open emitter; $I_C = 10 \mu A$)	V_{CBO}	max	20 V
Collector-emitter voltage (open base; $I_C = 10 mA$)	V_{CEO}	max	15 V
Emitter-base voltage (open collector; $I_E = 10 \mu A$)	V_{EBO}	max	2 V
Collector current (d.c.)	I_C	max	25 mA
Total power dissipation up to $T_{amb} = 110 \text{ }^\circ C$	P_{tot}	max	180 mW
Storage temperature	T_{stg}		-65 to +200 $^\circ C$
Junction temperature	T_j	max	200 $^\circ C$

THERMAL RESISTANCE

From junction to ambient in free air
mounted on a fibre-glass print
of 40 mm x 25 mm x 1 mm

$$R_{th j-a} = 0,5 \text{ }^\circ C/mW$$

CHARACTERISTICS

$T_{amb} = 25 \text{ }^\circ C$ unless otherwise specified

Collector cut-off current

$$I_E = 0; V_{CB} = 10 V$$

$$I_{CBO} < 50 \text{ nA}$$

D.C. current gain *

$$I_C = 14 \text{ mA}; V_{CE} = 10 V$$

$$h_{FE} > 25$$

Transition frequency *

$$I_C = 14 \text{ mA}; V_{CE} = 10 V; f = 500 \text{ MHz}$$

$$f_T \text{ typ } 5 \text{ GHz}$$

Collector capacitance at $f = 1 \text{ MHz}$

$$I_E = I_e = 0; V_{CB} = 10 V$$

$$C_c \text{ typ } 0,35 \text{ pF}$$

Emitter capacitance at $f = 1 \text{ MHz}$

$$I_C = I_c = 0; V_{EB} = 0,5 V$$

$$C_e \text{ typ } 1,1 \text{ pF}$$

Feedback capacitance at $f = 1 \text{ MHz}$

$$I_C = 2 \text{ mA}; V_{CE} = 10 V$$

$$C_{re} \text{ typ } 0,3 \text{ pF}$$

Noise figure at optimum source impedance

$$I_C = 2 \text{ mA}; V_{CE} = 10 V; f = 1 \text{ GHz}$$

$$N_o \text{ typ } 2,5 \text{ dB}$$

$$I_C = 2 \text{ mA}; V_{CE} = 10 V; f = 4 \text{ GHz}$$

$$N_o \text{ typ } 6,5 \text{ dB}$$

Maximum unilateral power gain (s_{re} assumed to be zero)

$$G_{UM} \text{ (in dB)} = 10 \log \frac{|s_{fe}|^2}{(1 - |s_{ie}|^2)(1 - |s_{oe}|^2)}$$

$$I_C = 14 \text{ mA}; V_{CE} = 10 V; f = 1 \text{ GHz}$$

$$G_{UM} \text{ typ } 17,0 \text{ dB}$$

$$I_C = 14 \text{ mA}; V_{CE} = 10 V; f = 4 \text{ GHz}$$

$$G_{UM} \text{ typ } 6,5 \text{ dB}$$

Transducer power gain

$$I_C = 14 \text{ mA}; V_{CE} = 10 V; f = 1 \text{ GHz}$$

$$|s_{fe}|^2 \text{ typ } 15,5 \text{ dB}$$

$$I_C = 14 \text{ mA}; V_{CE} = 10 V; f = 4 \text{ GHz}$$

$$|s_{fe}|^2 \text{ typ } 3,5 \text{ dB}$$

* Measured under pulse conditions.

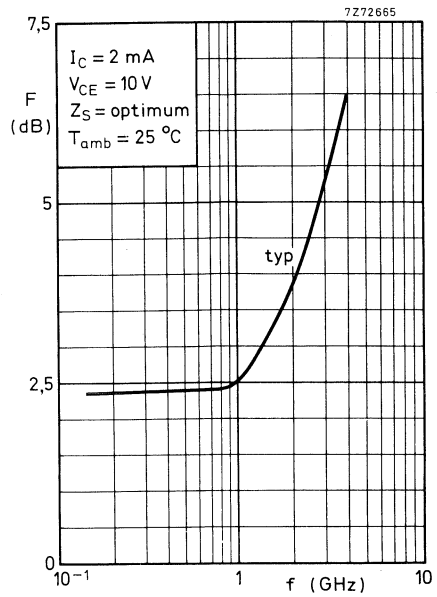
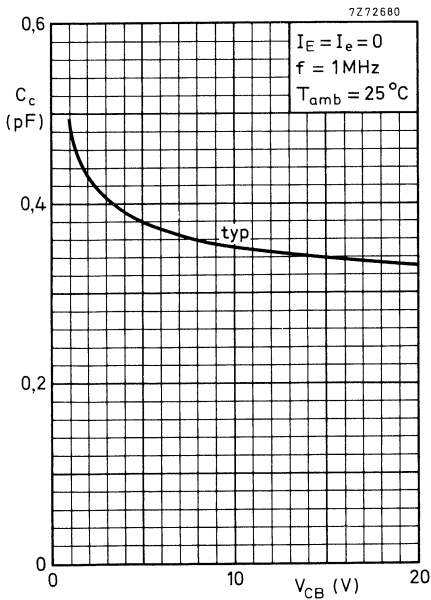
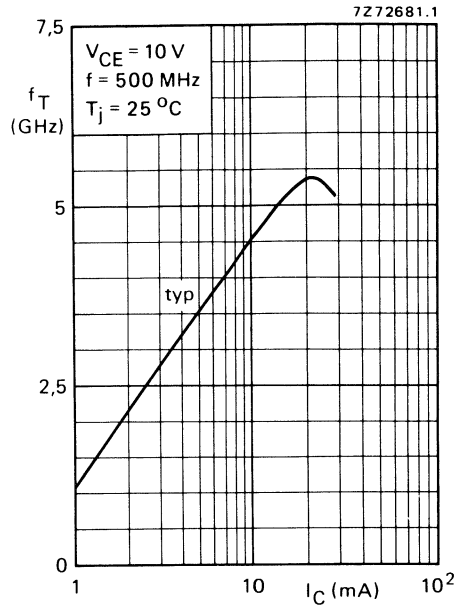
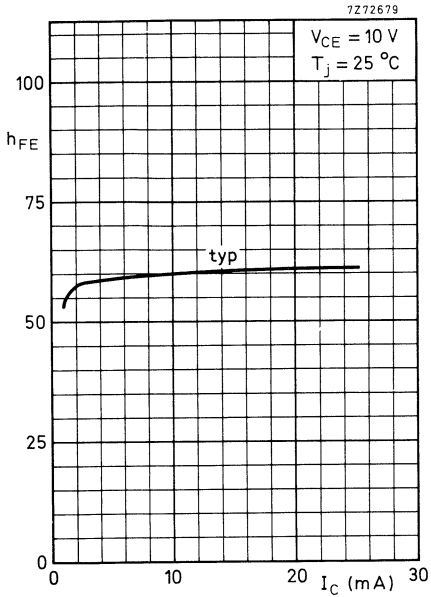

BFR49

$V_{CE} = 10 \text{ V}$
 $I_C = 14 \text{ mA}$
 $T_{amb} = 25 \text{ }^\circ\text{C}$

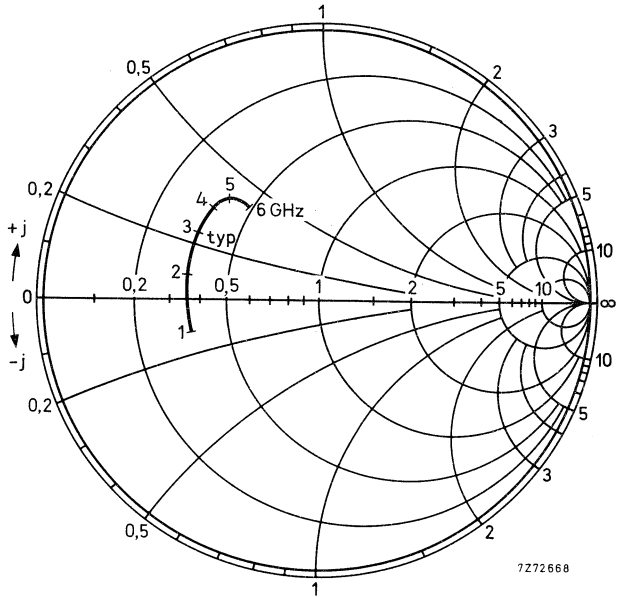

Input impedance derived from
 input reflection coefficient s_{ie}
 co-ordinates in ohm $\times 50$.



$V_{CE} = 10 \text{ V}$
 $I_C = 14 \text{ mA}$
 $T_{amb} = 25 \text{ }^\circ\text{C}$

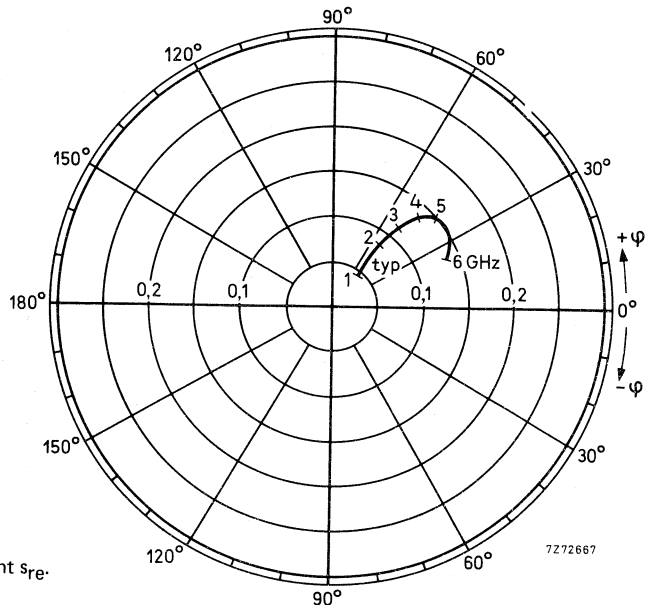

Reverse transmission coefficient s_{re} .

$V_{CE} = 10\text{ V}$
 $I_C = 14\text{ mA}$
 $T_{amb} = 25\text{ }^\circ\text{C}$

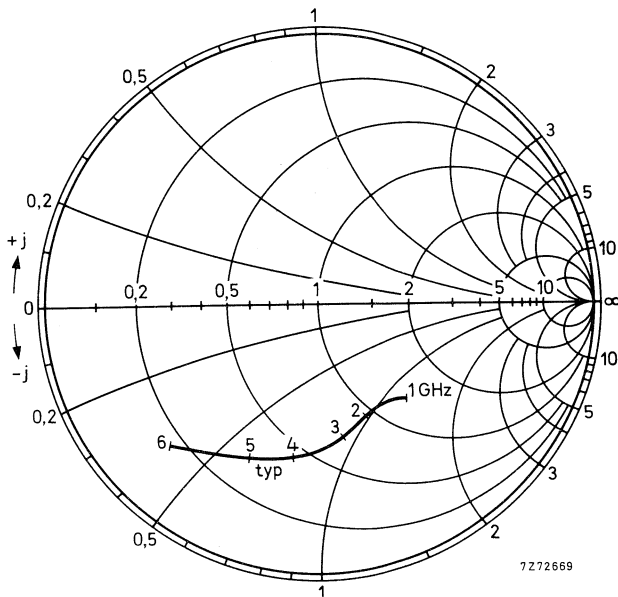

Output impedance derived from output reflection coefficient s_{oe} co-ordinates in ohm $\times 50$.

7Z72669

$V_{CE} = 10\text{ V}$
 $I_C = 14\text{ mA}$
 $T_{amb} = 25\text{ }^\circ\text{C}$

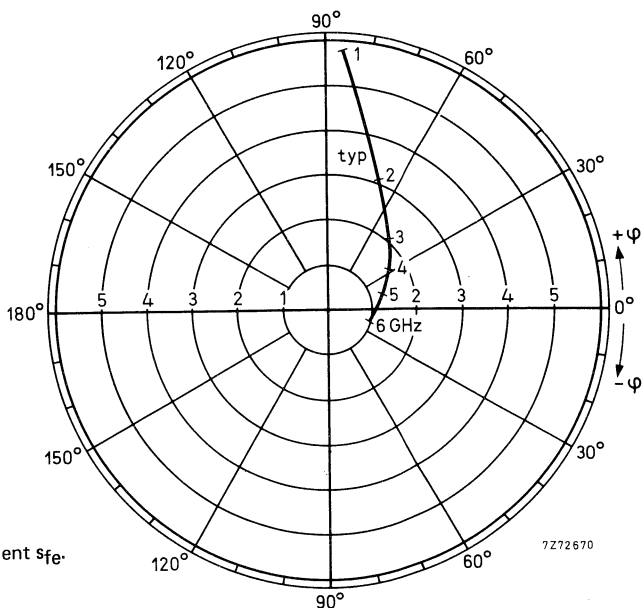

Forward transmission coefficient s_{fe} .

7Z72670

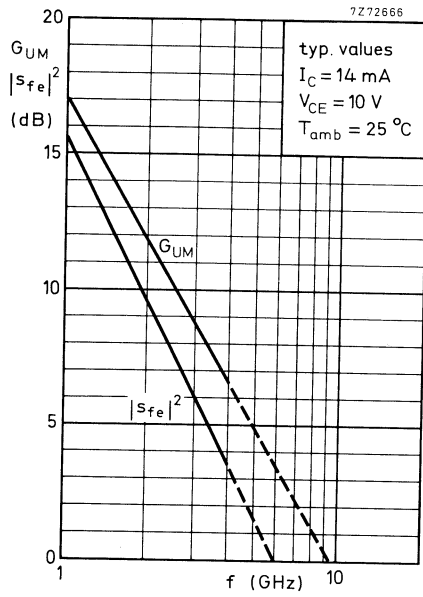

MICROWAVE LINEAR POWER TRANSISTOR

N-P-N transistor for common-emitter class-A linear power amplifiers up to 4 GHz. Self-aligned process entirely ion implanted and gold sandwich metallization ensure an optimum temperature profile, excellent performance and reliability.

A miniature ceramic encapsulation is used for compatibility with stripline and microwave circuits.

QUICK REFERENCE DATA

R.F. performance up to $T_{\text{case}} = 25\text{ }^{\circ}\text{C}$ in an unneutralized common-emitter class-A circuit

mode of operation	f GHz	V_{CE} V	I_{C} mA	P_{L1} mW	G_{po} dB	\bar{z}_i Ω	\bar{z}_L Ω
c.w.; linear amplifier	4	15	25	typ. 110	typ. 9,5	typ. $7 + j22$	typ. $10 + j38$

This data must be read in conjunction with GENERAL SAFETY RECOMMENDATIONS – MICROWAVE SEMICONDUCTORS

MECHANICAL DATA

Dimensions in mm

Fig.1 SOT-100 (metallized lid connected to emitter)

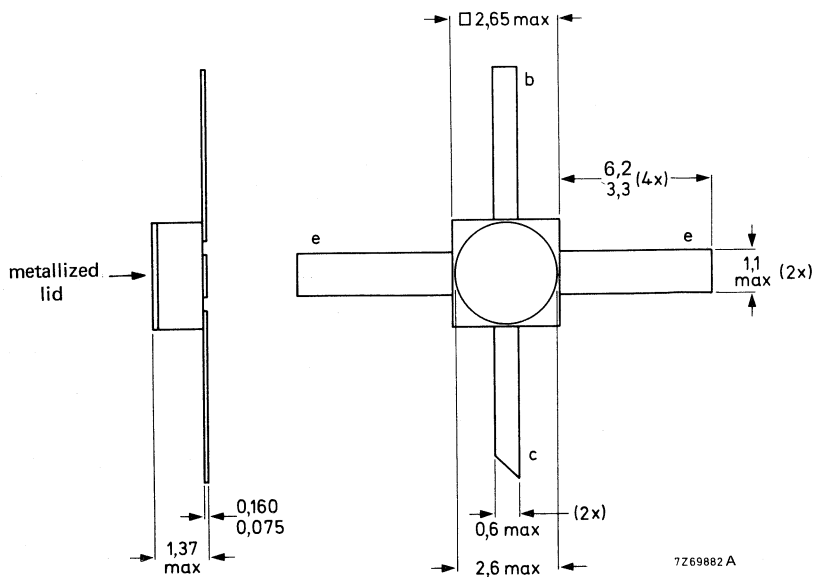

Marking code

R8 = LAE4001R

RATINGS

Limiting values in accordance with the Absolute Maximum System (IEC134).

Collector-base voltage (open emitter)	V_{CBO}	max.	30 V
Collector-emitter voltage ($R_{BE} = 220 \Omega$) (open base)	V_{CER}	max.	25 V
	V_{CEO}	max.	16 V
Emitter-base voltage (open collector)	V_{EBO}	max.	2 V
Collector current (d.c.)	I_C	max.	80 mA
Total power dissipation up to $T_{case} = 100^\circ C$	P_{tot}	max.	480 mW
Storage temperature	T_{stg}		-65 to +200 °C
Junction temperature	T_j	max.	200 °C
Lead soldering temperature at 0,1 mm from the case; $t_{sld} \leq 10$ s	T_{sld}	max.	235 °C

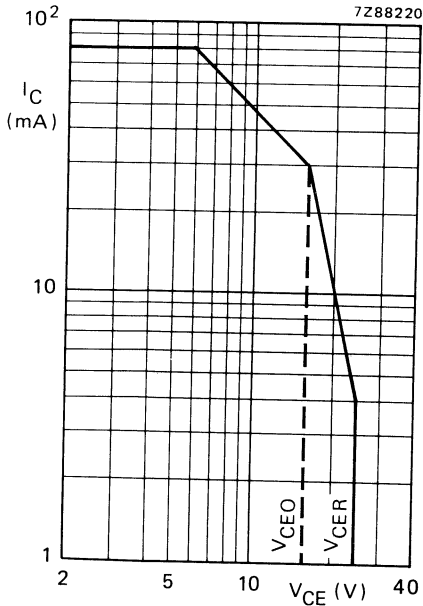

Fig. 2 D.C. SOAR at $T_{case} \leq 100^\circ C$;
 $R_{BE} < 220 \Omega$.

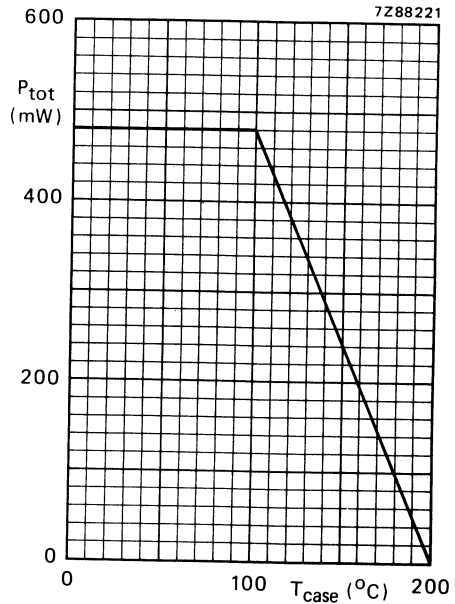

Fig. 3 Power derating curve vs. temperature.

THERMAL RESISTANCE

From junction to case

$R_{th j-c} = 210^\circ C/W$

CHARACTERISTICS

$T_{\text{case}} = 25\text{ }^{\circ}\text{C}$

Collector cut-off current

$I_E = 0; V_{CB} = 15\text{ V}$

$I_{CBO} < 100\text{ nA}$

$I_E = 0; V_{CB} = 30\text{ V}$

$I_{CBO} < 100\text{ }\mu\text{A}$

$V_{CB} = 25\text{ V}; R_{BE} = 220\text{ }\Omega$

$I_{CER} < 500\text{ }\mu\text{A}$

Emitter cut-off current

$I_C = 0; V_{EB} = 1,5\text{ V}$

$I_{EBO} < 35\text{ nA}$

$I_C = 0; V_{EB} = 2,0\text{ V}$

$I_{EBO} < 0,15\text{ }\mu\text{A}$

D.C. current gain

$I_C = 25\text{ mA}; V_{CE} = 5\text{ V}$

$h_{FE} \quad 20\text{ to }220$

Collector-base capacitance at $f = 1\text{ MHz}$

$I_E = I_C = 0; V_{CB} = 15\text{ V}; V_{EB} = 1,5\text{ V}$

$C_{cb} \quad \text{typ.} \quad 0,25\text{ pF}$

Collector-emitter capacitance at $f = 1\text{ MHz}$

$I_E = I_C = 0; V_{CE} = 15; V_{EB} = 1,5\text{ V}$

$C_{ce} \quad \text{typ.} \quad 0,5\text{ pF}$

Emitter-base capacitance at $f = 1\text{ MHz}$

$I_E = I_C = 0; V_{EB} = 1,0\text{ V}; V_{CB} = 15\text{ V}$

$C_{eb} \quad \text{typ.} \quad 1,3\text{ pF}$

Forward power gain

$I_C = 25\text{ mA}; V_{CE} = 15\text{ V}; f = 2\text{ GHz}$

$|S_{fe}|^2 \quad \text{typ.} \quad 9,6\text{ dB}$

$I_C = 25\text{ mA}; V_{CE} = 15\text{ V}; f = 4\text{ GHz}$

$|S_{fe}|^2 \quad \text{typ.} \quad 3,8\text{ dB}$

Maximum available gain

$I_C = 25\text{ mA}; V_{CE} = 15\text{ V}; f = 2\text{ GHz}$

$G_{AM} \quad \text{typ.} \quad 16\text{ dB}$

$I_C = 25\text{ mA}; V_{CE} = 15\text{ V}; f = 4\text{ GHz}$

$G_{AM} \quad \text{typ.} \quad 10\text{ dB}$



s-parameters (common emitter)

Typical values; $V_{CE} = 15 \text{ V}$; $I_C = 25 \text{ mA}$; $T_{\text{case}} = 25 \text{ }^\circ\text{C}$; $Z_0 = 50 \text{ } \Omega$

f MHz	s_{ie}	s_{re}	s_{fe}	s_{oe}
500	0,63/−165°	0,014(−37,1)/47°	10,7 (20,6)/ 101°	0,59/− 28°
600	0,64/−171°	0,015(−36,2)/47°	9,01(19,1)/ 96°	0,58/− 29°
700	0,65/−177°	0,018(−35,1)/47°	8,03(18,1)/ 89°	0,56/− 30°
800	0,65/ 180°	0,019(−34,5)/47°	7,08(17,0)/ 84°	0,55/− 31°
900	0,65/ 176°	0,021(−33,7)/48°	6,31(16,0)/ 80°	0,54/− 32°
1000	0,66/ 172°	0,023(−32,9)/49°	5,75(15,2)/ 76°	0,53/− 34°
1200	0,67/ 167°	0,026(−31,8)/50°	4,85(13,7)/ 69°	0,53/− 37°
1400	0,67/ 163°	0,030(−30,5)/50°	4,17(12,4)/ 62°	0,52/− 41°
1600	0,67/ 155°	0,034(−29,3)/50°	3,67(11,3)/ 56°	0,52/− 44°
1800	0,67/ 150°	0,038(−28,4)/51°	3,31(10,4)/ 50°	0,52/− 49°
2000	0,68/ 146°	0,043(−27,4)/50°	3,02(9,6)/ 45°	0,52/− 53°
2500	0,70/ 134°	0,053(−25,5)/47°	2,46(7,8)/ 31°	0,52/− 64°
3000	0,72/ 123°	0,064(−23,9)/43°	2,05(6,2)/ 18°	0,51/− 76°
3500	0,74/ 113°	0,075(−22,5)/38°	1,76(4,9)/ 3°	0,50/− 90°
4000	0,76/ 104°	0,085(−21,4)/33°	1,55(3,8)/ −11°	0,50/−105°
4500	0,77/ 95°	0,095(−20,4)/26°	1,37(2,7)/ −23°	0,51/−123°
5000	0,79/ 88°	0,107(−19,4)/19°	1,19(1,5)/ −35°	0,52/−141°
5500	0,80/ 81°	0,120(−18,4)/12°	1,06(0,5)/ −48°	0,57/−158°
6000	0,80/ 75°	0,133(−17,5)/ 6°	0,96(−0,4)/ −60°	0,62/−173°

The figures given between brackets are values in dB.

APPLICATION INFORMATION

R.F. performance up to $T_{case} = 25\text{ }^{\circ}\text{C}$ in an unneutralized common-emitter class-A circuit *

mode of operation	f GHz	$V_{CE}^{(1)}$ V	$I_C^{(1)}$ mA	$P_{L1}^{(2)}$ mW(dBm)	$G_{po}^{(3)}$ dB	\bar{Z}_i Ω	\bar{Z}_L Ω
c.w.; linear amplifier	4	15	25	> 85(19,3) typ. 110(20,4)	> 8,5 typ. 9,5	typ.7+j22	typ.10+j38

Notes

- 1 I_C and V_{CE} regulated.
- 2 Load power for 1 dB compressed power gain.
- 3 Low-level power gain associated with P_{L1} .

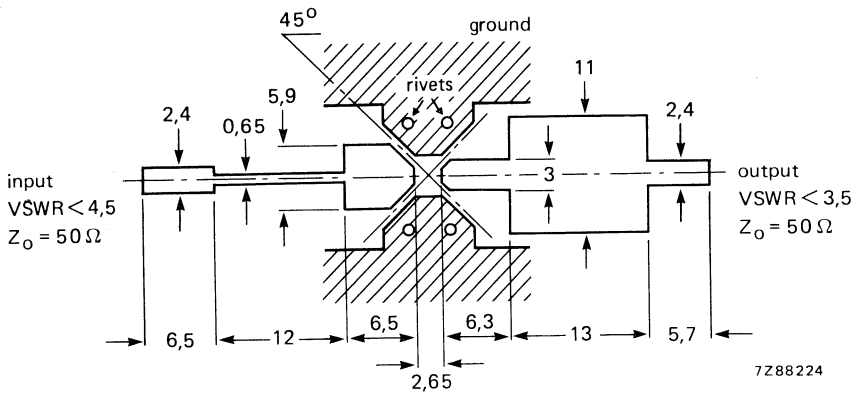

Fig. 4 Prematching test circuit board for 4 GHz. (Dimensions in mm.)

Striplines on a double Cu-clad printed-circuit board with PTFE fibre-glass dielectric ($\epsilon_r = 2,54$); thickness 0,8 mm.

* Circuit consists of prematching circuit board in combination with input and output slug tuners.

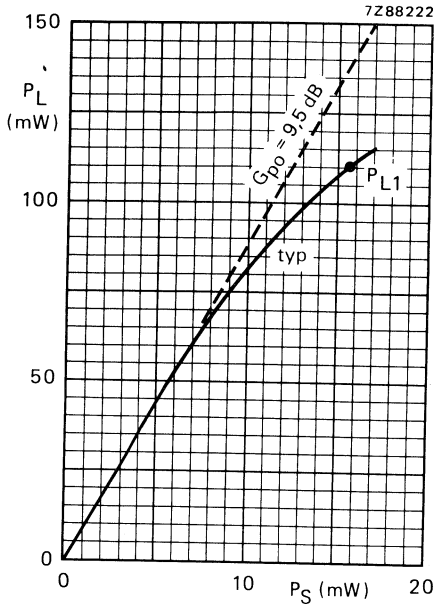

Fig. 5 $V_{CE} = 15 \text{ V}$; $I_C = 25 \text{ mA}$; $f = 4 \text{ GHz}$;
 $T_{case} = 25 \text{ }^\circ\text{C}$.

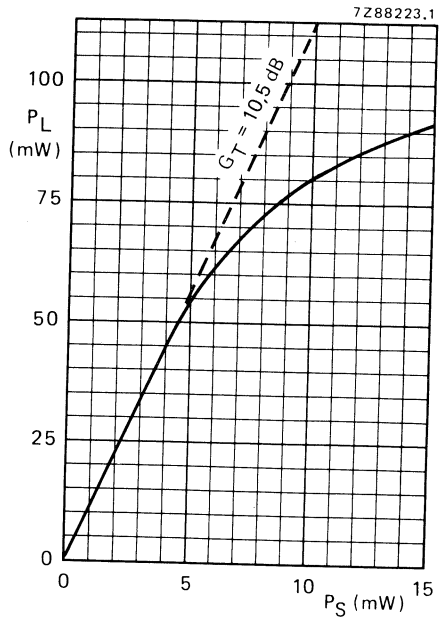

Fig. 6 $V_{CE} = 15 \text{ V}$; $I_C = 25 \text{ mA}$; $f = 4 \text{ GHz}$;
 maximum low-level linear power gain.



MICROWAVE LINEAR POWER TRANSISTOR

N-P-N transistor for common-emitter class-A linear power amplifiers up to 4 GHz. Diffused emitter ballasting resistors, self-aligned process entirely ion implanted and gold sandwich metallization ensure an optimum temperature profile, excellent performance and reliability.

A miniature ceramic encapsulation is used for compatibility with stripline and microwave circuits.

QUICK REFERENCE DATA

R.F. performance up to $T_{case} = 25\text{ }^{\circ}\text{C}$ in an unneutralized common-emitter class-A circuit

mode of operation	f GHz	V_{CE} V	I_C mA	P_{L1} mW	G_{po} dB	\bar{z}_i Ω	\bar{Z}_L Ω
c.w.; linear amplifier	4	18	30	typ. 160	typ. 8	typ. $4 + j23$	typ. $6,5 + j32$

MECHANICAL DATA

Dimensions in mm

Fig. 1 SOT-100.

Emitter connected to metallized lid

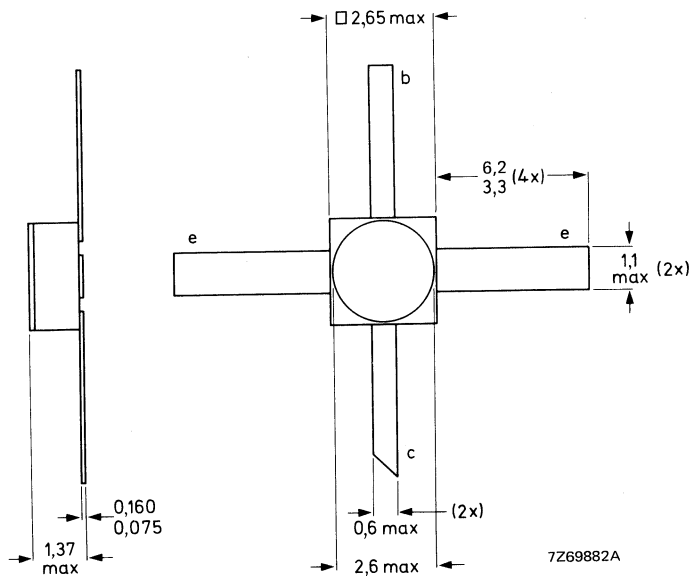

Marking code

R9 = LAE4002S

RATINGS

Limiting values in accordance with the Absolute Maximum System (IEC 134)

Collector-base voltage (open emitter)	V_{CBO}	max.	40 V
Collector-emitter voltage ($R_{BE} = 220 \Omega$) (open base)	V_{CER}	max.	35 V
	V_{CEO}	max.	16 V
Emitter-base voltage (open collector)	V_{EBO}	max.	3 V
Collector current (d.c.)	I_C	max.	90 mA
Total power dissipation up to $T_{case} = 75 \text{ }^\circ\text{C}$	P_{tot}	max.	625 mW
Storage temperature	T_{stg}		-65 to +200 $^\circ\text{C}$
Junction temperature	T_j	max.	200 $^\circ\text{C}$
Lead soldering temperature at 0,1 mm from the case; $t_{sld} \leq 10 \text{ s}$	T_{sld}	max.	235 $^\circ\text{C}$

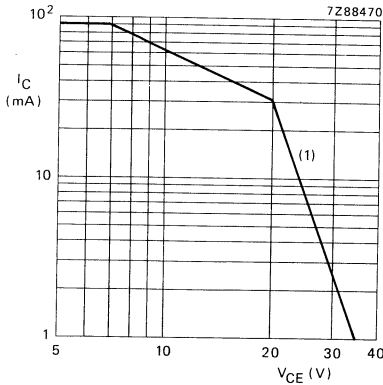

(1) Second breakdown limit (independent of temperature).

Fig. 2 D.C. SOAR at $T_{case} \leq 75 \text{ }^\circ\text{C}$;
 $R_{BE} < 220 \Omega$.

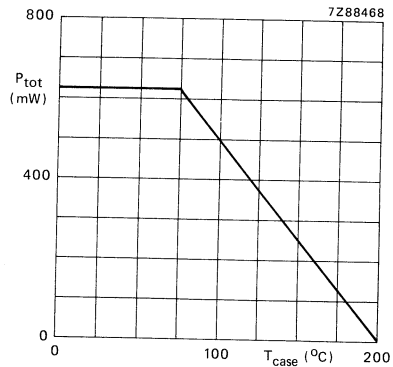

Fig. 3 Power derating curve vs. temperature.

THERMAL RESISTANCE

From junction to case

$$R_{th\ j-c} = 200 \text{ }^\circ\text{C/W}$$

CHARACTERISTICS

 $T_{\text{case}} = 25\text{ }^{\circ}\text{C}$

Collector cut-off current

$I_E = 0; V_{CB} = 20\text{ V}$

$I_E = 0; V_{CB} = 40\text{ V}$

$V_{CB} = 35\text{ V}; R_{BE} = 220\text{ }\Omega$

Emitter cut-off current

$I_C = 0; V_{EB} = 1,5\text{ V}$

$I_C = 0; V_{EB} = 3,0\text{ V}$

D.C. current gain

$I_C = 30\text{ mA}; V_{CE} = 5\text{ V}$

Collector-base capacitance at $f = 1\text{ MHz}$

$I_E = I_C = 0; V_{CB} = 18\text{ V}; V_{EB} = 1,5\text{ V}$

Collector-emitter capacitance at $f = 1\text{ MHz}$

$I_E = I_C = 0; V_{CE} = 18\text{ V}; V_{EB} = 1,5\text{ V}$

Emitter-base capacitance at $f = 1\text{ MHz}$

$I_E = I_C = 0; V_{EB} = 1,0\text{ V}; V_{CB} = 18\text{ V}$

Forward power gain

$I_C = 30\text{ mA}; V_{CE} = 18\text{ V}; f = 2\text{ GHz}$

$I_C = 30\text{ mA}; V_{CE} = 18\text{ V}; f = 4\text{ GHz}$

Maximum available gain

$I_C = 30\text{ mA}; V_{CE} = 18\text{ V}; f = 2\text{ GHz}$

$I_C = 30\text{ mA}; V_{CE} = 18\text{ V}; f = 3\text{ GHz}$

$I_{CBO} < 100\text{ nA}$

$I_{CBO} < 150\text{ }\mu\text{A}$

$I_{CER} < 500\text{ }\mu\text{A}$

$I_{EBO} < 50\text{ nA}$

$I_{EBO} < 25\text{ }\mu\text{A}$

$h_{FE} \quad 15\text{ to }150$

$C_{cb} \quad \text{typ.} \quad 0,3\text{ pF}$

$C_{ce} \quad \text{typ.} \quad 0,55\text{ pF}$

$C_{eb} \quad \text{typ.} \quad 1,8\text{ pF}$

$|s_{fe}|^2 \quad \text{typ.} \quad 8,8\text{ dB}$

$|s_{fe}|^2 \quad \text{typ.} \quad 2,8\text{ dB}$

$G_{AM} \quad \text{typ.} \quad 14\text{ dB}$

$G_{AM} \quad \text{typ.} \quad 11\text{ dB}$



LAE4002S

s-parameters (common emitter)

Typical values; $V_{CE} = 18 \text{ V}$; $I_C = 30 \text{ mA}$; $T_{case} = 25 \text{ }^\circ\text{C}$; $Z_o = 50 \text{ } \Omega$

f MHz	S_{ie}	S_{re}	S_{fe}	S_{oe}
500	0,63/−153°	0,023(−32,7)/38°	9,89(19,9)/ 98°	0,55/ −34°
600	0,63/−161°	0,024(−32,2)/38°	8,22(18,3)/ 94°	0,53/ −35°
700	0,63/−168°	0,026(−31,6)/38°	7,33(17,3)/ 87°	0,51/ −36°
800	0,64/−173°	0,028(−30,9)/38°	6,46(16,2)/ 82°	0,50/ −37°
900	0,64/−177°	0,030(−30,4)/38°	5,82(15,3)/ 78°	0,50/ −38°
1000	0,64/ 179°	0,032(−29,9)/40°	5,25(14,4)/ 74°	0,49/ −40°
1200	0,64/ 172°	0,035(−29,0)/40°	4,47(13,0)/ 66°	0,48/ −44°
1400	0,65/ 165°	0,039(−28,1)/41°	3,80(11,6)/ 59°	0,48/ −49°
1600	0,65/ 159°	0,044(−27,1)/41°	3,35(10,5)/ 52°	0,48/ −53°
1800	0,65/ 154°	0,048(−26,3)/41°	3,02(9,6)/ 46°	0,48/ −59°
2000	0,66/ 147°	0,053(−25,5)/40°	2,75(8,8)/ 40°	0,48/ −64°
2500	0,67/ 134°	0,064(−23,9)/37°	2,24(7,0)/ 25°	0,48/ −77°
3000	0,70/ 122°	0,076(−22,4)/33°	1,84(5,3)/ 11°	0,48/ −91°
3500	0,71/ 111°	0,088(−21,1)/28°	1,58(4,0)/ −4°	0,48/ −108°
4000	0,73/ 101°	0,101(−19,9)/22°	1,38(2,8)/−12°	0,50/−125°
4500	0,75/ 92°	0,112(−19,0)/ 16°	1,21(1,7)/−32°	0,52/−143°
5000	0,76/ 85°	0,125(−18,1)/ 8°	1,05(0,4)/−45°	0,56/−161°
5500	0,77/ 78°	0,138(−17,2)/ 2°	0,92(−0,7)/−58°	0,61/−178°
6000	0,77/ 71°	0,150(−16,5)/−4°	0,81(−1,8)/−69°	0,67/ 168°

Typical values; $V_{CE} = 15 \text{ V}$; $I_C = 15 \text{ mA}$; $T_{case} = 25 \text{ }^\circ\text{C}$; $Z_o = 50 \text{ } \Omega$

f MHz	S_{ie}	S_{re}	S_{fe}	S_{oe}
500	0,63/−145°	0,030(−30,5)/36°	9,22(19,3)/103°	0,58/ −38°
600	0,63/−154°	0,031(−30,1)/35°	7,76(17,8)/ 97°	0,56/ −39°
700	0,63/−161°	0,033(−29,6)/33°	6,92(16,8)/ 90°	0,52/ −40°
800	0,64/−167°	0,035(−29,2)/33°	6,16(15,8)/ 85°	0,51/ −41°
900	0,64/−172°	0,036(−28,8)/32°	5,56(14,9)/ 81°	0,50/ −42°
1000	0,64/−177°	0,038(−28,4)/32°	5,01(14,0)/ 76°	0,49/ −44°
1200	0,65/ 176°	0,041(−27,8)/33°	4,26(12,6)/ 68°	0,48/ −48°
1400	0,65/ 170°	0,045(−27,0)/36°	3,67(11,3)/ 61°	0,47/ −53°
1600	0,65/ 162°	0,048(−26,3)/34°	3,23(10,2)/ 55°	0,47/ −57°
1800	0,65/ 157°	0,052(−25,7)/35°	2,92(9,3)/ 48°	0,47/ −63°
2000	0,66/ 149°	0,056(−25,0)/33°	2,66(8,5)/ 42°	0,47/ −67°
2500	0,67/ 136°	0,066(−23,6)/32°	2,14(6,6)/ 26°	0,47/ −80°
3000	0,69/ 124°	0,076(−22,3)/28°	1,78(5,0)/ 12°	0,47/ −95°
3500	0,71/ 112°	0,089(−21,0)/24°	1,53(3,7)/ −2°	0,47/−112°
4000	0,73/ 102°	0,100(−20,0)/20°	1,29(2,2)/−17°	0,49/−130°
4500	0,75/ 93°	0,112(−19,0)/13°	1,16(1,3)/−31°	0,52/−148°
5000	0,76/ 86°	0,125(−18,1)/ 6°	1,01(0,1)/−43°	0,56/−166°
5500	0,77/ 78°	0,136(−17,3)/ 0°	0,88(−1,1)/−56°	0,61/−177°
6000	0,77/ 72°	0,148(−16,6)/−7°	0,79(−2,1)/−67°	0,67/ 168°

The figures given between brackets are values in dB.

s-parameters (common emitter)

Typical values; $V_{CE} = 18 \text{ V}$; $I_C = 10 \text{ mA}$; $T_{\text{case}} = 25 \text{ }^\circ\text{C}$; $Z_0 = 50 \text{ } \Omega$

f MHz	S_{ie}	S_{re}	S_{fe}	S_{oe}
500	0,65/ -135°	0,032(-29,8)/ 34°	8,41(18,5)/ 105°	0,64/ -34°
600	0,65/ -147°	0,033(-29,5)/ 33°	7,16(17,1)/ 100°	0,62/ -36°
700	0,65/ -154°	0,036(-28,9)/ 30°	6,46(16,2)/ 92°	0,59/ -37°
800	0,65/ -161°	0,037(-28,6)/ 29°	5,68(15,1)/ 87°	0,57/ -38°
900	0,65/ -166°	0,038(-28,3)/ 28°	5,13(14,2)/ 82°	0,56/ -40°
1000	0,65/ -172°	0,040(-28,0)/ 28°	4,68(13,4)/ 78°	0,55/ -42°
1200	0,65/ 180°	0,042(-27,5)/ 29°	3,98(12,0)/ 69°	0,54/ -46°
1400	0,65/ 174°	0,045(-27,0)/ 29°	3,43(10,7)/ 62°	0,53/ -50°
1600	0,65/ 165°	0,048(-26,4)/ 29°	3,06(9,7)/ 55°	0,53/ -55°
1800	0,66/ 159°	0,051(-25,9)/ 30°	2,75(8,8)/ 48°	0,53/ -61°
2000	0,67/ 152°	0,054(-25,4)/ 30°	2,49(7,9)/ 42°	0,53/ -65°
2500	0,68/ 138°	0,063(-24,1)/ 29°	2,02(6,1)/ 25°	0,53/ -78°
3000	0,69/ 125°	0,072(-22,8)/ 27°	1,67(4,5)/ 12°	0,52/ -93°
3500	0,71/ 114°	0,083(-21,6)/ 24°	1,44(3,2)/ -4°	0,53/ -109°
4000	0,74/ 103°	0,095(-20,4)/ 20°	1,26(2,0)/ -19°	0,55/ -127°
4500	0,75/ 94°	0,106(-19,5)/ 14°	1,10(0,8)/ -32°	0,57/ -145°
5000	0,76/ 86°	0,118(-18,6)/ 7°	0,94(-0,5)/ -44°	0,61/ -163°
5500	0,77/ 79°	0,132(-17,6)/ 0°	0,83(-1,7)/ -57°	0,65/ -179°
6000	0,77/ 72°	0,145(-16,8)/ -6°	0,72(-2,8)/ -68°	0,71/ 168°

The figures given between brackets are values in dB.



APPLICATION INFORMATION

R.F. performance up to $T_{case} = 25\text{ }^{\circ}\text{C}$ in an unneutralized common-emitter class-A circuit*

mode of operation	f GHz	$V_{CE}^{(1)}$ V	$I_C^{(1)}$ mA	$P_{L1}^{(2)}$ mW(dBm)	$G_{po}^{(3)}$ dB	\bar{z}_i Ω	\bar{z}_L Ω
c.w.; linear amplifier	4	18	30	> 126(21) typ. 160(22)	> 7,5 typ. 8,0	typ. $4 + j23$	typ. $6,5 + j32$

Notes

1. I_C and V_{CE} regulated.
2. Load power for 1 dB compressed power gain.
3. Low-level power gain associated with P_{L1} .

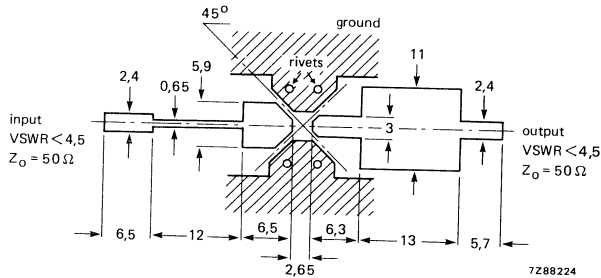

Fig. 4 Prematching test circuit board for 4 GHz. (Dimensions in mm.)

Striplines on a double Cu-clad printed-circuit board with PTFE fibre-glass dielectric ($\epsilon_r = 2,54$); thickness 0,8 mm.

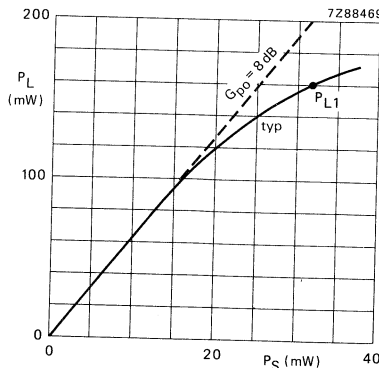

Fig. 5 $V_{CE} = 18\text{ V}$; $I_C = 30\text{ mA}$;
 $f = 4\text{ GHz}$; $T_{case} = 25\text{ }^{\circ}\text{C}$.

* Circuit consists of prematching circuit board in combination with input and output slug tuners.

LOW-NOISE MICROWAVE TRANSISTOR

N-P-N transistor for common-emitter class-A low-noise amplifiers up to 4GHz. Diffused emitter ballasting resistors, self-aligned process entirely ion implanted and gold sandwich metallization ensure an optimum temperature profile, excellent performance and reliability.

A miniature ceramic encapsulation is used for compatibility with stripline and microwave circuits.

QUICK REFERENCE DATA

R.F. performance up to $T_{\text{case}} = 25\text{ }^{\circ}\text{C}$ in an unneutralized common-emitter class-A circuit

mode of operation	f GHz	V_{CE} V	I_{C} mA	F_{min} dB	G_{a} dB
c.w.; linear amplifier	2	10	4	typ. 1,8	typ. 12

This data must be read in conjunction with GENERAL SAFETY RECOMMENDATIONS – MICROWAVE SEMICONDUCTORS

MECHANICAL DATA

Dimensions in mm

Fig. 1 SOT-100.

Emitter connected to metallized lid

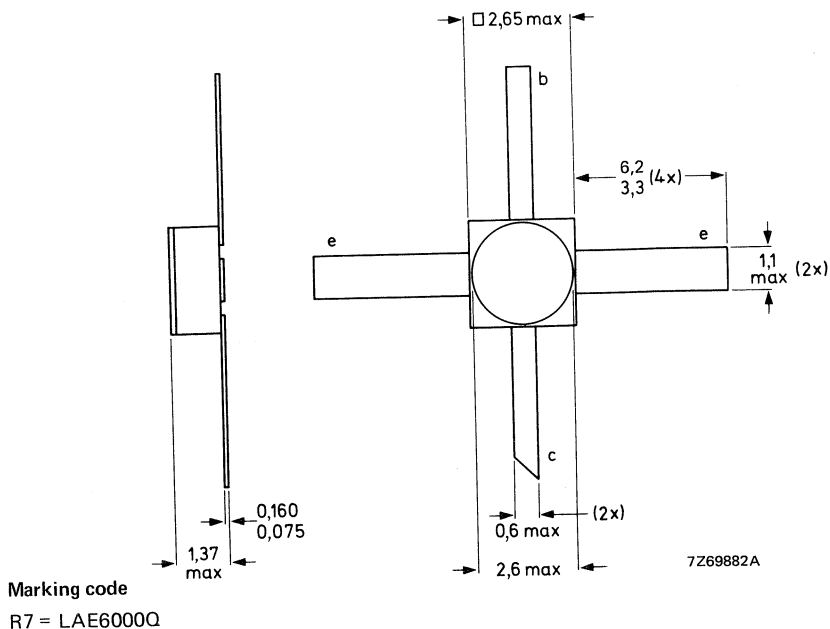

RATINGS

Limiting values in accordance with the Absolute Maximum System (IEC 134).

Collector-base voltage (open emitter)	V_{CBO}	max.	25 V
Collector-emitter voltage ($R_{BE} = 150 \Omega$) (open base)	V_{CER}	max.	20 V
	V_{CEO}	max.	12 V
Emitter-base voltage (open collector)	V_{EBO}	max.	2 V
Collector current (d.c.)	I_C	max.	15 mA
Total power dissipation up to $T_{case} = 150 \text{ }^\circ\text{C}$	P_{tot}	max.	150 mW
Storage temperature	T_{stg}		-65 to +200 $^\circ\text{C}$
Junction temperature	T_j	max.	200 $^\circ\text{C}$
Lead soldering temperature at 0,1 mm from the case; $t_{sld} \leq 10 \text{ s}$	T_{sld}	max.	235 $^\circ\text{C}$

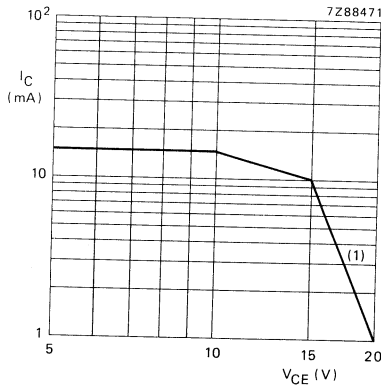

(1) Second breakdown limit (independent of temperature).

Fig. 2 D.C. SOAR at $T_{case} \leq 150 \text{ }^\circ\text{C}$; $R_{BE} \leq 150 \Omega$.

THERMAL RESISTANCE

From junction to case

$$R_{th \text{ j-c}} = 300 \text{ }^\circ\text{C/W}$$

CHARACTERISTICS

$T_{case} = 25\text{ }^{\circ}\text{C}$

Collector cut-off current

$I_E = 0; V_{CB} = 10\text{ V}$

$I_{CBO} < 100\text{ nA}$

Emitter cut-off current

$I_C = 0; V_{EB} = 1,5\text{ V}$

$I_{EBO} < 15\text{ nA}$

D.C. current gain

$I_C = 4\text{ mA}; V_{CE} = 10\text{ V}$

$h_{FE} \quad 20\text{ to }250$

Collector-base capacitance at $f = 1\text{ MHz}$

$I_E = I_C = 0; V_{CB} = 10\text{ V}$

$C_{cb} \quad \text{typ. } 0,15\text{ pF}$

Collector-emitter capacitance at $f = 1\text{ MHz}$

$I_E = I_C = 0; V_{CE} = 10\text{ V}$

$C_{ce} \quad \text{typ. } 0,50\text{ pF}$

Emitter-base capacitance at $f = 1\text{ MHz}$

$I_E = I_C = 0; V_{EB} = 1,0\text{ V}; V_{CB} = 10\text{ V}$

$C_{eb} \quad \text{typ. } 0,70\text{ pF}$

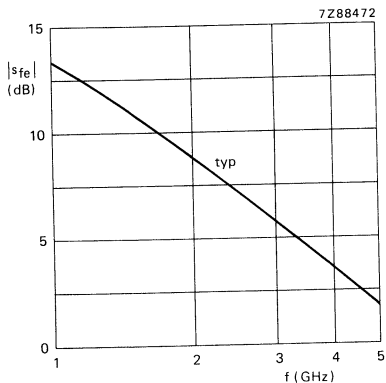

Fig. 3 $V_{CE} = 10\text{ V}; I_C = 4\text{ mA}; T_{case} = 25\text{ }^{\circ}\text{C}; Z_0 = 50\text{ }\Omega$.

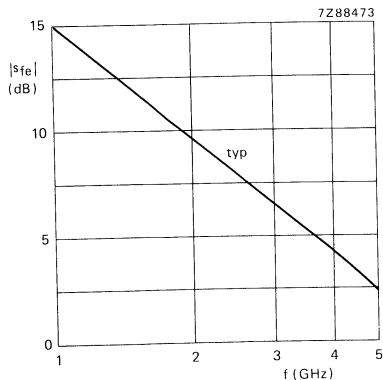

Fig. 4 $V_{CE} = 10\text{ V}; I_C = 8\text{ mA}; T_{case} = 25\text{ }^{\circ}\text{C}; Z_0 = 50\text{ }\Omega$.

s-parameters (common emitter)

Typical values; $V_{CE} = 10 \text{ V}$; $I_C = 4 \text{ mA}$; $T_{case} = 25 \text{ }^\circ\text{C}$; $Z_o = 50 \text{ } \Omega$

f MHz	S_{ie}	S_{re}	S_{fe}	S_{oe}
500	0,65/ -78°	0,025(-32,1)/ 50°	6,53(16,4)/ 126°	0,83/ -16°
600	0,62/ -94°	0,028(-30,9)/ 47°	6,16(15,8)/ 121°	0,83/ -18°
700	0,59/-100°	0,032(-30,0)/ 43°	5,82(15,3)/ 113°	0,83/ -25°
800	0,57/-111°	0,034(-29,4)/ 39°	5,40(14,6)/ 107°	0,80/ -27°
900	0,56/-120°	0,036(-29,0)/ 36°	5,00(14,0)/ 101°	0,79/ -29°
1000	0,55/-129°	0,039(-28,6)/ 34°	4,71(13,5)/ 96°	0,78/ -31°
1200	0,53/-143°	0,040(-27,9)/ 32°	4,19(12,4)/ 86°	0,76/ -34°
1400	0,52/-156°	0,042(-27,5)/ 29°	3,70(11,4)/ 77°	0,74/ -40°
1600	0,51/-168°	0,045(-26,8)/ 28°	3,35(10,5)/ 70°	0,74/ -41°
1800	0,51/-176°	0,047(-26,5)/ 28°	3,04(9,7)/ 62°	0,73/ -45°
2000	0,51/ 175°	0,049(-26,1)/ 27°	2,78(8,9)/ 56°	0,73/ -49°
2500	0,51/ 156°	0,055(-25,2)/ 26°	2,30(7,3)/ 41°	0,71/ -57°
3000	0,52/ 139°	0,062(-24,2)/ 24°	1,95(5,8)/ 27°	0,70/ -68°
3500	0,55/ 126°	0,069(-23,3)/ 22°	1,70(4,6)/ 12°	0,70/ -80°
4000	0,57/ 114°	0,076(-22,0)/ 20°	1,54(3,7)/ -2°	0,70/ -93°
4500	0,60/ 104°	0,084(-21,5)/ 14°	1,38(2,8)/ -15°	0,70/ -108°
5000	0,61/ 95°	0,094(-20,5)/ 8°	1,22(1,8)/ -29°	0,70/ -124°
5500	0,63/ 87°	0,105(-19,6)/ 3°	1,11(0,8)/ -42°	0,71/ -141°
6000	0,63/ 80°	0,114(-18,9)/ -3°	1,00(0)/ -55°	0,74/ -157°

Typical values; $V_{CE} = 10 \text{ V}$; $I_C = 8 \text{ mA}$; $T_{case} = 25 \text{ }^\circ\text{C}$; $Z_o = 50 \text{ } \Omega$

f MHz	S_{ie}	S_{re}	S_{fe}	S_{oe}
500	0,52/-111°	0,019(-34,6)/ 47°	9,43(19,5)/ 117°	0,80/ -21°
600	0,51/-126°	0,020(-33,9)/ 45°	8,19(18,3)/ 109°	0,78/ -23°
700	0,50/-134°	0,022(-33,1)/ 43°	7,53(17,5)/ 102°	0,76/ -25°
800	0,50/-143°	0,024(-32,5)/ 42°	6,70(16,5)/ 97°	0,74/ -26°
900	0,50/-150°	0,025(-32,0)/ 42°	6,17(15,8)/ 92°	0,73/ -28°
1000	0,50/-157°	0,027(-31,4)/ 41°	5,68(15,1)/ 87°	0,73/ -29°
1200	0,50/-168°	0,030(-30,5)/ 41°	4,88(13,8)/ 79°	0,72/ -33°
1400	0,50/-176°	0,033(-29,7)/ 43°	4,22(12,5)/ 70°	0,70/ -38°
1600	0,50/ 173°	0,036(-28,8)/ 39°	3,76(11,5)/ 64°	0,70/ -39°
1800	0,50/ 167°	0,039(-28,1)/ 40°	3,40(10,6)/ 58°	0,70/ -43°
2000	0,50/ 160°	0,042(-27,5)/ 41°	3,08(9,8)/ 52°	0,70/ -47°
2500	0,52/ 144°	0,050(-26,0)/ 38°	2,54(8,1)/ 38°	0,69/ -56°
3000	0,54/ 131°	0,060(-24,5)/ 35°	2,13(6,6)/ 24°	0,68/ -66°
3500	0,56/ 119°	0,068(-23,3)/ 32°	1,86(5,4)/ 10°	0,67/ -78°
4000	0,59/ 108°	0,078(-22,2)/ 28°	1,66(4,4)/ -4°	0,67/ -91°
4500	0,61/ 99°	0,086(-21,3)/ 22°	1,48(3,4)/ -17°	0,67/ -106°
5000	0,63/ 91°	0,098(-20,2)/ 14°	1,31(2,4)/ -30°	0,67/ -122°
5500	0,64/ 84°	0,110(-19,2)/ 8°	1,19(1,5)/ -43°	0,69/ -139°
6000	0,64/ 77°	0,119(-18,5)/ 2°	1,07(0,6)/ -56°	0,73/ -155°

The figures given between brackets are values in dB.

MICROWAVE LINEAR POWER TRANSISTORS

N-P-N bipolar transistors for use in a common-emitter class-A linear power amplifier up to 1 GHz. Diffused emitter ballasting resistors, interdigitated structure, multicell geometry and gold sandwich metallization ensure an optimum temperature profile, excellent performance and reliability.

The LBE1004R and LBE1010R have a metal ceramic studless envelope.
The LCE1004R and LCE1010R have a metal ceramic capstan envelope.

QUICK REFERENCE DATA

R.F. performance up to $T_{mb} = 25\text{ }^{\circ}\text{C}$ in an unneutralized common-emitter class-A circuit

type number	mode of operation	f GHz	V_{CE} V	I_C mA	P_{L1} mW	G_{po} dB	\bar{z}_i Ω	\bar{z}_L Ω
LBE/LCE1004R	c.w.; linear amplifier	1	15	100	typ. 500	typ. 10	$5 + j10$	$25 + j25$
LBE/LCE1010R	c.w.; linear amplifier	1	15	200	typ. 1000	typ. 9	$4 + j9$	$20 + j15$

MECHANICAL DATA

see page 2

This data must be read in conjunction with GENERAL SAFETY RECOMMENDATIONS--MICROWAVE SEMICONDUCTORS.

POTENTIAL HAZARD--BERYLLIUM OXIDE

This device contains beryllium oxide, the dust of which is toxic. The device is entirely safe, provided that the beryllium oxide disc is not damaged. Care should be taken to ensure that all those who may handle, use or dispose of this device are aware of its nature and of the necessary safety precautions. In particular, it should never be thrown out with general industrial or domestic waste.

MECHANICAL DATA

Fig. 1a LBE1004R and LBE1010R.

Dimensions in mm

Marking code

RTC109 = LBE1004R

RTC143 = LBE1010R

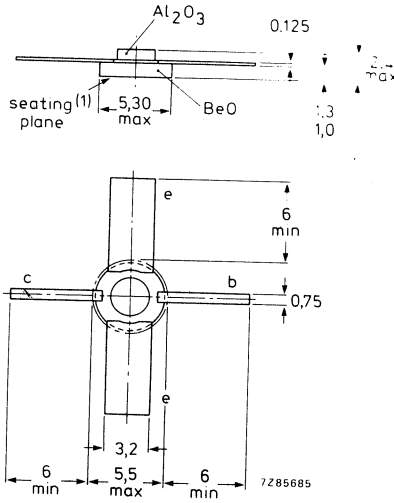

(1) Metallized.



MECHANICAL DATA (continued)

Fig. 1b LCE1004R and LCE1010R.

Marking code

RTC108 = LCE1004R

RTC142 = LCE1010R

Torque on nut: min. 0,75 Nm
0,85 Nm

Diameter of clearance hole
in heatsink: max. 4,2 mm.

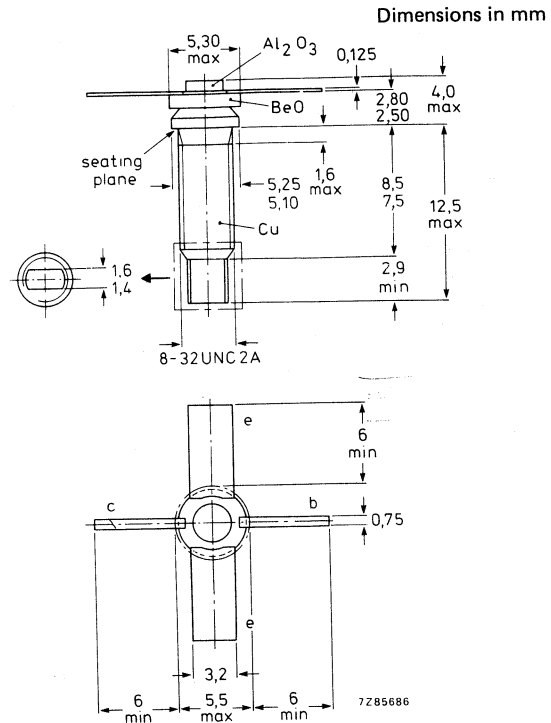

RATINGS

Limiting values in accordance with the Absolute Maximum System (IEC 134)

		LBE/LCE 1004R	LBE/LCE 1010R	
Collector-base voltage (open emitter)	V_{CBO}	max. 30	30	V
Collector-emitter voltage $R_{BE} = 250 \Omega$ $R_{BE} = 500 \Omega$ (open base)	V_{CER}	max. —	30	V
	V_{CER}	max. 30	—	V
	V_{CEO}	max. 14	14	V
Emitter-base voltage (open collector)	V_{EBO}	max. 3	3	V
Collector current d.c. (peak value); $f > 1 \text{ MHz}$	I_C	max. 400	800	mA
	I_{CM}	max. 800	1600	mA
Total power dissipation up to $T_{mb} = 75 \text{ }^\circ\text{C}$	P_{tot}	max. 3	6	W
Storage temperature	T_{stg}	-65 to +150		$^\circ\text{C}$
Operating junction temperature	T_j	max.	200	$^\circ\text{C}$
Lead soldering temperature at 0,3 mm from the case; $t_{slid} = 10 \text{ s}$	T_{slid}	max.	235	$^\circ\text{C}$

LBE/LCE1004R

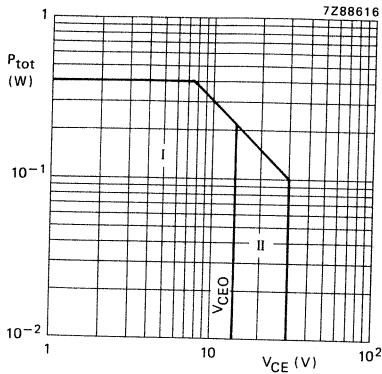

Fig. 2 D.C. SOAR at $T_{mb} \leq 75 \text{ }^\circ\text{C}$.
I Region of permissible d.c. operation.
II Permissible extension provided $R_{BE} \leq 500 \text{ } \Omega$.

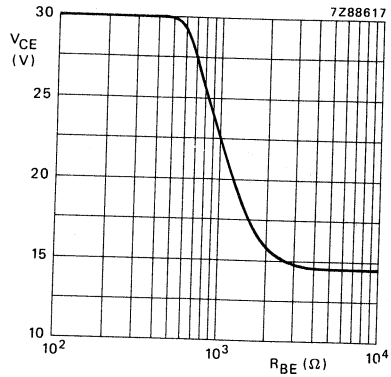
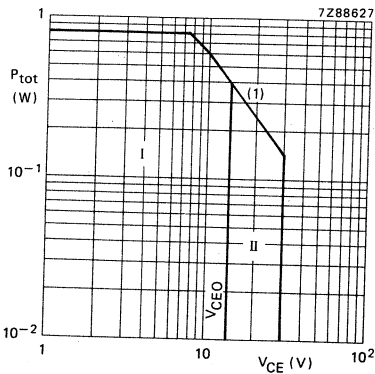

Fig. 3 Maximum permissible collector-emitter voltage as a function of R_{BE} .

LBE/LCE1010R



(1) Second breakdown limit (independent of temperature).
Fig. 4 D.C. SOAR at $T_{mb} \leq 75 \text{ }^\circ\text{C}$.
I Region of permissible d.c. operation.
II Permissible extension provided $R_{BE} \leq 250 \text{ } \Omega$.

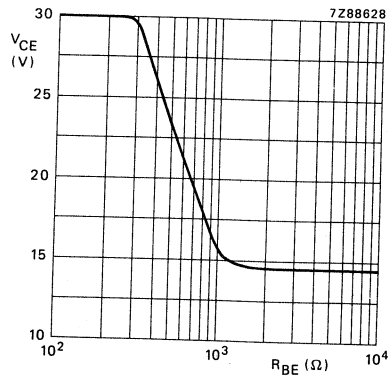

Fig. 5 Maximum permissible collector-emitter voltage as a function of R_{BE} .

THERMAL RESISTANCE

From junction to mounting base
From mounting base to heatsink

		LBE/LCE 1004R	LBE/LCE 1010R	
$R_{th\ j-mb}$	=	30	17	°C/W
$R_{th\ mb-h}$	=	1,5	1,5	°C/W

CHARACTERISTICS

$T_{mb} = 25\text{ °C}$

		LBE/LCE 1004R	LBE/LCE 1010R	
Collector-base breakdown voltage open emitter; $I_C = 1,0\text{ mA}$	$V_{(BR)CBO} >$	—	30	V
open emitter; $I_C = 0,5\text{ mA}$	$V_{(BR)CBO} >$	30	—	V
Collector-emitter breakdown voltage $R_{BE} = 250\ \Omega$; $I_C = 10\text{ mA}$	$V_{(BR)CER} >$	—	30	V
$R_{BE} = 500\ \Omega$; $I_C = 5\text{ mA}$	$V_{(BR)CER} >$	30	—	V
open base; $-I_E = 10\text{ mA}$	$V_{(BR)CEO} >$	—	14	V
open base; $-I_E = 5\text{ mA}$	$V_{(BR)CEO} >$	14	—	V
Emitter-base breakdown voltage open collector; $I_E = 2\text{ mA}$	$V_{(BR)EBO} >$	—	3	V
open collector; $I_E = 1\text{ mA}$	$V_{(BR)EBO} >$	3	—	V
Collector cut-off current $I_E = 0$; $V_{CB} = 20\text{ V}$	$I_{CBO} <$	0,2	0,4	mA
Emitter cut-off current $I_C = 0$; $V_{EB} = 2\text{ V}$	$I_{EBO} <$	0,2	0,4	mA
D.C. current gain $I_C = 75\text{ mA}$; $V_{CE} = 5\text{ V}$	$h_{FE} >$	20	20	
Collector-base capacitance at $f = 1\text{ MHz}$ $I_E = I_C = 0$; $V_{CB} = 14\text{ V}$	C_{cb} typ.	1,7	2,0	pF
Collector-emitter capacitance at $f = 1\text{ MHz}$ $I_B = I_b = 0$; $V_{CE} = 14\text{ V}$	C_{ce} typ.	1,2	2,0	pF
Emitter-base capacitance at $f = 1\text{ MHz}$ $I_E = I_e = 0$; $V_{EB} = 1\text{ V}$	C_{eb} typ.	4,2	8,2	pF
Forward power gain $I_C = 100\text{ mA}$; $V_{CE} = 15\text{ V}$; $f = 1\text{ GHz}$	$ s_{fe} ^2$ typ.	6,5	—	dB
$I_C = 200\text{ mA}$; $V_{CE} = 15\text{ V}$; $f = 1\text{ GHz}$	$ s_{fe} ^2$ typ.	—	4,0	dB
Maximum available gain $I_C = 100\text{ mA}$; $V_{CE} = 15\text{ V}$; $f = 1\text{ GHz}$	GAM typ.	10,5	—	dB
$I_C = 200\text{ mA}$; $V_{CE} = 15\text{ V}$; $f = 1\text{ GHz}$	GAM typ.	—	10,0	dB



s-parameters (common emitter)

LBE/LCE1004R: Typical values; $V_{CE} = 15 \text{ V}$; $I_C = 100 \text{ mA}$; $T_{mb} = 25 \text{ }^\circ\text{C}$; $Z_O = 50 \text{ } \Omega$

f GHz	s_{ie}	s_{re}	s_{fe}	s_{oe}
0,2	0,69/−162°	0,063(−24)/30°	7,95(18)/100°	0,38/−129°
0,5	0,68/ 177°	0,079(−22)/38°	3,99(12)/ 80°	0,36/−159°
1	0,68/ 154°	0,10 (−20)/45°	2,24(6,5)/ 60°	0,37/−175°
1,5	0,68/ 132°	0,14 (−17)/46°	1,41(3)/ 40°	0,38/ 176°
2	0,67/ 120°	0,16 (−16)/46°	1,13(1)/ 20°	0,42/ 168°

The figures given between brackets are values in dB.

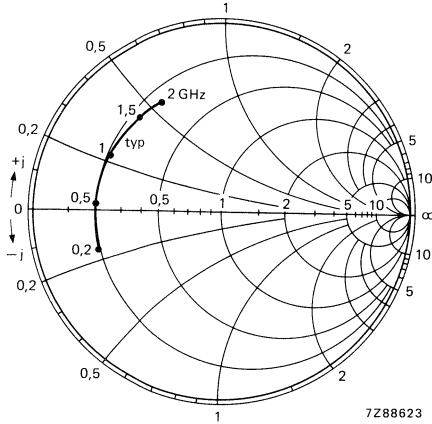

Fig. 6 Input reflection coefficient s_{ie} .

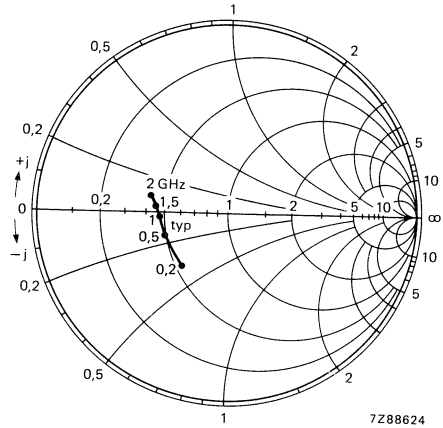

Fig. 7 Output reflection coefficient s_{oe} .

Conditions for Figs 6 and 7:

LBE/LCE1004R: Typical values; $V_{CE} = 15 \text{ V}$; $I_C = 100 \text{ mA}$; $T_{mb} = 25 \text{ }^\circ\text{C}$; $Z_O = 50 \text{ } \Omega$.

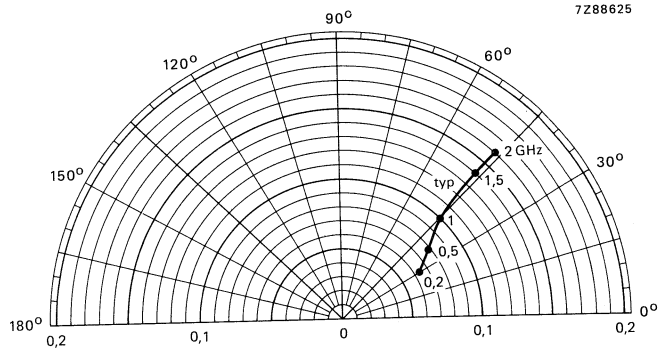

Fig. 8 Reverse transmission coefficient s_{re} .

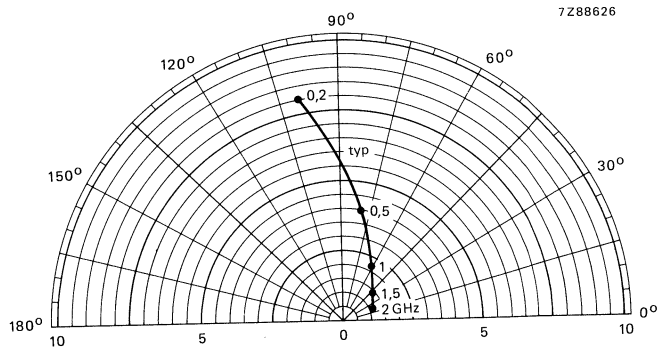

Fig. 9 Forward transmission coefficient s_{fe} .

Conditions for Figs 8 and 9:

LBE/LCE1004R: Typical values; $V_{CE} = 15 \text{ V}$; $I_C = 100 \text{ mA}$; $T_{mb} = 25 \text{ }^\circ\text{C}$; $Z_o = 50 \text{ } \Omega$.

LBE/LCE1010R: Typical values; $V_{CE} = 15 \text{ V}$; $I_C = 200 \text{ mA}$; $T_{mb} = 25 \text{ }^\circ\text{C}$; $Z_0 = 50 \text{ } \Omega$

f GHz	s_{ie}	s_{re}	s_{fe}	s_{oe}
0,25	0,85/180°	0,04(-28)/35°	5,0 (14)/95°	0,51/-157°
0,50	0,85/172°	0,05(-26)/45°	2,8 (9)/75°	0,53/-175°
0,75	0,85/164°	0,07(-23)/55°	2,0 (6)/65°	0,54/ 178°
1	0,85/158°	0,09(-21)/55°	1,6 (4)/60°	0,58/ 173°
1,25	0,85/150°	0,10(-20)/55°	1,26(2)/58°	0,59/ 167°
1,50	0,85/144°	0,11(-19)/52°	1,13(1)/53°	0,61/ 163°
1,75	0,85/139°	0,12(-18)/50°	0,90(-1)/50°	0,62/ 159°
2	0,85/133°	0,15(-16)/50°	0,80(-2)/45°	0,62/ 154°

The figures given between brackets are values in dB.

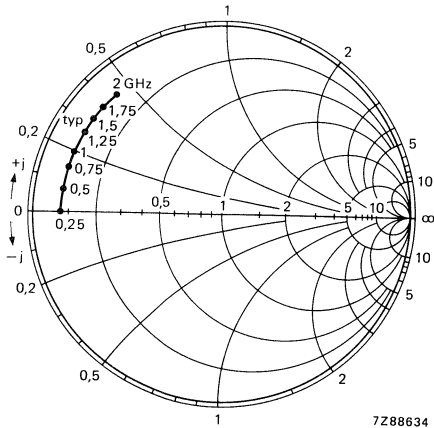

Fig. 10 Input reflection coefficient s_{ie} .

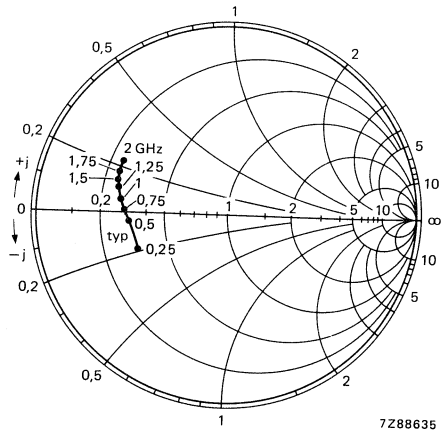

Fig. 11 Output reflection coefficient s_{oe} .

Conditions for Figs 10 and 11:

LBE/LCE1010R: Typical values; $V_{CE} = 15 \text{ V}$; $I_C = 200 \text{ mA}$; $T_{mb} = 25 \text{ }^\circ\text{C}$; $Z_0 = 50 \text{ } \Omega$.

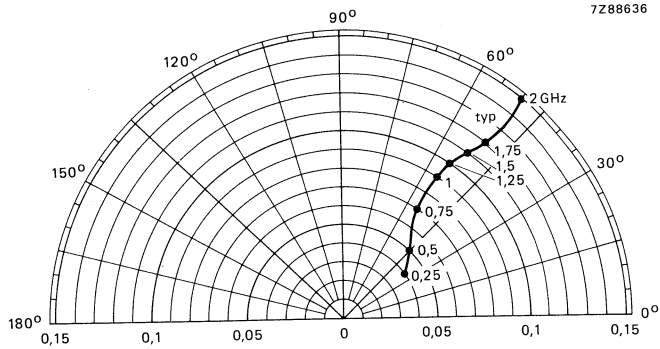

Fig. 12 Reverse transmission coefficient s_{re} .

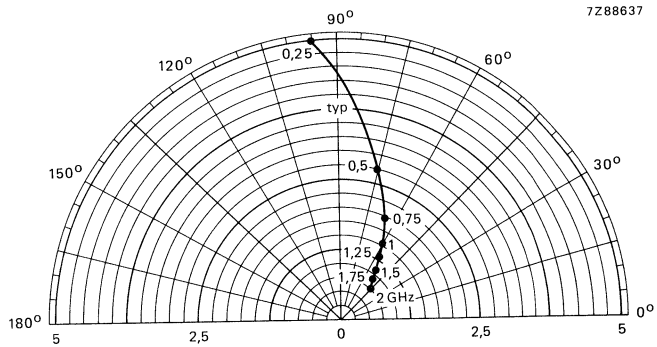

Fig. 13 Forward transmission coefficient s_{fe} .

Conditions for Figs 12 and 13:

LBE/LCE1010R: Typical values: $V_{CE} = 15 \text{ V}$; $I_C = 200 \text{ mA}$; $T_{mb} = 25 \text{ }^\circ\text{C}$; $Z_o = 50 \text{ } \Omega$.

APPLICATION INFORMATION

R.F. performance LBE/LCE1004R up to $T_{mb} = 25\text{ }^{\circ}\text{C}$ in an unneutralized common-emitter class-A circuit

f GHz	V_{CE} (1) V	I_C (1) mA	P_{L1} (2) mW(dBm)	G_{po} (3) dB	P_{Lsat} (4) mW (dBm)
1	15	100	$\geq 400(26)$ typ. 500(27)	≥ 8 typ. 10	— typ. 631(28)

Notes

1. V_{CE} and I_C regulated.
2. Load power for 1 dB compressed power gain.
3. Low-level power gain associated with P_{L1} .
4. Saturated output power of the transistor.

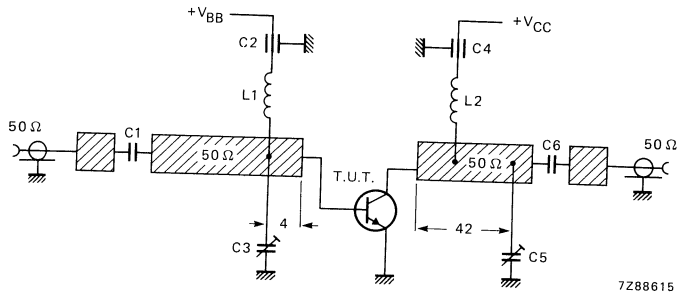

Fig. 14 Class-A test circuit at $f = 1\text{ GHz}$. (Dimensions in mm.)

List of components:

C1 = C6 = 1 nF multilayer ceramic chip capacitor

C2 = C4 = 500 pF ceramic feed-through capacitor

C3 = C5 = 0 to 10 pF film dielectric trimmer

L1 = L2 = 5 turns enamelled Cu wire (0,5 mm); internal diameter 2,5 mm

Striplines on a double Cu-clad printed-circuit board with PTFE fibre-glass dielectric ($\epsilon_r = 2,54$); thickness 0,8 mm.

R.F. performance LBE/LCE1010R up to $T_{mb} = 25\text{ }^{\circ}\text{C}$ in an unneutralized common-emitter class-A circuit

f GHz	V_{CE} (1) V	I_C (1) mA	P_{L1} (2) mW(dBm)	G_{po} (3) dB	P_{Lsat} (4) mW(dBm)
1	15	200	$\geq 800(29)$ typ. 1000(30)	≥ 7 typ. 9	— typ. 1600(32)

Notes

1. V_{CE} and I_C regulated.
2. Load power for 1 dB compressed power gain.
3. Low-level power gain associated with P_{L1} .
4. Saturated output power of the transistor.

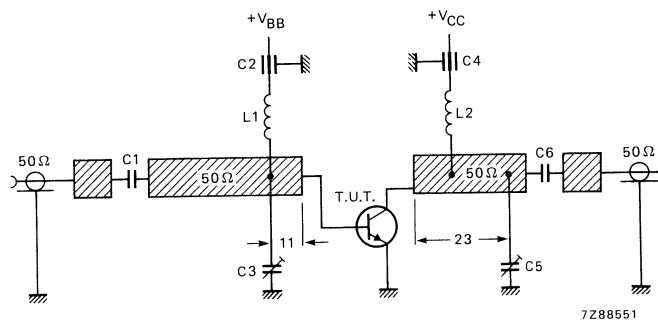

Fig. 15 Class-A test circuit at $f = 1\text{ GHz}$. (Dimensions in mm.)

List of components:

C1 = C6 = 1 nF multilayer ceramic chip capacitor

C2 = C4 = 500 pF ceramic feed-through capacitor

C3 = C5 = 0 to 10 pF film dielectric trimmer

L1 = L2 = 5 turns enamelled Cu wire (0,5 mm); internal diameter 2,5 mm

Striplines on a double Cu-clad printed-circuit board with PTFE fibre-glass dielectric ($\epsilon_r = 2,54$); thickness 0,8 mm.

LBE/LCE1004R

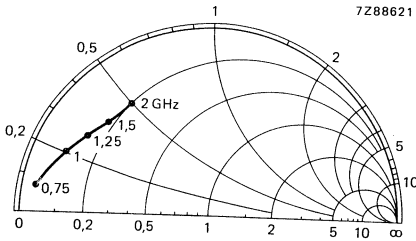

Fig. 16 Input impedance as a function of frequency for P_{L1} .

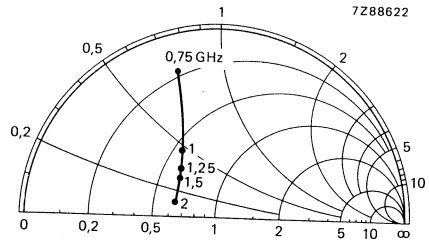

Fig. 17 Optimum load impedance as a function of frequency for P_{L1} .

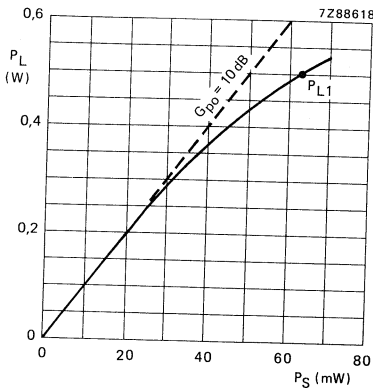

Fig. 18 Load power as a function of source power at $f = 1$ GHz.

Conditions for Figs 16 to 20:
 V_{CE} and I_C regulated.
 $V_{CE} = 15$ V; $I_C = 100$ mA;
 $T_{mb} = 25$ °C; typical values.

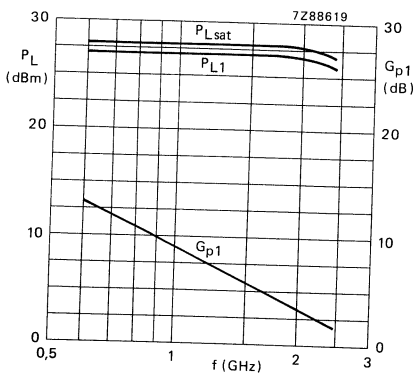

Fig. 19 P_{Lsat} , P_{L1} and G_{p1} associated with P_{L1} as a function of frequency.

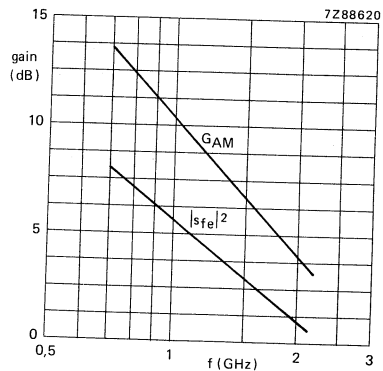

Fig. 20 G_{AM} and $|S_{fe}|^2$ as a function of frequency.

LBE/LCE1010R

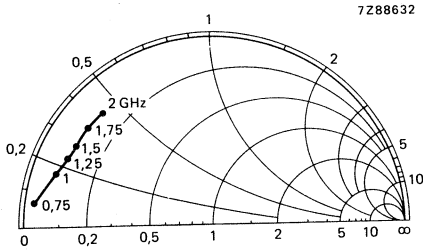

Fig. 21 Input impedance as a function of frequency for P_{L1} .

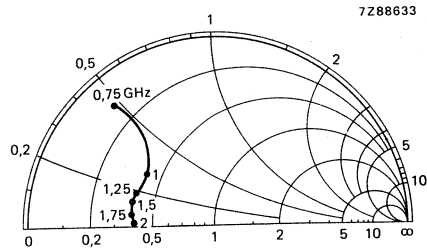

Fig. 22 Optimum load impedance as a function of frequency for P_{L1} .

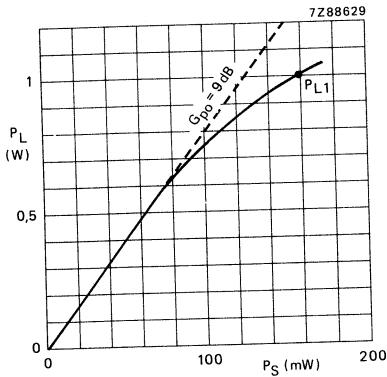

Fig. 23 Load power as a function of source power at $f = 1$ GHz.

Conditions for Figs 21 to 25:
 V_{CE} and I_C regulated.
 $V_{CE} = 15$ V; $I_C = 200$ mA;
 $T_{mb} = 25$ °C; typical values.

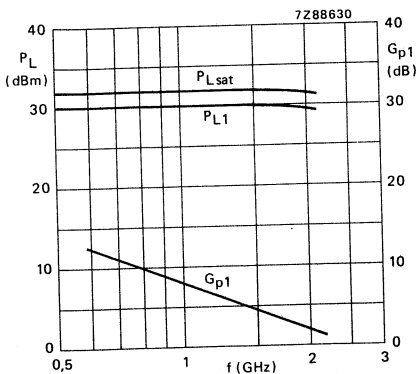

Fig. 24 P_{Lsat} , P_{L1} and G_{p1} associated with P_{L1} as a function of frequency.

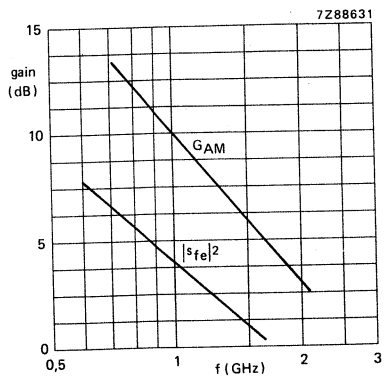

Fig. 25 G_{AM} and $|S_{fe}|^2$ as a function of frequency.

MICROWAVE LINEAR POWER TRANSISTORS

N-P-N transistors for use in a common-emitter class-A linear power amplifier up to 2 GHz.
Diffused emitter ballasting resistors, self-aligned process entirely ion implanted and gold metallization ensure an optimum temperature profile, excellent performance and reliability.

The LBE2003S and LBE2009S have a metal ceramic studless envelope.
The LCE2003S and LCE2009S have a metal ceramic capstan envelope.

QUICK REFERENCE DATA

R.F. performance up to $T_{mb} = 25\text{ }^{\circ}\text{C}$ in an unneutralized common-emitter class-A circuit

type number	mode of operation	f GHz	V_{CE} V	I_C mA	P_{L1} mW	G_{po} dB	\bar{z}_i Ω	\bar{z}_L Ω
LBE/LCE2003S	c.w.; linear amplifier	2	18	30	typ. 250	typ. 11	$6,2 + j30$	$17,5 + j7$
LBE/LCE2009S	c.w.; linear amplifier	2	18	110	typ. 900	typ. 9,8	$7,5 + j15$	$17,5 + j39$

MECHANICAL DATA

see page 2

This data must be read in conjunction with GENERAL SAFETY RECOMMENDATIONS—MICROWAVE SEMICONDUCTORS.

POTENTIAL HAZARD—BERYLLIUM OXIDE

This device contains beryllium oxide, the dust of which is toxic. The device is entirely safe, provided that the beryllium oxide disc is not damaged. Care should be taken to ensure that all those who may handle, use or dispose of this device are aware of its nature and of the necessary safety precautions. In particular, it should never be thrown out with general industrial or domestic waste.

MECHANICAL DATA

Dimensions in mm

Fig. 1a LBE2003S and LBE2009S.

Marking code

RTC407 = LBE2003S

RTC409 = LBE2009S

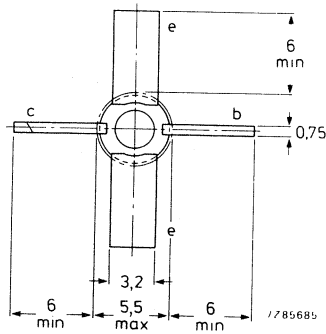
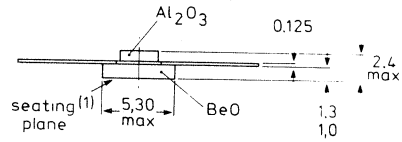

MECHANICAL DATA (continued)

Dimensions in mm

Fig. 1b LCE2003S and LCE2009S.

Marking code

RTC406 = LCE2003S

RTC408 = LCE2009S

Torque on nut: min. 0,75 Nm
0,85 Nm

Diameter of clearance hole in
heatsink: max. 4,2 mm.

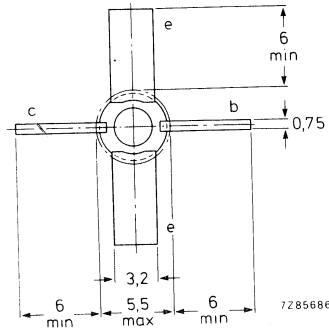
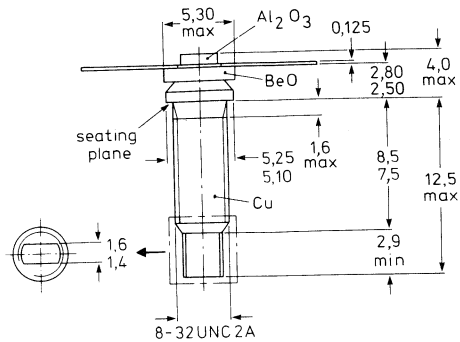

RATINGS

Limiting values in accordance with the Absolute Maximum System (IEC 134)

		LBE/LCE 2003S	LBE/LCE 2009S	
Collector-base voltage (open emitter)	V_{CBO}	max. 40	40	V
Collector-emitter voltage $R_{BE} = 100 \Omega$	V_{CER}	max. —	35	V
$R_{BE} = 220 \Omega$ (open base)	V_{CER}	max. 35	—	V
Emitter-base voltage (open collector)	V_{CEO}	max. 16	16	V
Collector current (d.c.)	V_{EBO}	max. 3	3	V
Total power dissipation up to $T_{mb} = 75 \text{ }^\circ\text{C}$	I_C	max. 90	250	mA
Storage temperature	P_{tot}	max. 1,4	3,5	W
Operating junction temperature	T_{stg}	-65 to +150		$^\circ\text{C}$
Lead soldering temperature at 0,3 mm from the case; $t_{sld} = 10 \text{ s}$	T_j	max.	200	$^\circ\text{C}$
	T_{sld}	max.	235	$^\circ\text{C}$

LBE/LCE2003S

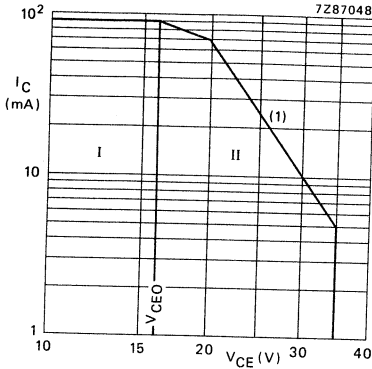

(1) Second breakdown limit
(independent of temperature).

Fig. 2 D.C. SOAR at $T_{mb} \leq 75 \text{ }^\circ\text{C}$.

I Region of permissible d.c. operation.

II Permissible extension provided $R_{BE} \leq 220 \text{ } \Omega$.

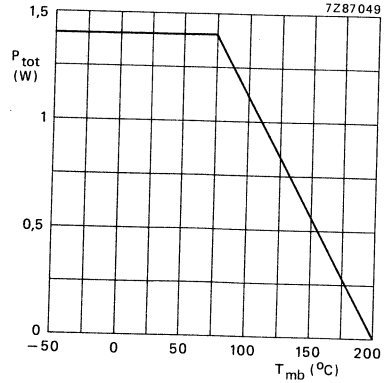
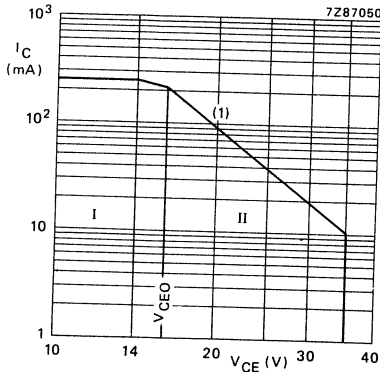

Fig. 3 Power derating curve vs.
mounting base temperature.

LBE/LCE2009S



(1) Second breakdown limit
(independent of temperature).

Fig. 4 D.C. SOAR at $T_{mb} \leq 75 \text{ }^\circ\text{C}$.

I Region of permissible d.c. operation.

II Permissible extension provided $R_{BE} \leq 100 \text{ } \Omega$.

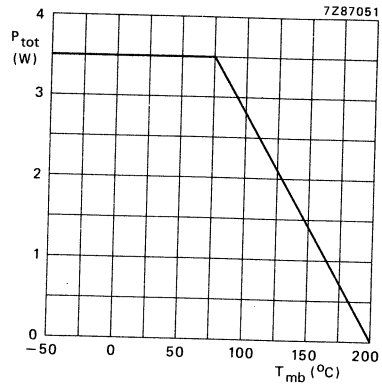

Fig. 5 Power derating curve vs.
mounting base temperature.

THERMAL RESISTANCE

From junction to mounting base
From mounting base to heatsink

	LBE/LCE 2003S	LBE/LCE 2009S	
$R_{th\ j-mb}$	65	36	$^{\circ}C/W$
$R_{th\ mb-h}$	1,5	1,5	$^{\circ}C/W$

CHARACTERISTICS

$T_{mb} = 25^{\circ}C$

Collector cut-off current

$I_E = 0; V_{CB} = 20\ V$

$I_E = 0; V_{CB} = 40\ V$

$V_{CB} = 35\ V; R_{BE} = 220\ \Omega$

$V_{CB} = 35\ V; R_{BE} = 100\ \Omega$

Emitter cut-off current

$I_C = 0; V_{EB} = 1,5\ V$

$I_C = 0; V_{EB} = 3,0\ V$

D.C. current gain

$I_C = 30\ mA; V_{CE} = 5\ V$

$I_C = 110\ mA; V_{CE} = 5\ V$

Collector-base capacitance at $f = 1\ MHz$

$I_E = I_C = 0; V_{CB} = 18\ V; V_{EB} = 1,5\ V$

Collector-emitter capacitance at $f = 1\ MHz$

$I_E = I_C = 0; V_{CE} = 18\ V; V_{EB} = 1,5\ V$

Emitter-base capacitance at $f = 1\ MHz$

$I_E = I_C = 0; V_{EB} = 1\ V; V_{CB} = 10\ V$

	LBE/LCE 2003S	LBE/LCE 2009S	
I_{CBO}	< 0,1	0,1	μA
I_{CBO}	< 150	250	μA
I_{CER}	< 500	—	μA
I_{CER}	< —	1000	μA
I_{EBO}	< 0,05	0,2	μA
I_{EBO}	< 25	50	μA
h_{FE}	> 15	—	
h_{FE}	< 150	—	
h_{FE}	> —	15	
h_{FE}	< —	150	
C_{cb}	typ. 0,3	0,6	pF
C_{ce}	typ. 0,45	0,6	pF
C_{eb}	typ. 1,7	3,3	pF



s-parameters (common emitter)

LBE/LCE2003S: Typical values; $V_{CE} = 18 \text{ V}^*$; $I_C = 30 \text{ mA}^*$; $T_{mb} = 25 \text{ }^\circ\text{C}$; $Z_o = 50 \text{ } \Omega$

f GHz	s_{ie}	s_{re}	s_{fe}	s_{oe}
0,5	0,56/−143°	0,037(−28,6)/ 41°	9,50(19,6)/ 101°	0,56/ −34°
0,6	0,55/−154°	0,040(−28,0)/ 39°	8,28(18,4)/ 93°	0,51/ −35°
0,7	0,55/−164°	0,040(−27,9)/ 40°	7,13(17,1)/ 88°	0,50/ −36°
0,8	0,55/−171°	0,041(−27,7)/ 40°	6,35(16,1)/ 82°	0,49/ −37°
0,9	0,55/−178°	0,043(−27,4)/ 41°	5,69(15,1)/ 77°	0,47/ −38°
1,0	0,55/+ 176°	0,045(−26,9)/ 40°	5,14(14,2)/ 72°	0,46/ −39°
1,1	0,55/+ 170°	0,048(−26,4)/ 40°	4,72(13,5)/ 68°	0,46/ −39°
1,2	0,55/+ 165°	0,051(−25,9)/ 41°	4,37(12,8)/ 64°	0,45/ −41°
1,3	0,56/+ 159°	0,056(−25,1)/ 41°	4,05(12,2)/ 60°	0,44/ −44°
1,4	0,55/+ 158°	0,060(−24,5)/ 41°	3,76(11,5)/ 57°	0,45/ −46°
1,5	0,55/+ 149°	0,062(−24,2)/ 40°	3,52(10,9)/ 53°	0,43/ −48°
1,6	0,55/+ 146°	0,065(−23,8)/ 42°	3,33(10,5)/ 50°	0,43/ −50°
1,7	0,56/+ 142°	0,068(−23,3)/ 42°	3,15(10,0)/ 46°	0,43/ −53°
1,8	0,57/+ 137°	0,070(−23,1)/ 41°	2,96(9,4)/ 42°	0,43/ −54°
1,9	0,57/+ 132°	0,072(−22,9)/ 40°	2,80(8,9)/ 39°	0,43/ −56°
2,0	0,58/+ 128°	0,074(−22,7)/ 40°	2,66(8,5)/ 36°	0,42/ −57°
2,2	0,60/+ 121°	0,081(−21,8)/ 39°	2,43(7,7)/ 28°	0,41/ −61°
2,4	0,62/+ 114°	0,091(−20,8)/ 37°	2,24(7,0)/ 23°	0,40/ −67°
2,6	0,64/+ 108°	0,099(−20,1)/ 36°	2,08(6,4)/ 16°	0,39/ −75°
2,8	0,66/+ 102°	0,105(−19,6)/ 33°	1,90(5,6)/ 10°	0,38/ −82°
3,0	0,68/ +96°	0,108(−19,4)/ 31°	1,79(5,1)/ 4°	0,39/ −87°
3,2	0,71/ +92°	0,124(−18,7)/ 29°	1,63(4,3)/ −2°	0,37/ −94°
3,4	0,73/ +89°	0,125(−18,0)/ 27°	1,58(4,0)/ −7°	0,40/ −101°
3,6	0,75/ +86°	0,137(−17,3)/ 25°	1,46(3,3)/ −13°	0,39/ −112°
3,8	0,76/ +82°	0,142(−17,0)/ 23°	1,40(2,9)/ −18°	0,38/ −120°
4,0	0,77/ +79°	0,149(−16,6)/ 20°	1,31(2,3)/ −24°	0,38/ −128°
4,2	0,78/ +75°	0,155(−16,2)/ 17°	1,25(1,9)/ −28°	0,38/ −133°
4,4	0,80/ +73°	0,167(−15,5)/ 15°	1,20(1,6)/ −34°	0,39/ −142°
4,6	0,81/ +69°	0,177(−15,0)/ 12°	1,14(1,1)/ −38°	0,39/ −151°
4,8	0,81/ +68°	0,187(−14,6)/ 10°	1,10(0,8)/ −43°	0,42/ −159°
5,0	0,81/ +65°	0,194(−14,3)/ 6°	1,04(0,4)/ −47°	0,44/ −165°
5,2	0,80/ +60°	0,203(−13,8)/ 4°	1,03(0,3)/ −53°	0,47/ −169°
5,4	0,81/ +56°	0,219(−13,2)/ −1°	0,98(−0,2)/ −57°	0,48/ −175°
5,6	0,81/ +51°	0,229(−12,8)/ −3°	0,97(−0,3)/ −62°	0,49/ +178°
5,8	0,81/ +48°	0,243(−12,3)/ −8°	0,92(−0,7)/ −68°	0,51/ +171°
6,0	0,80/ +44°	0,245(−12,2)/ −12°	0,90(−0,9)/ −72°	0,55/ +165°

The figures given between brackets are values in dB.

* V_{CE} and I_C regulated.

s-parameters (common emitter)

LBE/LCE2009S: Typical values; $V_{CE} = 18 \text{ V}^*$; $I_C = 110 \text{ mA}^*$; $T_{mb} = 25 \text{ }^\circ\text{C}$; $Z_o = 50 \Omega$

f GHz	S_{ie}	S_{re}	S_{fe}	S_{oe}
0,5	0,70/177°	0,029(-30,7)/50°	7,55(17,6)/ 83°	0,25/ -48°
0,6	0,70/171°	0,033(-29,6)/51°	6,43(16,2)/ 77°	0,22/ -50°
0,7	0,70/168°	0,036(-29,0)/53°	5,46(14,6)/ 73°	0,23/ -52°
0,8	0,70/163°	0,039(-28,4)/54°	4,80(13,6)/ 68°	0,22/ -54°
0,9	0,71/159°	0,041(-27,8)/54°	4,27(12,6)/ 64°	0,22/ -56°
1,0	0,71/155°	0,045(-27,0)/55°	3,84(11,7)/ 60°	0,21/ -59°
1,1	0,71/151°	0,049(-26,2)/54°	3,53(11,0)/ 56°	0,21/ -62°
1,2	0,71/148°	0,054(-25,4)/54°	3,27(10,3)/ 52°	0,21/ -65°
1,3	0,71/144°	0,060(-24,5)/53°	3,01(9,6)/ 48°	0,20/ -74°
1,4	0,72/143°	0,066(-23,6)/54°	2,80(9,0)/ 45°	0,20/ -79°
1,5	0,72/136°	0,070(-23,1)/52°	2,61(8,3)/ 41°	0,21/ -80°
1,6	0,72/133°	0,075(-22,5)/53°	2,47(7,9)/ 38°	0,21/ -83°
1,7	0,72/130°	0,080(-21,9)/51°	2,33(7,3)/ 34°	0,22/ -87°
1,8	0,73/127°	0,084(-21,5)/49°	2,18(6,8)/ 30°	0,22/ -90°
1,9	0,73/123°	0,087(-21,2)/48°	2,05(6,3)/ 26°	0,22/ -94°
2,0	0,74/120°	0,090(-20,9)/46°	1,97(5,9)/ 23°	0,22/ -97°
2,2	0,75/114°	0,100(-20,0)/43°	1,78(5,0)/ 15°	0,22/-109°
2,4	0,77/108°	0,112(-19,0)/40°	1,63(4,3)/ 10°	0,21/-122°
2,6	0,79/103°	0,123(-18,2)/37°	1,51(3,6)/ 2°	0,24/-133°
2,8	0,80/ 97°	0,129(-17,8)/33°	1,36(2,7)/ -4°	0,25/-143°
3,0	0,81/ 92°	0,134(-17,5)/30°	1,28(2,1)/-11°	0,27/-151°
3,2	0,83/ 88°	0,143(-16,9)/26°	1,15(1,2)/-17°	0,28/-163°
3,4	0,85/ 85°	0,152(-16,4)/24°	1,10(0,9)/-21°	0,30/-173°
3,6	0,86/ 82°	0,163(-15,8)/20°	1,00(0)/-28°	0,34/+178°
3,8	0,87/ 79°	0,168(-15,5)/17°	0,96(-0,4)/-32°	0,37/+173°
4,0	0,88/ 75°	0,175(-15,2)/14°	0,88(-1,1)/-39°	0,41/+168°
4,2	0,88/ 71°	0,180(-14,9)/11°	0,83(-1,6)/-42°	0,42/+162°
4,4	0,89/ 69°	0,193(-14,3)/ 8°	0,79(-2,1)/-48°	0,45/+155°
4,6	0,90/ 66°	0,200(-14,0)/ 5°	0,74(-2,6)/-51°	0,48/+149°
4,8	0,90/ 64°	0,211(-13,5)/ 2°	0,71(-3,0)/-56°	0,52/+145°
5,0	0,90/ 61°	0,214(-13,4)/-2°	0,66(-3,6)/-59°	0,55/+144°

The figures given between brackets are values in dB.

* V_{CE} and I_C regulated.

APPLICATION INFORMATION

Microwave performance in c.w. operation for the LBE/LCE2003S up to $T_{mb} = 25\text{ }^\circ\text{C}$ in an unneutralized common-emitter class-A circuit*.

f GHz	V_{CE} (1) V	I_C (1) mA	P_{L1} (2) mW(dBm)	G_{po} (3) dB	\bar{z}_i Ω	\bar{z}_L Ω
2	18	30	≥ 200 (23) typ. 250(24)	≥ 10 typ. 11	$6,2 + j30$	$17,5 + j7$

Notes

1. V_{CE} and I_C regulated.
2. Load power for 1 dB compressed power gain.
3. Low-level power gain associated with P_{L1} .

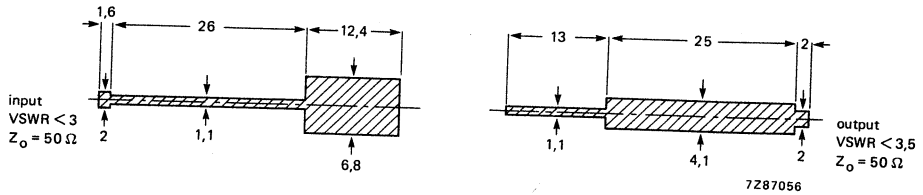

Fig. 6 Prematching test circuit board for 2 GHz. (Dimensions in mm.)

Striplines on a double Cu-clad printed-circuit board with PTFE fibre-glass dielectric ($\epsilon_r \approx 2,54$); thickness 0,8 mm.

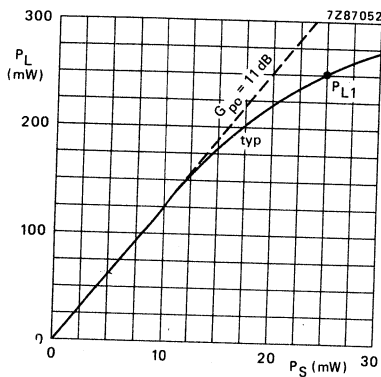

Fig. 7 $V_{CE} = 18\text{ V}$; $I_C = 30\text{ mA}$;
 $f = 2\text{ GHz}$; $T_{mb} = 25\text{ }^\circ\text{C}$.

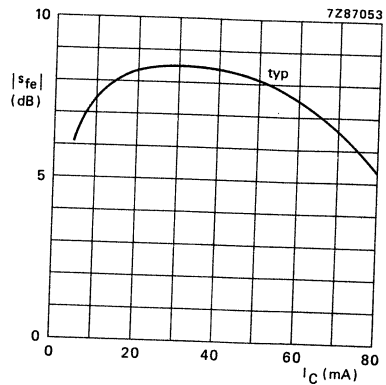

Fig. 8 $V_{CE} = 18\text{ V}$; class-A
operation; $f = 2\text{ GHz}$; $T_{mb} = 25\text{ }^\circ\text{C}$.

* Circuit consists of prematching circuit board in combination with input and output slug tuners.

APPLICATION INFORMATION

Microwave performance in c.w. operation for the LBE/LCE2009S up to $T_{mb} = 25\text{ }^{\circ}\text{C}$ in an unneutralized common-emitter class-A circuit*.

f GHz	V_{CE} (1) V	I_C (1) mA	P_{L1} (2) mW(dBm)	G_{po} (3) dB	\bar{z}_i Ω	\bar{z}_L Ω
2	18	100	$\geq 700(28,5)$ typ. 900(29,5)	≥ 9 typ. 9,8	$7,5 + j14,5$	$17,5 + j38,5$

Notes

- V_{CE} and I_C regulated.
- Load power for 1 dB compressed power gain.
- Low-level power gain associated with P_{L1} .

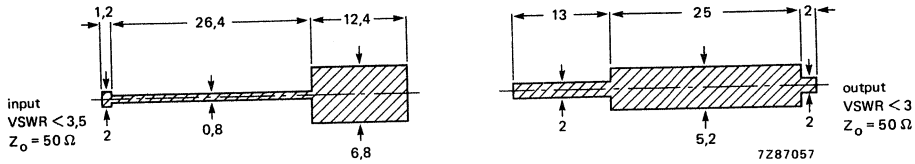

Fig. 9 Prematching test circuit board for 2 GHz. (Dimensions in mm.)

Striplines on a double Cu-clad printed-circuit board with PTFE fibre-glass dielectric ($\epsilon_r \approx 2,54$); thickness 0,8 mm.

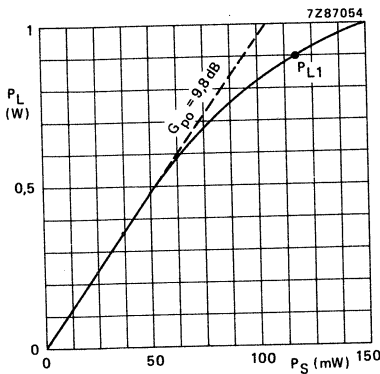

Fig. 10 $V_{CE} = 18\text{ V}$; $I_C = 110\text{ mA}$;
 $f = 2\text{ GHz}$; $T_{mb} = 25\text{ }^{\circ}\text{C}$.

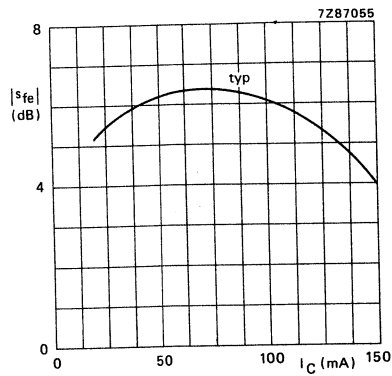

Fig. 11 $V_{CE} = 18\text{ V}$; class-A
operation; $f = 2\text{ GHz}$; $T_{mb} = 25\text{ }^{\circ}\text{C}$.

* Circuit consists of prematching circuit board in combination with input and output slug tuners.

MICROWAVE LINEAR POWER TRANSISTOR

N-P-N transistor for use in a common-emitter class-A linear power amplifier up to 1 GHz.
Diffused emitter ballasting resistors, interdigitated structure, multicell geometry and gold sandwich metallization ensure an optimum temperature profile and excellent performance and reliability.

QUICK REFERENCE DATA

R.F. performance up to $T_{mb} = 25\text{ }^{\circ}\text{C}$ in an unneutralized common-emitter class-A circuit.

mode of operation	f GHz	V_{CE} V	I_C mA	P_{L1} mW	G_{po} dB	\bar{z}_i Ω	\bar{Z}_L Ω
c.w.; linear amplifier	1	15	100	typ. 400	typ. 11	$6,5 + j4$	$13 + j23$

MECHANICAL DATA see page 2

This data must be read in conjunction with GENERAL SAFETY RECOMMENDATIONS – MICROWAVE SEMICONDUCTORS.

POTENTIAL HAZARD-BERYLLIUM OXIDE

This device contains beryllium oxide, the dust of which is toxic. The device is entirely safe, provided that the beryllium oxide disc is not damaged. Care should be taken to ensure that all those who may handle, use or dispose of this device are aware of its nature and of the necessary safety precautions. In particular, it should never be thrown out with general industrial or domestic waste.



MECHANICAL DATA

Fig. 1. FO-53
Emitter connected
to flange.

Dimensions in mm

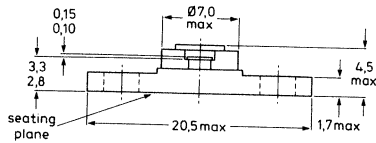

Torque on nut: max. 0,5 Nm
Recommended screw: M3

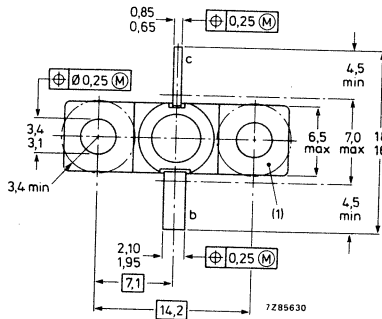

Marking code
RTC112 = LKE1004R

(1) Flatness of this area ensures full thermal contact with bolt head.

RATINGS

Limiting values in accordance with the Absolute Maximum System (IEC 134)

Collector-base voltage (open emitter)	V_{CBO}	max.	30 V
Collector-emitter voltage ($R_{BE} \leq 500 \Omega$) (open base)	V_{CER}	max.	30 V
Emitter-base voltage (open collector)	V_{CEO}	max.	14 V
Collector current (d.c.)	V_{EBO}	max.	3 V
Total power dissipation up to $T_{mb} = 75 \text{ }^\circ\text{C}$	I_C	max.	400 mA
Storage temperature	P_{tot}	max.	3 W
Junction temperature	T_{stg}		-65 to +200 $^\circ\text{C}$
Lead soldering temperature at 0,3 mm from the case; $t_{sld} \leq 10 \text{ s}$	T_j	max.	200 $^\circ\text{C}$
	T_{sld}	max.	235 $^\circ\text{C}$

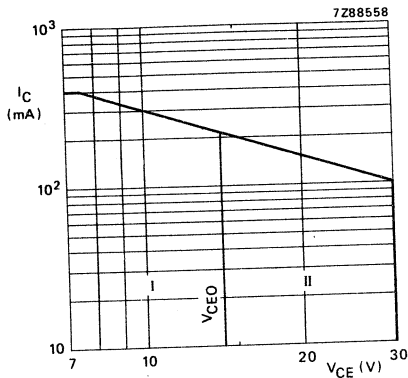

(1) Second breakdown limit (independent of temperature).

Fig. 2 D.C. SOAR at $T_{mb} \leq 75^\circ\text{C}$.

- I Region of permissible d.c. operation.
- II Permissible extension provided $R_{BE} \leq 500 \Omega$.

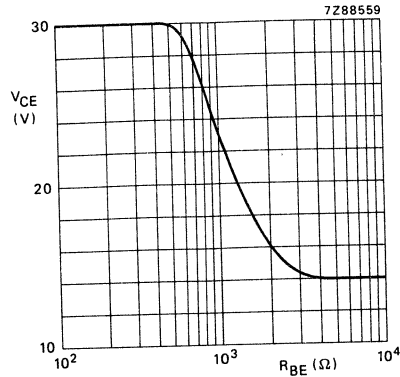

Fig. 3 Maximum permissible collector-emitter voltage as a function of R_{BE} .

THERMAL RESISTANCE

From junction to mounting base
 From mounting base to heatsink

$R_{th\ j-mb}$	=	30 °C/W
$R_{th\ mb-h}$	=	0.7 °C/W

CHARACTERISTICS

$T_{mb} = 25^\circ\text{C}$

Collector-base breakdown voltage
 open emitter; $I_C = 0,5\ \text{mA}$

Collector-emitter breakdown voltage
 $R_{BE} = 500\ \Omega$; $I_C = 5\ \text{mA}$
 open base; $-I_E = 5\ \text{mA}$

Emitter-base breakdown voltage
 open collector; $I_E = 1\ \text{mA}$

Collector cut-off current
 $I_E = 0$; $V_{CB} = 20\ \text{V}$

Emitter cut-off current
 $I_C = 0$; $V_{EB} = 2\ \text{V}$

D.C. current gain
 $I_C = 75\ \text{mA}$; $V_{CE} = 5\ \text{V}$

Collector-base capacitance at $f = 1\ \text{MHz}$
 $I_E = I_C = 0$; $V_{CB} = 14\ \text{V}$

Collector-emitter capacitance at $f = 1\ \text{MHz}$
 $I_E = I_C = 0$; $V_{CE} = 14\ \text{V}$

$V_{(BR)CBO}$	\geq	30 V
$V_{(BR)CER}$	\geq	30 V
$V_{(BR)CEO}$	\geq	14 V
$V_{(BR)EBO}$	\geq	3 V
I_{CBO}	$<$	0,2 mA
I_{EBO}	$<$	0,2 mA
h_{FE}	$>$	20
C_{cb}	typ.	1,5 pF
C_{ce}	typ.	2,2 pF

Emitter-base capacitance at $f = 1$ MHz

$I_E = I_C = 0; V_{EB} = 1$ V

C_{eb} typ. 4,4 pF

Forward power gain

$V_{CE} = 15$ V; $I_C = 100$ mA; $f = 1$ GHz

$|s_{fe}|^2$ typ. 6 dB

Maximum available power gain

$V_{CE} = 15$ V; $I_C = 100$ mA; $f = 1$ GHz

G_{AM} typ. 11 dB

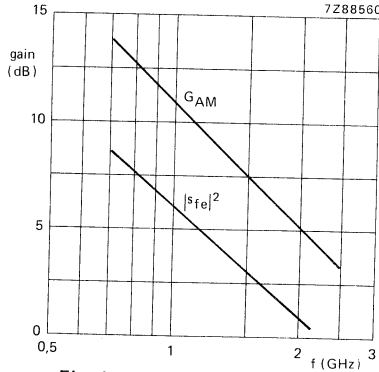

Fig. 4 V_{CE} and I_C regulated.

Typical values; $V_{CE} = 15$ V;
 $I_C = 100$ mA; $T_{mb} = 25$ °C.

s-parameters (common-emitter)

Typical values; $V_{CE} = 15$ V*; $I_C = 100$ mA*; $Z_0 = 50$ Ω.

f GHz	s_{ie}	s_{re}	s_{fe}	s_{oe}
0,75	0,72/170°	0,07(-23)/35°	2,24(7,0)/80°	0,52/-145°
1	0,71/165°	0,08(-22)/40°	2,00(6,0)/70°	0,52/-152°
1,5	0,67/151°	0,10(-20)/43°	1,33(2,5)/52°	0,52/-156°
2	0,61/134°	0,14(-17)/40°	1,12(1,0)/30°	0,52/-160°
2,5	0,61/ 89°	0,15(-16)/35°	1,05(0,5)/15°	0,52/-162°

The figures given between brackets are values in dB.

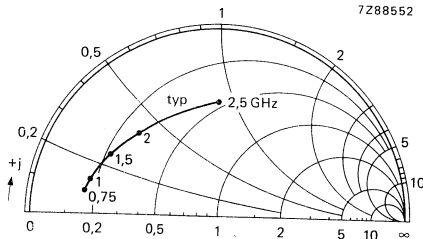

Fig. 5 Input reflection coefficient s_{ie} .

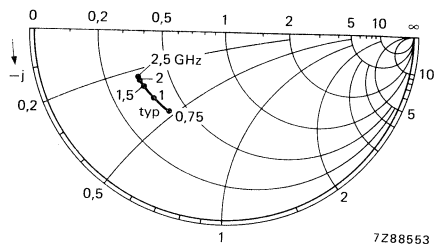

Fig. 6 Output reflection coefficient s_{oe} .

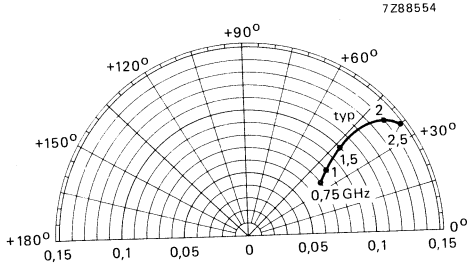

Fig. 7 Reverse transmission coefficient s_{re} .

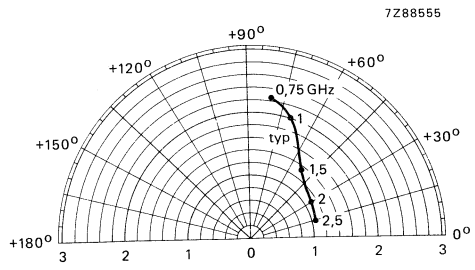

Fig. 8 Forward transmission coefficient s_{fe} .

Conditions for Figs 5 up to 8:

Typical values; $V_{CE} = 15 \text{ V}^*$; $I_C = 100 \text{ mA}^*$; $T_{mb} = 25 \text{ }^\circ\text{C}$; $Z_o = 50 \text{ } \Omega$.

* V_{CE} and I_C regulated.

APPLICATION INFORMATION

R.F. performance in c.w. operation up to $T_{mb} = 25 \text{ }^\circ\text{C}$ in an unneutralized common-emitter class-A circuit.

f GHz	V_{CE} (1) V	I_C (1) mA	P_{L1} (2) mW (dBm)	G_{po} (3) dB	P_{Lsat} (4) mW (dBm)
1	15	100	$\geq 320(25)$ typ. 400(26)	≥ 8 typ. 11	— typ. 630(28)

Notes

1. V_{CE} and I_C regulated.
2. Load power for 1 dB compressed power gain.
3. Low-level power gain associated with P_{L1} .
4. Saturated output power of the transistor.

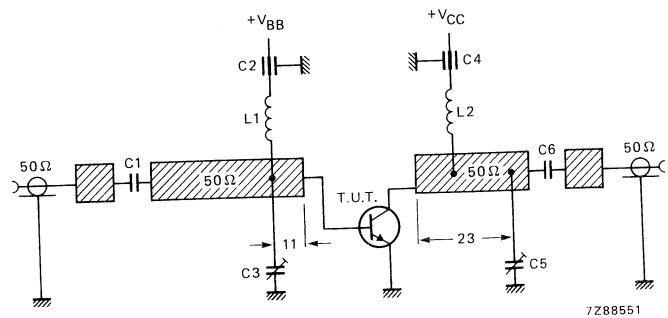

Fig. 9 Class-A test circuit at $f = 1 \text{ GHz}$. (Dimensions in mm.)

List of components:

C1 = C6 = 1 nF multilayer ceramic chip capacitor

C2 = C4 = 500 pF ceramic feed-through capacitor

C3 = C5 = 0 to 10 pF film dielectric trimmer

L1 = L2 = 5 turns enamelled Cu wire (0,5 mm); internal diameter 2,5 mm

Striplines on a double Cu-clad printed-circuit board with PTFE fibre-glass dielectric ($\epsilon_r = 2,54$); thickness 0,8 mm.

Conditions for Figs 10 up to 13:

$V_{CE} = 15\text{ V}$
 $I_C = 100\text{ mA}$ } regulated; $T_{mb} = 25\text{ }^\circ\text{C}$

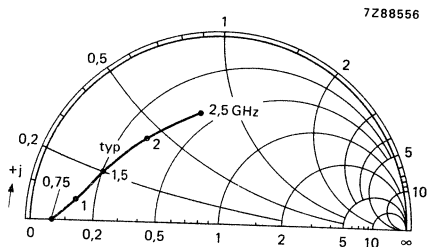

Fig. 10 Input impedance as a function of frequency for P_{L1} .

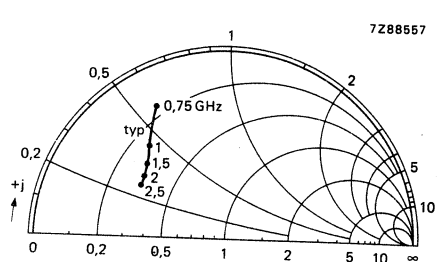

Fig. 11 Optimum load impedance as a function of frequency for P_{L1} .

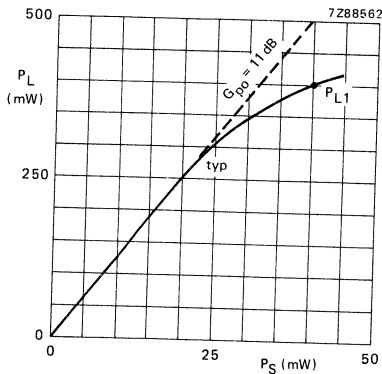

Fig. 12 Load power as a function of source power at $f = 1\text{ GHz}$.

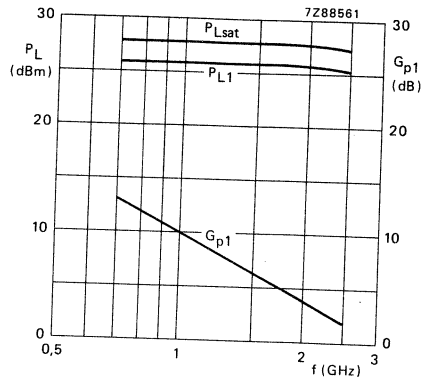

Fig. 13 P_{Lsat} , P_{L1} and G_{p1} associated with P_{L1} as a function of frequency.

MICROWAVE LINEAR POWER TRANSISTOR

N-P-N transistor for use in a common-emitter class-A linear power amplifier up to 2 GHz.

Diffused emitter ballasting resistors, interdigitated structure, multicell geometry and gold sandwich metallization ensure an optimum temperature profile and excellent performance and reliability.

QUICK REFERENCE DATA

R.F. performance up to $T_{mb} = 25\text{ }^{\circ}\text{C}$ in an unneutralized common-emitter class-A circuit

mode of operation	f GHz	V_{CE} V	I_C mA	P_{L1} W	G_{po} dB	\bar{z}_i Ω	\bar{z}_L Ω
c.w.; linear amplifier	2	20	200	typ. 1,6	typ. 8	2,5 + j12	4 + j4

see page 2

MECHANICAL DATA

This data must be read in conjunction with GENERAL SAFETY RECOMMENDATIONS—MICROWAVE SEMICONDUCTORS.

POTENTIAL HAZARD—BERYLLIUM OXIDE

This device contains beryllium oxide, the dust of which is toxic. The device is entirely safe, provided that the beryllium oxide disc is not damaged. Care should be taken to ensure that all those who may handle, use or dispose of this device are aware of its nature and of the necessary safety precautions. In particular, it should never be thrown out with general industrial or domestic waste.



MECHANICAL DATA

Fig. 1.

Emitter connected
to flange

Dimensions in mm

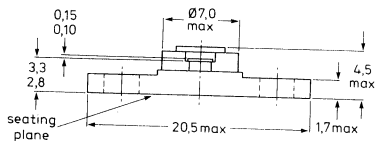

Torque on nut: max. 0,5 Nm

Recommended screw: M3

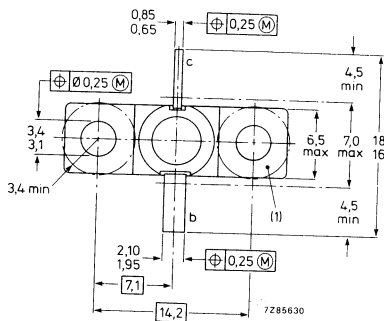

Marking code

RTC144 = LKE2015T

(1) Flatness of this area ensures full thermal contact with bolt head.



RATINGS

Limiting values in accordance with the Absolute Maximum System (IEC 134)

Collector-base voltage (open emitter)	V_{CBO}	max.	45 V
Collector-emitter voltage ($R_{BE} = 120 \Omega$) (open base)	V_{CER} V_{CEO}	max.	25 V 20 V
Emitter-base voltage (open collector)	V_{EBO}	max.	3,5 V
Collector current (d.c.)	I_C	max.	800 mA
Total power dissipation up to $T_{mb} = 75 \text{ }^\circ\text{C}$	P_{tot}	max.	8 W
Storage temperature	T_{stg}		-65 to + 200 $^\circ\text{C}$
Junction temperature	T_j	max.	200 $^\circ\text{C}$
Lead soldering temperature at 0,3 mm from the case; $t_{sld} \leq 10 \text{ s}$	T_{sld}	max.	235 $^\circ\text{C}$

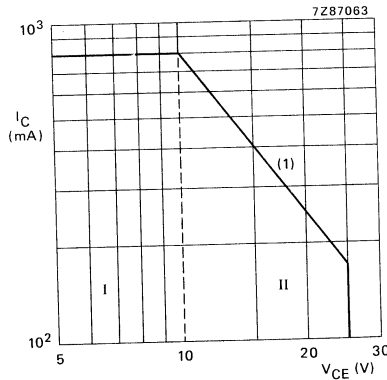

(1) Second breakdown limit (independent of temperature).

Fig. 2 D.C. SOAR at $T_{mb} \leq 75 \text{ }^\circ\text{C}$.

- I Region of permissible d.c. operation.
- II Permissible extension provided $R_{BE} \leq 120 \Omega$.

THERMAL RESISTANCE

From junction to mounting base
From mounting base to heatsink

$R_{th \text{ j-mb}}$	=	11 $^\circ\text{C/W}$
$R_{th \text{ mb-h}}$	=	0,7 $^\circ\text{C/W}$

CHARACTERISTICS

$T_{mb} = 25\text{ }^{\circ}\text{C}$

Collector-base breakdown voltage
open emitter; $I_C = 3\text{ mA}$

$V_{(BR)CBO} \geq 45\text{ V}$

Collector-emitter breakdown voltage
 $R_{BE} = 120\text{ }\Omega$; $I_C = 15\text{ mA}$
open base; $-I_E = 15\text{ mA}$

$V_{(BR)CER} \geq 25\text{ V}$

$V_{(BR)CEO} \geq 20\text{ V}$

Emitter-base breakdown voltage
open collector; $I_E = 1\text{ mA}$

$V_{(BR)EBO} \geq 3,5\text{ V}$

Collector cut-off current
 $I_E = 0$; $V_{CB} = 20\text{ V}$

$I_{CBO} < 0,5\text{ }\mu\text{A}$

Emitter cut-off current
 $I_C = 0$; $V_{EB} = 1,5\text{ V}$

$I_{EBO} < 300\text{ }\mu\text{A}$

D.C. current gain
 $I_C = 200\text{ mA}$; $V_{CE} = 5\text{ V}$

$h_{FE} \quad 15\text{ to }150$

Collector-base capacitance at $f = 1\text{ MHz}$
 $I_E = I_C = 0$; $V_{CB} = 20\text{ V}$; $V_{EB} = 1,5\text{ V}$

$C_{cb} \quad \text{typ. } 3,5\text{ pF}$

Collector-emitter capacitance at $f = 1\text{ MHz}$
 $I_E = I_C = 0$; $V_{CE} = 20\text{ V}$; $V_{EB} = 1,5\text{ V}$

$C_{ce} \quad \text{typ. } 2,9\text{ pF}$

Emitter-base capacitance at $f = 1\text{ MHz}$
 $I_E = I_C = 0$; $V_{EB} = 1\text{ V}$; $V_{CB} = 10\text{ V}$

$C_{eb} \quad \text{typ. } 17\text{ pF}$

Forward power gain
 $V_{CE} = 20\text{ V}$; $I_C = 200\text{ mA}$; $f = 1\text{ GHz}$
 $V_{CE} = 20\text{ V}$; $I_C = 200\text{ mA}$; $f = 2\text{ GHz}$

$|s_{fe}|^2 \quad \text{typ. } 2,4\text{ dB}$

$|s_{fe}|^2 \quad \text{typ. } -3,1\text{ dB}$

Maximum available power gain
 $V_{CE} = 20\text{ V}$; $I_C = 200\text{ mA}$; $f = 1\text{ GHz}$
 $V_{CE} = 20\text{ V}$; $I_C = 200\text{ mA}$; $f = 2\text{ GHz}$

$G_{AM} \quad \text{typ. } 13,7\text{ dB}$

$G_{AM} \quad \text{typ. } 8,4\text{ dB}$

s-parameters (common-emitter)

$V_{CE} = 20\text{ V}$
 $I_C = 200\text{ mA}$ } regulated; $T_{mb} = 25\text{ }^\circ\text{C}$; typical values.

f GHz	S_{ie}	S_{re}	S_{fe}	S_{oe}
0,5	0,94/174°	0,021(-33,6)/27°	2,61(8,3)/72°	0,57/-173°
0,6	0,94/172°	0,022(-33,2)/30°	2,20(6,8)/68°	0,57/-176°
0,7	0,94/170°	0,023(-32,7)/33°	1,89(5,5)/63°	0,57/-177°
0,8	0,94/168°	0,025(-32,1)/35°	1,67(4,4)/59°	0,57/-178°
0,9	0,94/167°	0,027(-31,5)/37°	1,48(3,4)/54°	0,57/-179°
1,0	0,94/165°	0,028(-30,9)/38°	1,32(2,4)/49°	0,58/+180°
1,1	0,93/163°	0,030(-30,4)/39°	1,21(1,7)/46°	0,59/+178°
1,2	0,93/161°	0,033(-29,7)/41°	1,12(1,0)/42°	0,60/+178°
1,3	0,92/160°	0,035(-29,2)/42°	1,03(0,3)/38°	0,60/+177°
1,4	0,93/158°	0,036(-28,8)/43°	0,96(-0,4)/34°	0,61/+175°
1,5	0,93/156°	0,038(-28,4)/47°	0,90(-0,9)/32°	0,62/+175°
1,6	0,93/155°	0,044(-27,1)/48°	0,86(-1,3)/28°	0,62/+174°
1,7	0,94/152°	0,047(-26,5)/46°	0,83(-1,7)/23°	0,63/+173°
1,8	0,93/150°	0,050(-26,0)/44°	0,78(-2,2)/19°	0,64/+171°
1,9	0,93/148°	0,053(-25,5)/44°	0,74(-2,7)/16°	0,64/+171°
2,0	0,93/146°	0,056(-25,0)/43°	0,70(-3,1)/12°	0,64/+168°
2,1	0,92/144°	0,060(-24,5)/42°	0,67(-3,4)/ 9°	0,65/+166°
2,2	0,92/143°	0,064(-23,9)/41°	0,64(-3,8)/ 5°	0,66/+165°
2,3	0,92/141°	0,067(-23,5)/41°	0,61(-4,3)/ 2°	0,67/+163°
2,4	0,92/140°	0,071(-22,9)/39°	0,59(-4,5)/ 0°	0,68/+162°

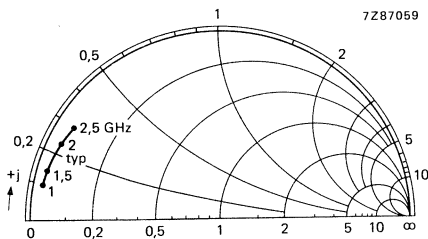

Fig. 3 Input impedance as a function of frequency for P_{L1} .

Conditions for Figs 3 and 4:

$V_{CE} = 20\text{ V}$
 $I_C = 200\text{ mA}$ } regulated; $T_{mb} = 25\text{ }^\circ\text{C}$; typical values.

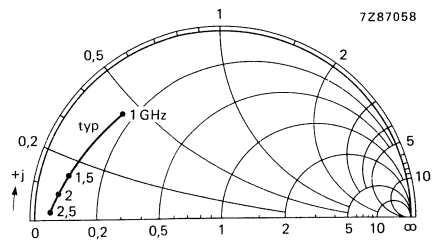

Fig. 4 Optimum load impedance as a function of frequency for P_{L1} .

APPLICATION INFORMATION

R.F. performance in c.w. operation up to $T_{mb} = 25\text{ }^\circ\text{C}$ in an unneutralized common-emitter class-A circuit*

f GHz	V_{CE} (1) V	I_C (1) mA	P_{L1} (2) mW(dBm)	G_{po} (3) dB	\bar{z}_i Ω	\bar{Z}_L Ω
2	20	200	≥ 1300 (31) typ. 1600(32)	$\geq 7,5$ typ. 8,0	$2,5 + j12$	$4 + j4$

Notes

1. V_{CE} and I_C regulated.
2. Load power for 1 dB compressed power gain.
3. Low-level power gain associated with P_{L1} .

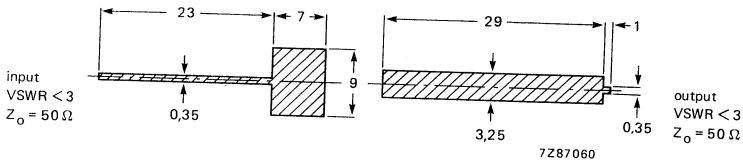

Fig. 5 Prematching test circuit board for 2 GHz. (Dimensions in mm.)

Striplines on a double Cu-clad printed-circuit board with PTFE fibre-glass dielectric ($\epsilon_r = 2,4$); thickness 0,25 mm.

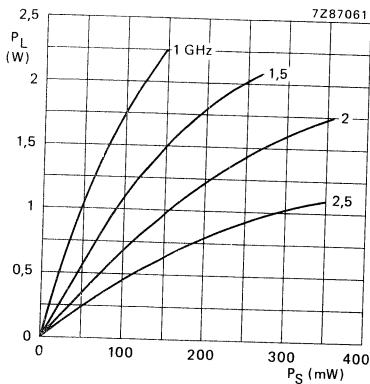

Fig. 6 Load power as a function of source power with frequency as parameter.

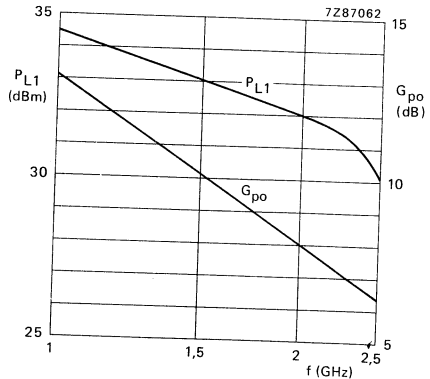

Fig. 7 Load power and power gain, associated with 1 dB compressed power gain, as a function of frequency.

Conditions for Figs 6 and 7:

$V_{CE} = 20\text{ V}$
 $I_C = 200\text{ mA}$ } regulated; $T_{mb} = 25\text{ }^\circ\text{C}$; typical values.

* Circuit consists of prematching circuit board in combination with complementary input and output slug tuners.

MICROWAVE LINEAR POWER TRANSISTOR

N-P-N transistor for use in a common-emitter class-A linear power amplifier up to 2,1 GHz.

Diffused emitter ballasting resistors, interdigitated structure, multicell geometry and gold sandwich metallization ensure an optimum temperature profile and excellent performance and reliability.

QUICK REFERENCE DATA

R.F. performance up to $T_{mb} = 25\text{ }^{\circ}\text{C}$ in an unneutralized common-emitter class-A circuit

mode of operation	f GHz	V_{CE} V	I_C mA	P_{L1} mW	G_{po} dB	\bar{z}_i Ω	\bar{z}_L Ω
c.w.; linear amplifier	2,1	15	140	typ. 600	typ. 10	$6 + j8$	$4 + j8$

This data must be read in conjunction with GENERAL SAFETY RECOMMENDATIONS – MICROWAVE SEMICONDUCTORS

MECHANICAL DATA

see page 2

POTENTIAL HAZARD—BERYLLIUM OXIDE

This device contains beryllium oxide, the dust of which is toxic. The device is entirely safe, provided that the beryllium oxide disc is not damaged. Care should be taken to ensure that all those who may handle, use or dispose of this device are aware of its nature and of the necessary safety precautions. In particular, it should never be thrown out with general industrial or domestic waste.



MECHANICAL DATA

Fig. 1.

Emitter connected to flange

Dimensions in mm

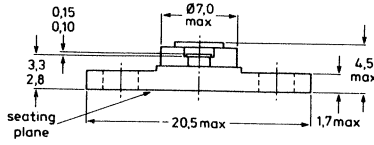

Torque on nut: max. 0,5 Nm

Recommended screw: M3

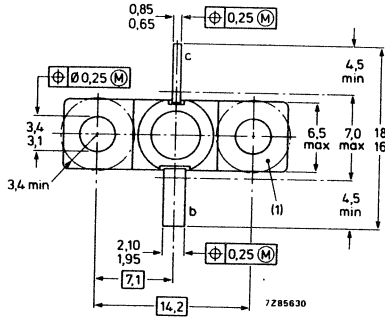

Marking code

RTC146 = LKE21004R

(1) Flatness of this area ensures full thermal contact with bolt head.



RATINGS

Limiting values in accordance with the Absolute Maximum System (IEC 134)

Collector-base voltage (open emitter)	V_{CBO}	max.	30 V
Collector-emitter voltage ($R_{BE} = 500 \Omega$)	V_{CER}	max.	20 V
(open base)	V_{CEO}	max.	14 V
Emitter-base voltage (open collector)	V_{EBO}	max.	3 V
Collector current (d.c.)	I_C	max.	600 mA
Total power dissipation up to $T_{mb} = 75 \text{ }^\circ\text{C}$	P_{tot}	max.	2,8 W
Storage temperature	T_{stg}		-65 to + 200 $^\circ\text{C}$
Junction temperature	T_j	max.	200 $^\circ\text{C}$
Lead soldering temperature at 0,3 mm from the case; $t_{slid} \leq 10 \text{ s}$	T_{slid}	max.	235 $^\circ\text{C}$

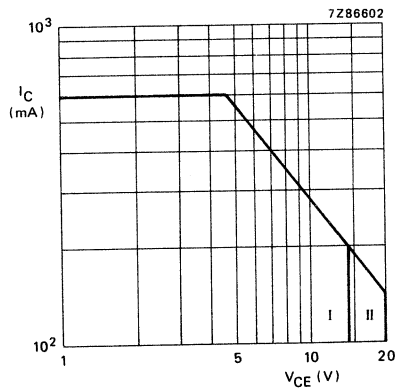

Fig. 2 D.C. SOAR at $T_{mb} \leq 75 \text{ }^\circ\text{C}$.

- I Region of permissible d.c. operation.
- II Permissible extension provided $R_{BE} \leq 500 \Omega$.

THERMAL RESISTANCE

From junction to mounting base	$R_{th \text{ j-mb}}$	=	22 $^\circ\text{C/W}$
From mounting base to heatsink	$R_{th \text{ mb-h}}$	=	0,7 $^\circ\text{C/W}$

CHARACTERISTICS

$T_{mb} = 25\text{ }^{\circ}\text{C}$

Collector-base breakdown voltage
open emitter; $I_C = 1\text{ mA}$

$V_{(BR)CBO} \geq 30\text{ V}$

Collector-emitter breakdown voltage
 $R_{BE} = 500\text{ }\Omega$; $I_C = 10\text{ mA}$
open base; $-I_E = 10\text{ mA}$

$V_{(BR)CER} \geq 20\text{ V}$

$V_{(BR)CEO} \geq 14\text{ V}$

Emitter-base breakdown voltage
open collector; $I_E = 1\text{ mA}$

$V_{(BR)EBO} \geq 3\text{ V}$

Collector cut-off current
 $I_E = 0$; $V_{CB} = 15\text{ V}$

$I_{CBO} < 100\text{ }\mu\text{A}$

D.C. current gain

$I_C = 140\text{ mA}$; $V_{CE} = 5\text{ V}$

$h_{FE} \quad 15\text{ to }150$

Collector-base capacitance at $f = 1\text{ MHz}$

$I_E = I_C = 0$; $V_{CB} = 15\text{ V}$; $V_{EB} = 1,5\text{ V}$

$C_{cb} \quad \text{typ. } 2,7\text{ pF}$

Collector-emitter capacitance at $f = 1\text{ MHz}$

$I_E = I_C = 0$; $V_{CE} = 15\text{ V}$; $V_{EB} = 1,5\text{ V}$

$C_{ce} \quad \text{typ. } 2,5\text{ pF}$

Emitter-base capacitance at $f = 1\text{ MHz}$

$I_E = I_C = 0$; $V_{EB} = 1\text{ V}$; $V_{CB} = 10\text{ V}$

$C_{eb} \quad \text{typ. } 27\text{ pF}$

s-parameters (common-emitter)

$V_{CE} = 15\text{ V}$ |
 $I_C = 125\text{ mA}$ | regulated; $T_{mb} = 25\text{ }^{\circ}\text{C}$; typical values.

f GHz	s_{ie}	s_{re}	s_{fe}	s_{oe}
2,0	0,92/170 $^{\circ}$	0,015(-36,4)/-103 $^{\circ}$	1,10(+0,85)/ -76 $^{\circ}$	0,94/-171 $^{\circ}$
2,1	0,94/168 $^{\circ}$	0,007(-43,4)/-118 $^{\circ}$	0,94(-0,57)/ -85 $^{\circ}$	0,94/-177 $^{\circ}$
2,2	0,95/166 $^{\circ}$	0,001(-59,4)/-144 $^{\circ}$	0,79(-2,09)/ -93 $^{\circ}$	0,93/+179 $^{\circ}$
2,3	0,97/167 $^{\circ}$	0,001(-64,3)/-172 $^{\circ}$	0,67(-3,54)/-101 $^{\circ}$	0,92/+175 $^{\circ}$
2,4	0,98/166 $^{\circ}$	0,002(-55,1)/+159 $^{\circ}$	0,57(-4,89)/-106 $^{\circ}$	0,91/+173 $^{\circ}$
2,5	0,99/166 $^{\circ}$	0,003(-50,9)/+127 $^{\circ}$	0,50(-6,0)/-113 $^{\circ}$	0,89/+171 $^{\circ}$
2,6	0,99/164 $^{\circ}$	0,003(-50,1)/+101 $^{\circ}$	0,44(-7,1)/-117 $^{\circ}$	0,87/+169 $^{\circ}$
2,7	0,99/163 $^{\circ}$	0,004(-48,3)/+101 $^{\circ}$	0,38(-8,5)/-124 $^{\circ}$	0,84/+167 $^{\circ}$
2,8	0,99/162 $^{\circ}$	0,009(-41,1)/+90 $^{\circ}$	0,33(-9,7)/-130 $^{\circ}$	0,81/+163 $^{\circ}$
2,9	0,98/157 $^{\circ}$	0,011(-39,1)/+75 $^{\circ}$	0,28(-11,1)/-138 $^{\circ}$	0,79/+158 $^{\circ}$
3,0	0,98/157 $^{\circ}$	0,015(-36,6)/+69 $^{\circ}$	0,24(-12,2)/-144 $^{\circ}$	0,77/+157 $^{\circ}$
3,1	0,97/156 $^{\circ}$	0,021(-33,4)/+75 $^{\circ}$	0,22(-13,2)/-149 $^{\circ}$	0,77/+155 $^{\circ}$
3,2	0,96/158 $^{\circ}$	0,022(-33,4)/+68 $^{\circ}$	0,16(-15,9)/-157 $^{\circ}$	0,73/+154 $^{\circ}$
3,3	0,96/155 $^{\circ}$	0,024(-32,5)/+69 $^{\circ}$	0,15(-16,5)/-160 $^{\circ}$	0,72/+153 $^{\circ}$
3,4	0,97/153 $^{\circ}$	0,021(-33,4)/+63 $^{\circ}$	0,14(-17,2)/-165 $^{\circ}$	0,72/+152 $^{\circ}$
3,5	0,98/152 $^{\circ}$	0,024(-32,4)/+61 $^{\circ}$	0,12(-18,4)/-170 $^{\circ}$	0,70/+151 $^{\circ}$

APPLICATION INFORMATION

R.F. performance in c.w. operation up to $T_{mb} = 25\text{ }^{\circ}\text{C}$ in an unneutralized common-emitter class-A circuit*

f GHz	V_{CE} (1) V	I_C (1) mA	P_{L1} (2) mW(dBm)	G_{po} (3) dB	\bar{z}_i Ω	\bar{Z}_L Ω
2,1	15	140	$\geq 400(26)$ typ. 600(27,8)	$\geq 8,5$ typ. 10	$6 + j8$	$4 + j8$

Notes

- V_{CE} and I_C regulated.
- Load power for 1 dB compressed power gain.
- Low-level power gain associated with P_{L1} .

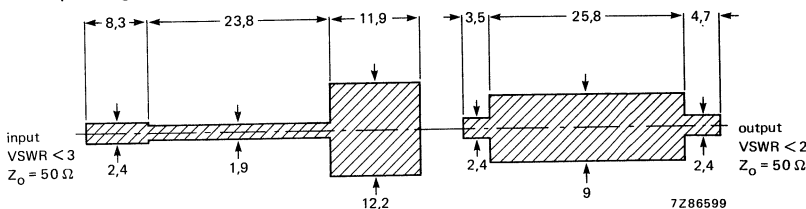

Fig. 3 Prematching test circuit board for 2,1 GHz. (Dimensions in mm.)

Striplines on a double Cu-clad printed-circuit board with PTFE fibre-glass dielectric ($\epsilon_r = 2,54$); thickness 0,8 mm.

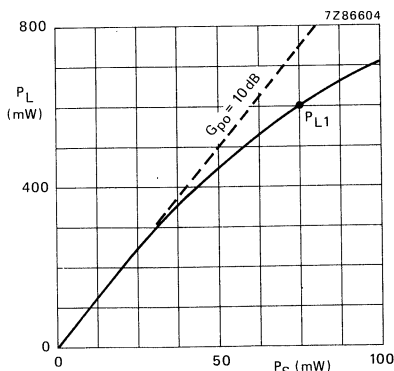

Fig. 4 Load power as a function of source power. Typical values;
 $V_{CE} = 15\text{ V}$ } regulated;
 $I_C = 140\text{ mA}$ }
 $f = 2,1\text{ GHz}$; $T_{mb} = 25\text{ }^{\circ}\text{C}$.

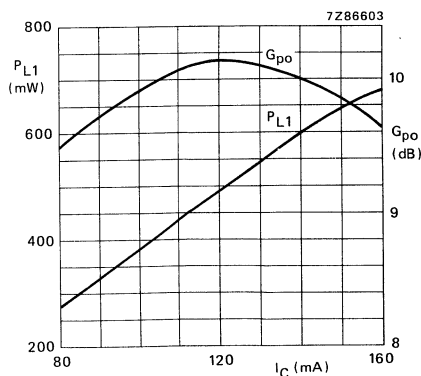

Fig. 5 Load power and power gain, associated with 1 dB compressed power gain, as a function of collector current.
 Typical values; $V_{CE} = 15\text{ V}$ regulated;
 $f = 2,1\text{ GHz}$; $T_{mb} = 25\text{ }^{\circ}\text{C}$.

* Circuit consists of prematching circuit board in combination with complementary input and output slug tuners.

MICROWAVE LINEAR POWER TRANSISTOR

N-P-N transistor for use in a common-emitter class-A linear power amplifier up to 2,1 GHz.

Diffused emitter ballasting resistors, interdigitated structure, multicell geometry and gold sandwich metallization ensure an optimum temperature profile and excellent performance and reliability.

An internal input matching network facilitates wideband operation.

QUICK REFERENCE DATA

R.F. performance up to $T_{mb} = 25\text{ }^{\circ}\text{C}$ in an unneutralized common-emitter class-A circuit

mode of operation	f GHz	V_{CE} V	I_C A	P_{L1} W	G_{po} dB	\bar{z}_i Ω	\bar{z}_L Ω
c.w.; linear amplifier	2,1	20	1,2	typ. 5,5	typ. 9	2,5 + j8	2,5 - j7

This data must be read in conjunction with GENERAL SAFETY RECOMMENDATIONS –
MICROWAVE SEMICONDUCTORS

MECHANICAL DATA

see page 2

POTENTIAL HAZARD—BERYLLIUM OXIDE

This device contains beryllium oxide, the dust of which is toxic. The device is entirely safe, provided that the beryllium oxide disc is not damaged. Care should be taken to ensure that all those who may handle, use or dispose of this device are aware of its nature and of the necessary safety precautions. In particular, it should never be thrown out with general industrial or domestic waste.

MECHANICAL DATA

Dimensions in mm

Fig. 1.

Emitter connected to flange.

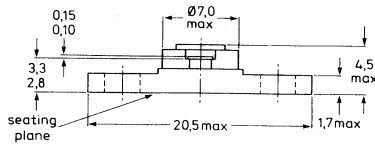

Torque on nut: max. 0,5 Nm

Recommended screw: M3

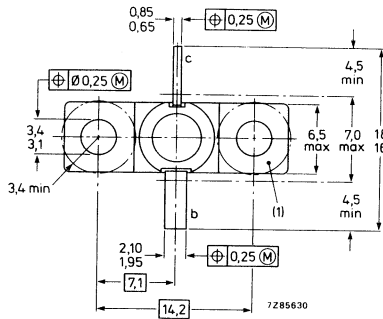

Marking code

RTC190 = LKE21050T

(1) Flatness of this area ensures full thermal contact with bolt head.



RATINGS

Limiting values in accordance with the Absolute Maximum System (IEC 134)

Collector-base voltage (open emitter)	V_{CBO}	max.	45 V
Collector-emitter voltage ($R_{BE} = 47 \Omega$)	V_{CER}	max.	40 V
(open base)	V_{CEO}	max.	22 V
Emitter-base voltage (open collector)	V_{EBO}	max.	3,5 V
Collector current (d.c.)	I_C	max.	3 A
Total power dissipation up to $T_{mb} = 75 \text{ }^\circ\text{C}$	P_{tot}	max.	30 W
Storage temperature	T_{stg}		-65 to +200 $^\circ\text{C}$
Junction temperature	T_j	max.	200 $^\circ\text{C}$
Lead soldering temperature at 0,3 mm from the case; $t_{slid} \leq 10 \text{ s}$	T_{slid}	max.	235 $^\circ\text{C}$

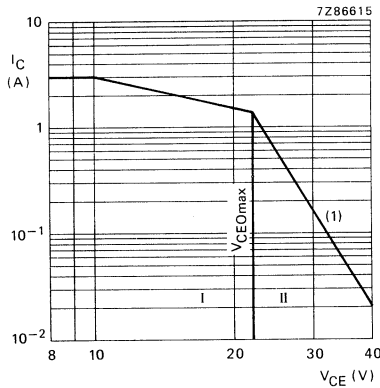

(1) Second breakdown limit (independent of temperature).

Fig. 2 D.C. SOAR at $T_{mb} \leq 75 \text{ }^\circ\text{C}$.

I Region of permissible d.c. operation.

II Permissible extension provided $R_{BE} \leq 47 \Omega$.

THERMAL RESISTANCE

From junction to mounting base

$R_{th \text{ j-mb}} = 4 \text{ }^\circ\text{C/W}$

From mounting base to heatsink

$R_{th \text{ mb-h}} = 0,7 \text{ }^\circ\text{C/W}$

CHARACTERISTICS

$T_{mb} = 25\text{ }^{\circ}\text{C}$

Collector-base breakdown voltage
open emitter; $I_C = 10\text{ mA}$

Emitter-base breakdown voltage
open collector; $I_E = 2\text{ mA}$

Collector cut-off current
 $I_E = 0$; $V_{CB} = 20\text{ V}$

D.C. current gain
 $I_C = 500\text{ mA}$; $V_{CE} = 5\text{ V}$

Collector-base capacitance at $f = 1\text{ MHz}$
 $I_E = I_C = 0$; $V_{CB} = 20\text{ V}$; $V_{EB} = 1\text{ V}$

Collector-emitter capacitance at $f = 1\text{ MHz}$
 $I_E = I_C = 0$; $V_{CE} = 20\text{ V}$; $V_{EB} = 1\text{ V}$

Emitter-base capacitance at $f = 1\text{ MHz}$
 $I_E = I_C = 0$; $V_{EB} = 1\text{ V}$; $V_{CB} = 15\text{ V}$

$V_{(BR)CBO} \geq 45\text{ V}$

$V_{(BR)EBO} \geq 3,5\text{ V}$

$I_{CBO} < 75\text{ }\mu\text{A}$

$h_{FE} \quad 20\text{ to }120$

$C_{cb} \quad \text{typ.} \quad 9\text{ pF}$

$C_{ce} \quad \text{typ.} \quad 5\text{ pF}$

$C_{eb} \quad \text{typ.} \quad 95\text{ pF}$

APPLICATION INFORMATION

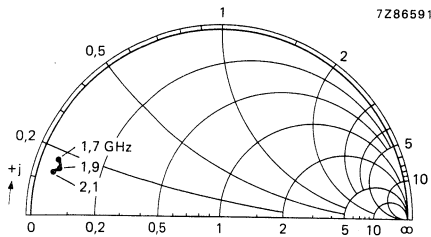

Fig. 3 Input impedance as a function of frequency for P_{L1} .

Conditions for Figs 3 and 4:

$V_{CE} = 20\text{ V}$
 $I_C = 1,2\text{ A}$ } regulated; typical values; $T_{mb} = 25\text{ }^{\circ}\text{C}$.

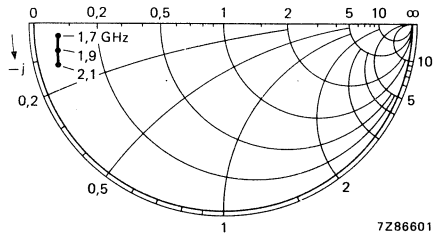

Fig. 4 Optimum load impedance as a function of frequency for P_{L1} .

APPLICATION INFORMATION (continued)

R.F. performance in c.w. operation up to $T_{mb} = 25\text{ }^{\circ}\text{C}$ in an unneutralized common-emitter class-A circuit*.

f GHz	V_{CE} (1) V	I_C (1) A	P_{L1} (2) mW	P_{po} (3) dB	\bar{z}_i Ω	\bar{z}_L Ω
2,1	20	1,2	≥ 5 typ. 5,5	≥ 7 typ. 9	$2,5 + j8$	$2,5 - j7$

Notes

1. V_{CE} and I_C regulated.
2. Load power for 1 dB compressed power gain.
3. Low-level power gain associated with P_{L1} .

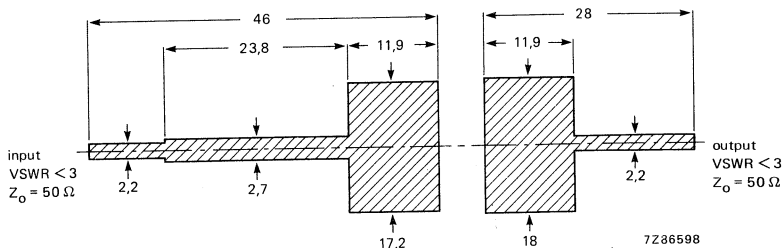

Fig. 5 Prematching test circuit board for 1,7 to 2,1 GHz. (Dimensions in mm.)

Striplines on a double Cu-clad printed-circuit board with PTFE fibre-glass dielectric ($\epsilon_r = 2,5$); thickness 0,8 mm.

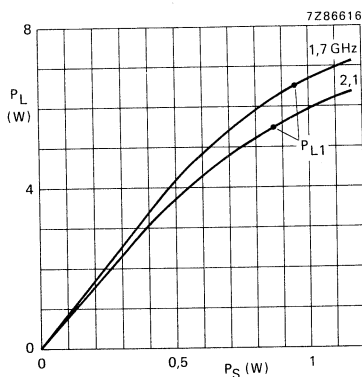

Fig. 6 Load power as a function of source power. Typ. values; $T_{mb} = 25\text{ }^{\circ}\text{C}$.

$V_{CE} = 20\text{ V}$
 $I_C = 1,2\text{ A}$ } regulated.

* Circuit consists of prematching circuit board in combination with complementary input and output slug tuners.

MICROWAVE LINEAR POWER TRANSISTOR

N-P-N transistor for use in a common-emitter class-A linear power amplifier up to 3 GHz.

Diffused emitter ballasting resistors, interdigitated structure, multicell geometry and gold sandwich metallization ensure an optimum temperature profile and excellent performance and reliability.

An input matching cell improves the input impedance and facilitates the design of wideband circuits.

QUICK REFERENCE DATA

R.F. performance up to $T_{mb} = 25\text{ }^{\circ}\text{C}$ in an unneutralized common-emitter class-A circuit

mode of operation	f GHz	V_{CE} V	I_C mA	P_{L1} mW	G_{po} dB	\bar{Z}_i Ω	\bar{Z}_L Ω
c.w.; linear amplifier	3	12	50	typ. 210	typ. 9,5	50 + j48	3 + j11

This data must be read in conjunction with GENERAL SAFETY RECOMMENDATIONS –
MICROWAVE SEMICONDUCTORS

MECHANICAL DATA

see page 2

POTENTIAL HAZARD—BERYLLIUM OXIDE

This device contains beryllium oxide, the dust of which is toxic. The device is entirely safe, provided that the beryllium oxide disc is not damaged. Care should be taken to ensure that all those who may handle, use or dispose of this device are aware of its nature and of the necessary safety precautions. In particular, it should never be thrown out with general industrial or domestic waste.



MECHANICAL DATA

Dimensions in mm

Fig. 1.

Emitter connected to flange.

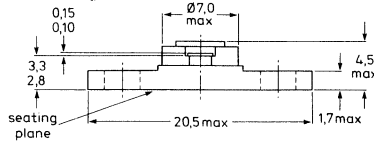

Torque on nut: max. 0,5 Nm

Recommended screw: M3

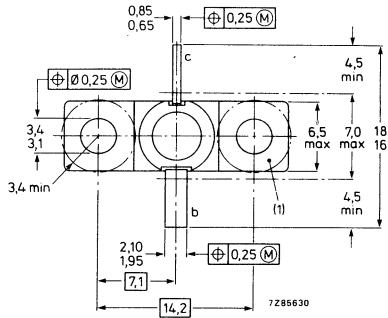

Marking code

RTC168 = LKE32001QC

(1) Flatness of this area ensures full thermal contact with bolt head.



RATINGS

Limiting values in accordance with the Absolute Maximum System (IEC 134)

Collector-base voltage (open emitter)	V_{CB0}	max.	45 V
Collector-emitter voltage ($R_{BE} = 220 \Omega$)	V_{CER}	max.	25 V
(open base)	V_{CEO}	max.	20 V
Emitter-base voltage (open collector)	V_{EBO}	max.	3,5 V
Collector current (d.c.)	I_C	max.	400 mA
Total power dissipation up to $T_{mb} = 75 \text{ }^\circ\text{C}$	P_{tot}	max.	1,5 W
Storage temperature	T_{stg}		-65 to +200 $^\circ\text{C}$
Junction temperature	T_j	max.	200 $^\circ\text{C}$
Lead soldering temperature at 0,3 mm from the case; $t_{sld} \leq 10 \text{ s}$	T_{sld}	max.	235 $^\circ\text{C}$

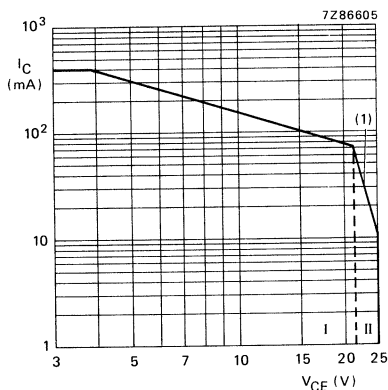

(1) Second breakdown limit (independent of temperature).

Fig. 2 D.C. SOAR at $T_{mb} \leq 75 \text{ }^\circ\text{C}$.

I Region of permissible d.c. operation.

II Permissible extension provided $R_{BE} \leq 220 \Omega$.

THERMAL RESISTANCE

From junction to mounting base

$R_{th \text{ j-mb}} = 45 \text{ }^\circ\text{C/W}$

From mounting base to heatsink

$R_{th \text{ mb-h}} = 0,7 \text{ }^\circ\text{C/W}$

CHARACTERISTICS

$T_{mb} = 25\text{ }^{\circ}\text{C}$

Collector-base breakdown voltage
open emitter; $I_C = 1\text{ mA}$

$V_{(BR)CBO} \geq 45\text{ V}$

Collector-emitter breakdown voltage
 $R_{BE} = 220\text{ }\Omega$; $I_C = 3\text{ mA}$
open base; $I_C = 3\text{ mA}$

$V_{(BR)CER} \geq 25\text{ V}$

$V_{(BR)CEO} \geq 20\text{ V}$

Emitter-base breakdown voltage
open collector; $I_E = 0,25\text{ mA}$

$V_{(BR)EBO} \geq 3,5\text{ V}$

Collector cut-off current
 $I_E = 0$; $V_{CB} = 20\text{ V}$

$I_{CBO} < 5\text{ }\mu\text{A}$

Emitter cut-off current
 $I_C = 0$; $V_{EB} = 1,5\text{ V}$

$I_{EBO} < 75\text{ nA}$

D.C. current gain
 $I_C = 50\text{ mA}$; $V_{CE} = 5\text{ V}$

$h_{FE} \quad 15\text{ to }150$

Collector-base capacitance at $f = 1\text{ MHz}$
 $I_E = I_C = 0$; $V_{CB} = 10\text{ V}$; $V_{EB} = 1,5\text{ V}$

$C_{cb} \quad \text{typ. } 1\text{ pF}$

Collector-emitter capacitance at $f = 1\text{ MHz}$
 $I_E = I_C = 0$; $V_{CE} = 10\text{ V}$; $V_{EB} = 1,5\text{ V}$

$C_{ce} \quad \text{typ. } 1,75\text{ pF}$

Emitter-base capacitance at $f = 1\text{ MHz}$
 $I_E = I_C = 0$; $V_{EB} = 1\text{ V}$; $V_{CB} = 10\text{ V}$

$C_{eb} \quad \text{typ. } 7\text{ pF}$

Forward power gain
 $V_{CE} = 12\text{ V}$; $I_C = 50\text{ mA}$; $f = 2\text{ GHz}$

$|s_{fe}|^2 \quad \text{typ. } 5,6\text{ dB}$

$V_{CE} = 12\text{ V}$; $I_C = 50\text{ mA}$; $f = 3\text{ GHz}$

$|s_{fe}|^2 \quad \text{typ. } 2,9\text{ dB}$

Maximum available power gain

$V_{CE} = 12\text{ V}$; $I_C = 50\text{ mA}$; $f = 2\text{ GHz}$

$G_{AM} \quad \text{typ. } 8\text{ dB}$



s-parameters (common-emitter)

$V_{CE} = 12\text{ V}$
 $I_C = 50\text{ mA}$ } regulated; $T_{mb} = 25\text{ }^\circ\text{C}$; $Z_0 = 50\text{ }\Omega$; typical values.

f GHz	s_{ie}	s_{re}	s_{fe}	s_{oe}
0,5	0,77/-170°	0,026(-31,8)/ 19°	5,30(14,5)/ 78°	0,33/ -76°
0,7	0,77/+178°	0,024(-32,4)/ 19°	3,92(11,9)/ 64°	0,32/ -82°
0,9	0,76/+172°	0,024(-32,4)/ 20°	3,12(9,9)/ 52°	0,34/ -88°
1,1	0,75/+166°	0,029(-30,8)/ 22°	2,65(8,5)/ 40°	0,37/ -92°
1,3	0,73/+160°	0,038(-28,5)/ 25°	2,37(7,5)/ 30°	0,41/ -99°
1,5	0,69/+153°	0,043(-27,4)/ 25°	2,15(6,7)/ 18°	0,44/-102°
1,7	0,65/+147°	0,052(-25,7)/ 26°	2,05(6,2)/ 6°	0,49/-107°
1,9	0,59/+139°	0,061(-24,3)/ 23°	1,95(5,8)/ -7°	0,54/-111°
2,0	0,54/+134°	0,066(-23,6)/ 21°	1,90(5,6)/ -12°	0,57/-111°
2,2	0,46/+127°	0,082(-21,7)/ 15°	1,84(5,3)/ -28°	0,63/-116°
2,4	0,34/+124°	0,097(-20,3)/ 6°	1,78(5,0)/ -43°	0,72/-122°
2,6	0,19/+130°	0,105(-19,6)/ -4°	1,70(4,6)/ -62°	0,80/-129°
2,8	0,11/-179°	0,102(-19,9)/ -18°	1,56(3,9)/ -80°	0,87/-136°
3,0	0,21/-157°	0,094(-20,6)/ -30°	1,40(2,9)/ -99°	0,91/-144°
3,2	0,35/-167°	0,083(-21,6)/ -45°	1,20(1,6)/ -118°	0,94/-153°
3,4	0,48/+143°	0,063(-24,0)/ -54°	0,99(-0,1)/ -135°	0,94/-162°

The figures given between brackets are values in dB.

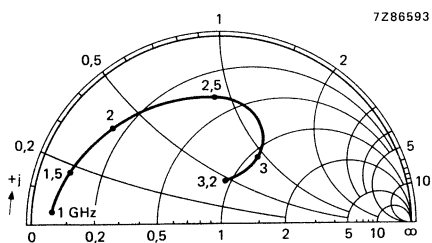

Fig. 3 Input impedance as a function of frequency for P_{L1} .

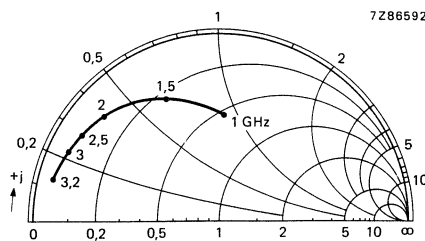

Fig. 4 Optimum load impedance as a function of frequency for P_{L1} .

Conditions for Figs 3 and 4:

$V_{CE} = 12\text{ V}$
 $I_C = 50\text{ mA}$ } regulated; typical values; $Z_0 = 50\text{ }\Omega$; $T_{mb} = 25\text{ }^\circ\text{C}$.

APPLICATION INFORMATION

R.F. performance in c.w. operation up to $T_{mb} = 25\text{ }^{\circ}\text{C}$ in an unneutralized common-emitter class-A circuit*

f GHz	V_{CE} (1) V	I_C (1) mA	P_{L1} (2) mW(dBm)	G_{p0} (3) dB	\bar{Z}_i Ω	\bar{Z}_L Ω
3	12	50	$\geq 90(19,5)$ typ. 210(23,2)	≥ 7 typ. 9,5	$50 + j48$	$3 + j11$

Notes

- V_{CE} and I_C regulated.
- Load power for 1 dB compressed power gain.
- Low-level power gain associated with P_{L1} .

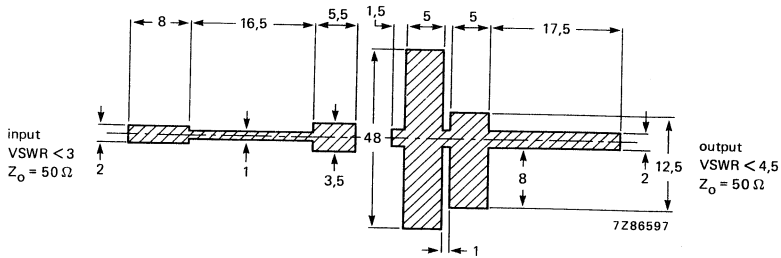

Fig. 5 Prematching test circuit board for 3 GHz. (Dimensions in mm.)

Striplines on a double Cu-clad printed-circuit board with PTFE fibre-glass dielectric ($\epsilon_r = 2,5$); thickness 0,8 mm.

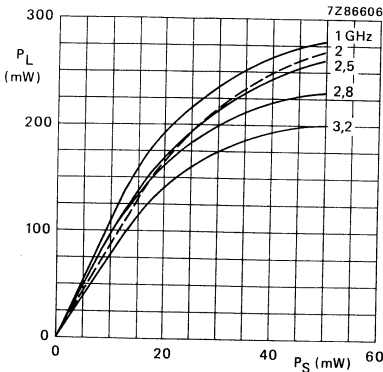

Fig. 6 Load power as a function of source power.

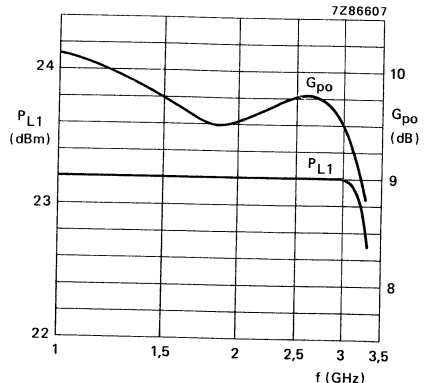

Fig. 7 Load power and power gain, associated with 1 dB compressed power gain, as a function of frequency.

Conditions for Figs 6 and 7:

$V_{CE} = 12\text{ V}$
 $I_C = 50\text{ mA}$ } regulated; typical values; $T_{mb} = 25\text{ }^{\circ}\text{C}$.

* Circuit consists of prematching circuit board in combination with complementary input and output slug tuners.

MICROWAVE LINEAR POWER TRANSISTORS

N-P-N transistors for use in a common-emitter class-A linear power amplifier up to 3 GHz.
Diffused emitter ballasting resistors, interdigitated structure, multicell geometry and gold sandwich metallization ensure an optimum temperature profile and excellent performance and reliability.
An input matching cell improves the input impedance and facilitates the design of wideband circuits.

QUICK REFERENCE DATA

R.F. performance up to $T_{mb} = 25\text{ }^{\circ}\text{C}$ in an unneutralized common-emitter class-A circuit

type no.	mode of operation	f GHz	V_{CE} V	I_C mA	P_{L1} mW	G_{po} dB	\bar{z}_i Ω	\bar{Z}_L Ω
LKE32002T	c.w.; linear amplifier	3	20	65	typ. 310	typ. 11,2	19 + j44	3,0 + j12
LKE32004T	c.w.; linear amplifier	3	20	130	typ. 710	typ. 11,0	7,5 + j22	2,5 + j5

This data must be read in conjunction with GENERAL SAFETY RECOMMENDATIONS –
MICROWAVE SEMICONDUCTORS

MECHANICAL DATA

see page 2

POTENTIAL HAZARD—BERYLLIUM OXIDE

This device contains beryllium oxide, the dust of which is toxic. The device is entirely safe, provided that the beryllium oxide disc is not damaged. Care should be taken to ensure that all those who may handle, use or dispose of this device are aware of its nature and of the necessary safety precautions. In particular, it should never be thrown out with general industrial or domestic waste.

MECHANICAL DATA

Fig. 1.

Emitter connected to flange.

Torque on nut: max. 0,5 Nm

Recommended screw: M3

Marking code

RTC114 = LKE32002T

RTC116 = LKE32004T

Dimensions in mm

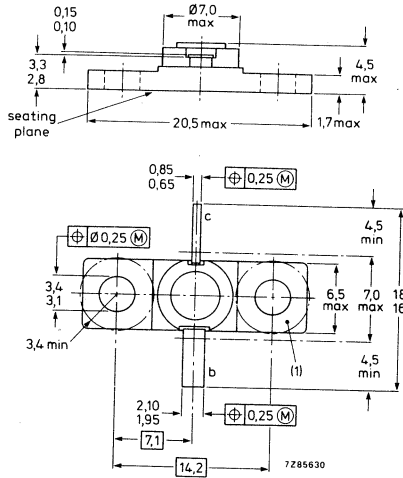

(1) Flatness of this area ensures full thermal contact with bolt head.



RATINGS

Limiting values in accordance with the Absolute Maximum System (IEC 134)

Collector-base voltage
(open emitter)

Collector-emitter voltage
 $R_{BE} = 220 \Omega$
(open base)

Emitter-base voltage
(open collector)

Collector current (d.c.)

Total power dissipation
up to $T_{mb} = 75 \text{ }^\circ\text{C}$

Storage temperature

Junction temperature

Lead soldering temperature
at 0,3 mm from the case; $t_{sld} = 10 \text{ s}$

	LKE32002T	LKE32004T	
V_{CBO}	max. 45	45	V
V_{CER}	max. 25	25	V
V_{CEO}	max. 20	20	V
V_{EBO}	max. 3,5	3,5	V
I_C	max. 400	800	mA
P_{tot}	max. 1,5	3	W
T_{stg}	-65 to +200		$^\circ\text{C}$
T_j	max.	200	$^\circ\text{C}$
T_{sld}	max.	235	$^\circ\text{C}$

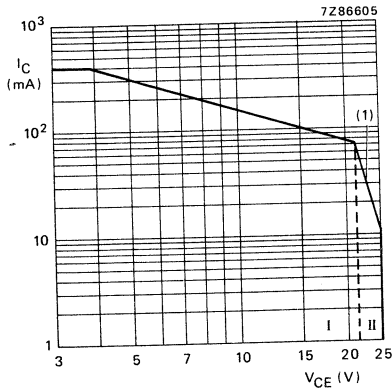

(1) Second breakdown limit (independent of temperature).

Fig. 2 D.C. SOAR LKE32002T at $T_{mb} \leq 75 \text{ }^\circ\text{C}$.

- I Region of permissible d.c. operation.
- II Permissible extension provided $R_{BE} \leq 220 \Omega$.

THERMAL RESISTANCE

From junction to mounting base

From mounting base to heatsink

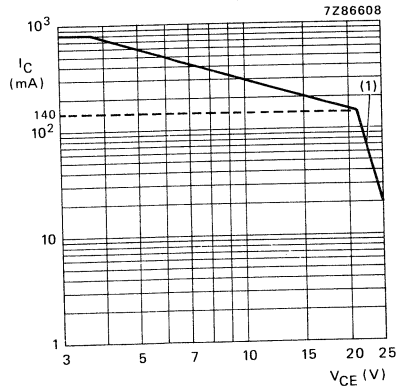

(1) Second breakdown limit (independent of temperature).

Fig. 3 D.C. SOAR LKE32004T at $T_{mb} \leq 75 \text{ }^\circ\text{C}$.

- I Region of permissible d.c. operation.
- II Permissible extension provided $R_{BE} \leq 220 \Omega$.

	LKE32002T	LKE32004T	
$R_{th j-mb}$	= 45	22	$^\circ\text{C/W}$
$R_{th mb-h}$	= 0,7	0,7	$^\circ\text{C/W}$

CHARACTERISTICS

$T_{mb} = 25\text{ }^{\circ}\text{C}$

	LKE32002T	LKE32004T
Collector-base breakdown voltage open emitter; $I_C = 1\text{ mA}$	$V_{(BR)CBO} > 45$	— V
open emitter; $I_C = 2\text{ mA}$	$V_{(BR)CBO} > —$	45 V
Collector-emitter breakdown voltage $R_{BE} = 220\ \Omega$; $I_C = 3\text{ mA}$	$V_{(BR)CER} > 25$	— V
$R_{BE} = 220\ \Omega$; $I_C = 5\text{ mA}$	$V_{(BR)CER} > —$	25 V
open base; $-I_E = 3\text{ mA}$	$V_{(BR)CEO} > 20$	— V
open base; $-I_E = 5\text{ mA}$	$V_{(BR)CEO} > —$	20 V
Emitter-base breakdown voltage open collector; $I_E = 250\ \mu\text{A}$	$V_{(BR)EBO} > 3,5$	— V
open collector; $I_E = 500\ \mu\text{A}$	$V_{(BR)EBO} > —$	3,5 V
Collector cut-off current $I_E = 0$; $V_{CB} = 20\text{ V}$	$I_{CBO} < 5$	10 μA
Emitter cut-off current $I_C = 0$; $V_{EB} = 1,5\text{ V}$	$I_{EBO} < 75$	150 nA
D.C. current gain $I_C = 65\text{ mA}$; $V_{CE} = 5\text{ V}$	$h_{FE} > 20$	—
	$h_{FE} < 200$	—
$I_C = 130\text{ mA}$; $V_{CE} = 5\text{ V}$	$h_{FE} > —$	20
	$h_{FE} < —$	200
Collector-base capacitance at $f = 1\text{ MHz}$ $I_E = I_C = 0$; $V_{CB} = 20\text{ V}$; $V_{EB} = 1,5\text{ V}$	C_{cb} typ. 0,85	1,8 pF
Collector-emitter capacitance at $f = 1\text{ MHz}$ $I_C = I_E = 0$; $V_{CE} = 20\text{ V}$; $V_{EB} = 1,5\text{ V}$	C_{ce} typ. 1,7	1,7 pF
Emitter-base capacitance at $f = 1\text{ MHz}$ $I_C = I_E = 0$; $V_{EB} = 1\text{ V}$; $V_{CB} = 10\text{ V}$	C_{eb} typ. 6,5	13 pF
Forward power gain $I_C = 65\text{ mA}$; $V_{CE} = 20\text{ V}$; $f = 3\text{ GHz}$	$ s_{fe} ^2$ typ. 2,9	— dB
$I_C = 130\text{ mA}$; $V_{CE} = 20\text{ V}$; $f = 3\text{ GHz}$	$ s_{fe} ^2$ typ. —	2,5 dB
Maximum available gain $I_C = 65\text{ mA}$; $V_{CE} = 20\text{ V}$; $f = 3\text{ GHz}$	GAM typ. 9	— dB
$I_C = 130\text{ mA}$; $V_{CE} = 20\text{ V}$; $f = 3\text{ GHz}$	GAM typ. —	12,5 dB

LKE32002T

s-parameters (common-emitter)

 $V_{CE} = 20 \text{ V}$
 $I_C = 65 \text{ mA}$
regulated; $T_{mb} = 25 \text{ }^\circ\text{C}$; $Z_o = 50 \text{ } \Omega$; typical values.

f GHz	S_{ie}	S_{re}	S_{fe}	S_{oe}
0,5	0,78/-174°	0,039(-28,1)/ 22°	5,16(14,3)/ 75°	0,36/ -65°
0,6	0,78/-179°	0,039(-28,1)/ 22°	4,36(12,8)/ 68°	0,36/ -69°
0,7	0,78/+ 177°	0,039(-28,1)/ 24°	3,81(11,6)/ 62°	0,37/ -73°
0,8	0,78/+ 173°	0,040(-28,0)/ 25°	3,40(10,6)/ 55°	0,38/ -77°
0,9	0,77/+ 170°	0,040(-27,8)/ 26°	3,04(9,7)/ 49°	0,39/ -81°
1,0	0,77/+ 166°	0,042(-27,4)/ 27°	2,75(8,8)/ 43°	0,40/ -84°
1,1	0,76/+ 163°	0,046(-26,7)/ 29°	2,56(8,2)/ 37°	0,42/ -88°
1,2	0,75/+ 160°	0,050(-26,1)/ 30°	2,39(7,6)/ 32°	0,43/ -92°
1,3	0,74/+ 157°	0,055(-25,2)/ 31°	2,25(7,0)/ 26°	0,45/ -96°
1,4	0,73/+ 154°	0,059(-24,6)/ 31°	2,12(6,5)/ 21°	0,47/ -99°
1,5	0,72/+ 150°	0,060(-24,4)/ 32°	2,01(6,1)/ 16°	0,48/-101°
1,6	0,71/+ 148°	0,066(-23,6)/ 34°	1,94(5,8)/ 10°	0,51/-104°
1,7	0,70/+ 144°	0,072(-22,9)/ 33°	1,88(5,5)/ 4°	0,53/-107°
1,8	0,69/+ 140°	0,077(-22,3)/ 31°	1,81(5,2)/ -2°	0,55/-110°
1,9	0,66/+ 136°	0,081(-21,8)/ 29°	1,75(4,8)/ -8°	0,56/-113°
2,0	0,63/+ 133°	0,087(-21,2)/ 29°	1,71(4,6)/ -13°	0,60/-115°
2,2	0,58/+ 125°	0,105(-19,6)/ 24°	1,65(4,3)/ -27°	0,64/-121°
2,4	0,50/+ 117°	0,122(-18,3)/ 16°	1,59(4,0)/ -39°	0,69/-127°
2,6	0,40/+ 108°	0,139(-17,1)/ 9°	1,54(3,7)/ -54°	0,75/-134°
2,8	0,27/ +97°	0,150(-16,5)/ -3°	1,47(3,3)/ -69°	0,82/-140°
3,0	0,13/ +88°	0,158(-16,0)/-13°	1,40(2,9)/ -86°	0,88/-147°
3,2	0,03/-165°	0,167(-15,5)/-27°	1,30(2,3)/-102°	0,93/-155°
3,4	0,19/-141°	0,162(-15,8)/-39°	1,16(1,3)/-121°	0,96/-165°
3,6	0,34/-148°	0,147(-16,6)/-53°	0,99(-0,0)/-138°	0,97/-174°
3,8	0,44/-158°	0,123(-18,2)/-62°	0,84(-1,6)/-153°	0,98/-179°
4,0	0,51/-168°	0,106(-19,5)/-72°	0,74(-2,6)/-167°	0,99/+ 174°
4,2	0,56/+ 179°	0,086(-21,3)/-80°	0,64(-3,9)/+ 178°	0,99/+ 168°
4,4	0,60/+ 167°	0,065(-23,7)/-87°	0,56(-5,1)/+ 162°	0,97/+ 161°
4,6	0,63/+ 156°	0,036(-28,9)/-89°	0,47(-6,5)/+ 146°	0,95/+ 154°

The figures given between brackets are values in dB.

LKE32004T

s-parameters (common-emitter)

$V_{CE} = 20 \text{ V}$
 $I_C = 130 \text{ mA}$ } regulated; $T_{mb} = 25 \text{ }^\circ\text{C}$; $Z_o = 50 \text{ } \Omega$; typical values.

f GHz	S _{ie}	S _{re}	S _{fe}	S _{oe}
0,5	0,88/-180°	0,007(-42,6)/ 20°	4,40(12,9)/ 74°	0,26/ -96°
0,7	0,87/+174°	0,006(-44,4)/ 24°	3,19(10,1)/ 61°	0,28/-102°
0,9	0,87/+171°	0,006(-43,8)/ 28°	2,51(8,0)/ 51°	0,32/-107°
1,1	0,86/+167°	0,011(-39,3)/ 31°	2,10(6,5)/ 41°	0,36/-112°
1,3	0,85/+164°	0,019(-34,7)/ 34°	1,86(5,4)/ 31°	0,41/-118°
1,5	0,83/+159°	0,022(-33,2)/ 35°	1,67(4,5)/ 22°	0,45/-121°
1,7	0,82/+155°	0,030(-30,6)/ 37°	1,58(4,0)/ 11°	0,49/-125°
1,9	0,78/+150°	0,034(-29,3)/ 34°	1,49(3,5)/ 0°	0,54/-128°
2,0	0,75/+146°	0,038(-28,4)/ 32°	1,46(3,3)/ -6°	0,56/-129°
2,2	0,71/+142°	0,050(-26,0)/ 28°	1,42(3,0)/ -18°	0,61/-134°
2,4	0,65/+139°	0,062(-24,1)/ 21°	1,40(3,0)/ -30°	0,66/-137°
2,6	0,55/+136°	0,074(-22,7)/ 13°	1,42(3,0)/ -46°	0,74/-141°
2,8	0,42/+136°	0,076(-22,7)/ 0°	1,37(2,8)/ -63°	0,81/-146°
3,0	0,31/+144°	0,073(-22,8)/-13°	1,33(2,5)/ -82°	0,87/-152°
3,2	0,31/+166°	0,068(-23,3)/-30°	1,20(1,6)/-103°	0,92/-161°
3,4	0,42/+178°	0,054(-25,3)/-43°	1,02(0,2)/-123°	0,94/-169°

The figures given between brackets are values in dB.



APPLICATION INFORMATION

R.F. performance in c.w. operation for the LKE32002T up to $T_{mb} = 25\text{ }^{\circ}\text{C}$ in an unneutralized common-emitter class-A circuit*

f GHz	V_{CE} (1) V	I_C (1) mA	P_{L1} (2) mW(dBm)	G_{po} (3) dB	\bar{z}_i Ω	\bar{Z}_L Ω
3	20	65	$\geq 200(23)$ typ. 310(25)	≥ 8 typ. 11,2	$19 + j44$	$3 + j12$

Notes

1. V_{CE} and I_C regulated.
2. Load power for 1 dB compressed power gain.
3. Low-level power gain associated with P_{L1} .

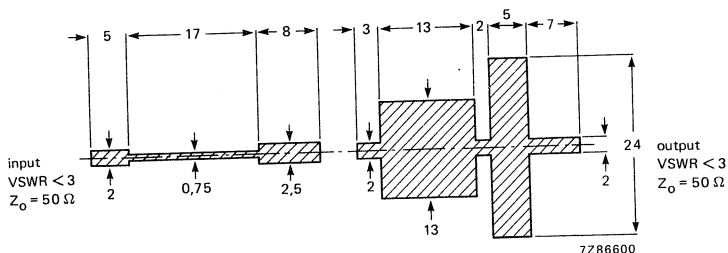

Fig. 4 Prematching test circuit board for 3 GHz. (Dimensions in mm.)

Striplines on a double Cu-clad printed-circuit board with PTFE fibre-glass dielectric ($\epsilon_r = 2,5$); thickness 0,8 mm.

* Circuit consists of prematching circuit board in combination with complementary input and output slug tuners.

LKE32002T

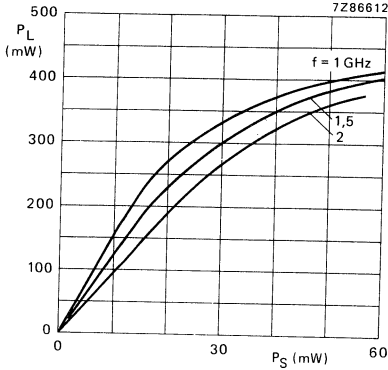

Fig. 5 Load power as a function of source power.

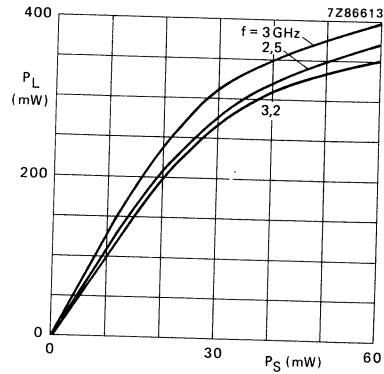

Fig. 6 Load power as a function of source power.

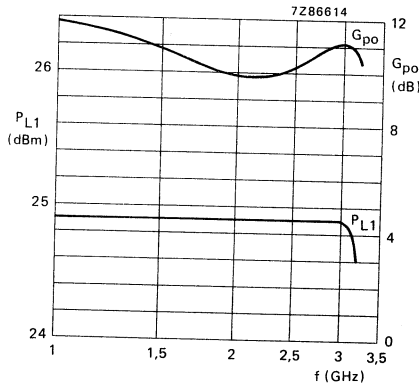

Fig. 7 Load power and power gain, associated with 1 dB compressed power gain, as a function of frequency.

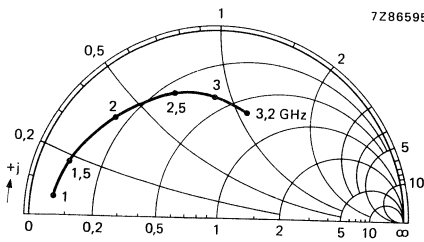

Fig. 8 Input impedance as a function of frequency for P_{L1} .

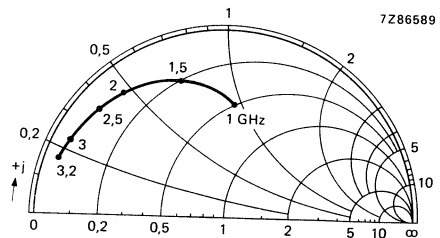

Fig. 9 Optimum load impedance as a function of frequency for P_{L1} .

Conditions for Figs 5 up to 9:

$V_{CE} = 20 \text{ V}$
 $I_C = 65 \text{ mA}$ } regulated; typical values; $Z_0 = 50 \Omega$; $T_{mb} = 25 \text{ }^\circ\text{C}$.

APPLICATION INFORMATION

R.F. performance in c.w. operation for the LKE32004T up to $T_{mb} = 25\text{ }^{\circ}\text{C}$ in an unneutralized common-emitter class-A circuit*

f GHz	V_{CE} (1) V	I_C (1) mA	P_{L1} (2) mW(dBm)	G_{po} (3) dB	\bar{z}_i Ω	\bar{z}_L Ω
3	20	130	$\geq 630(28)$ typ. 710(28,5)	≥ 8 typ. 11	$7,5 + j22$	$2,5 + j5$

Notes

1. V_{CE} and I_C regulated.
2. Load power for 1 dB compressed power gain.
3. Low-level power gain associated with P_{L1} .

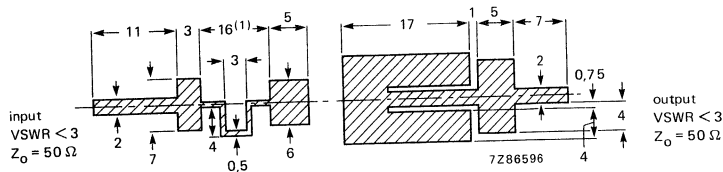

(1) Total path length.

Fig. 10 Prematching test circuit board for 3 GHz. (Dimensions in mm.)

Striplines on a double Cu-clad printed-circuit board with PTFE fibre-glass dielectric ($\epsilon_r = 2,5$); thickness 0,8 mm.

* Circuit consists of prematching circuit board in combination with complementary input and output slug tuners.

LKE32004T

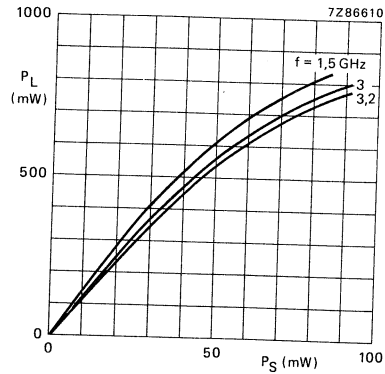
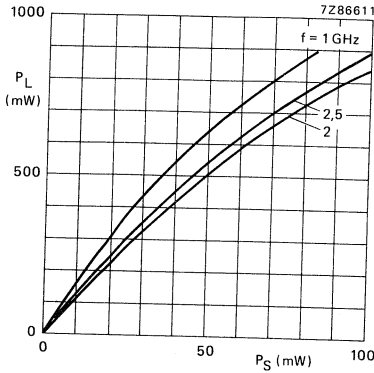

Fig. 11 Load power as a function of source power. Fig. 12 Load power as a function of source power.

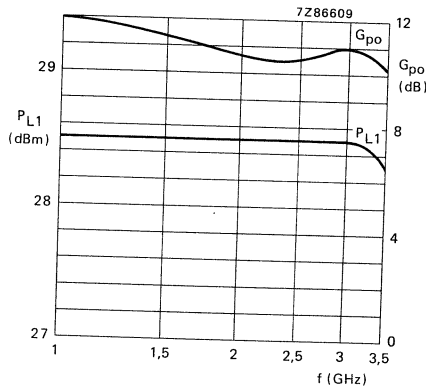

Fig. 13 Load power and power gain, associated with 1 dB compressed power gain, as a function of frequency.

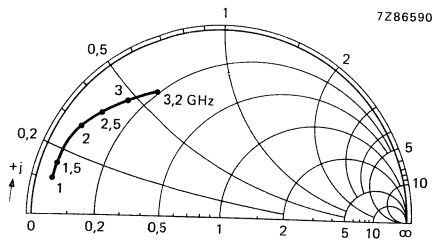

Fig. 14 Input impedance as a function of frequency for P_{L1} .

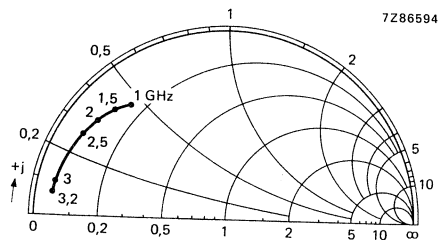

Fig. 15 Optimum load impedance as a function of frequency for P_{L1} .

Conditions for Figs 11 up to 15:

$V_{CE} = 20 \text{ V}$
 $I_C = 130 \text{ mA}$

regulated; typical values; $Z_0 = 50 \Omega$; $T_{mb} = 25 \text{ }^\circ\text{C}$.

MICROWAVE LINEAR POWER TRANSISTORS

N-P-N transistors for use in a common-emitter class-A linear power amplifier up to 4,2 GHz.
Diffused emitter ballasting resistors, self-aligned process entirely ion implanted and gold sandwich metallization ensure an optimum temperature profile and excellent performance and reliability.
An input matching cell improves the input impedance and facilitates the design of wideband circuits.

QUICK REFERENCE DATA

R.F. performance up to $T_{mb} = 25\text{ }^{\circ}\text{C}$ in an unneutralized common-emitter class-A circuit.

type no.	mode of operation	f GHz	V_{CE} V	I_C mA	P_{L1} mW	G_{po} dB	\bar{z}_i Ω	\bar{Z}_L Ω
LTE42005S	c.w. linear ampl.	4,2	18	110	typ. 550	typ. 7,2	100 + j40	4 + j4
LTE42008R	c.w. linear ampl.	4,2	16	250	typ. 940	typ. 7,5	17 + j12	3 - j9

MECHANICAL DATA

see page 2

This data must be read in conjunction with GENERAL SAFETY RECOMMENDATIONS—MICROWAVE SEMICONDUCTORS.

POTENTIAL HAZARD—BERYLLIUM OXIDE

This device contains beryllium oxide, the dust of which is toxic. The device is entirely safe, provided that the beryllium oxide disc is not damaged. Care should be taken to ensure that all those who may handle, use or dispose of this device are aware of its nature and of the necessary safety precautions. In particular, it should never be thrown out with general industrial or domestic waste.

LTE42005S
LTE42008R

MECHANICAL DATA

Fig. 1.

Emitter and metallic cap are connected to the seating plane.

Torque on nut: max. 0,4 Nm

Recommended screw: M2,5

Marking code

RTC502 = LTE42005S

RTC196 = LTE42008R

Dimensions in mm

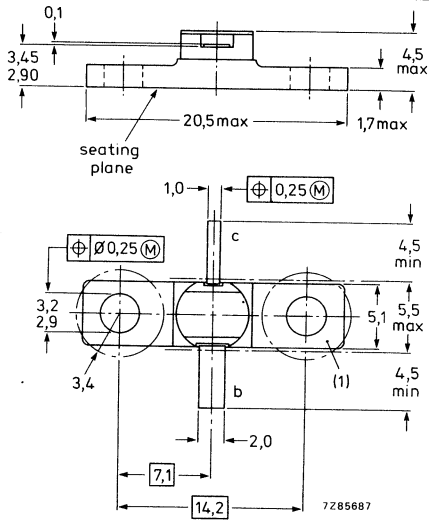

(1) Flatness of this area ensures full thermal contact with bolt head.

RATINGS

Limiting values in accordance with the Absolute Maximum System (IEC 134)

			LTE42005S	LTE42008R
Collector-base voltage (open emitter)	V_{CB0}	max.	40	40 V
Collector-emitter voltage $R_{BE} = 100 \Omega$ $R_{BE} = 250 \Omega$ (open base)	V_{CER}	max.	35	— V
	V_{CER}	max.	—	20 V
	V_{CEO}	max.	16	16 V
Emitter-base voltage (open collector)	V_{EBO}	max.	3	3,5 V
Collector current (d.c.)	I_C	max.	250	450 mA
Total power dissipation up to $T_{mb} = 75 \text{ }^\circ\text{C}$	P_{tot}	max.	4	6 W
Storage temperature	T_{stg}		—65 to +200	$^\circ\text{C}$
Junction temperature	T_j	max.	200	$^\circ\text{C}$
Lead soldering temperature at 0,3 mm from the case; $t_{sld} = 10 \text{ s}$	T_{sld}	max.	235	$^\circ\text{C}$

THERMAL RESISTANCE

			LTE42005S	LTE42008R
From junction to mounting base	$R_{th j-mb}$	=	36	12 $^\circ\text{C/W}$
From mounting base to heatsink	$R_{th mb-h}$	=	0,7	0,7 $^\circ\text{C/W}$



LTE42005S

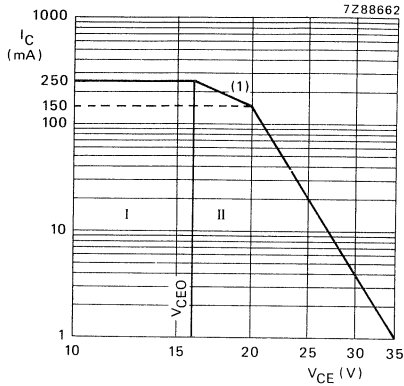

(1) Second breakdown limit
 (independent of temperature).

Fig. 2 D.C. SOAR at $T_{mb} \leq 75^\circ\text{C}$.

- I Region of permissible d.c. operation.
- II Permissible extension provided $R_{BE} \leq 100 \Omega$.

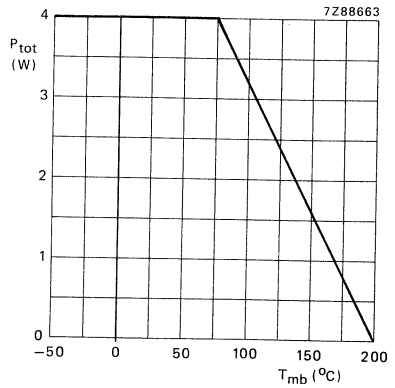
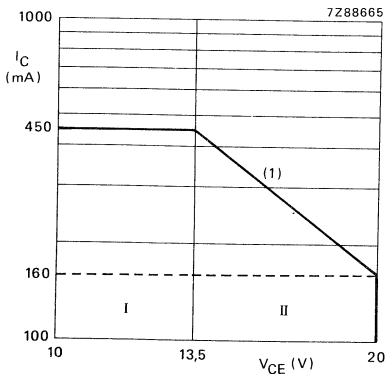

Fig. 3 Power derating curve vs. mounting base temperature.

LTE42008R



(1) Second breakdown limit
 (independent of temperature).

Fig. 4 D.C. SOAR at $T_{mb} \leq 75^\circ\text{C}$.

- I Region of permissible d.c. operation.
- II Permissible extension provided $R_{BE} \leq 250 \Omega$.

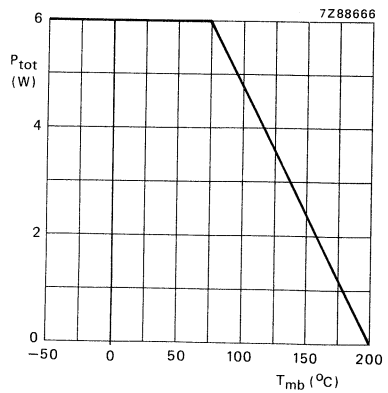

Fig. 5 Power derating curve vs. mounting base temperature.

CHARACTERISTICS

 $T_{mb} = 25\text{ }^{\circ}\text{C}$

Collector cut-off current

 $I_E = 0; V_{CB} = 20\text{ V}$ I_{CBO} < 0,1150 μA $I_E = 0; V_{CB} = 40\text{ V}$ I_{CBO} < 0,25

1 mA

Emitter cut-off current

 $I_C = 0; V_{EB} = 1,5\text{ V}$ I_{EBO} < 200

400 nA

 $I_C = 0; V_{EB} = 3,5\text{ V}$ I_{EBO} < 50200 μA

D.C. current gain

 $I_C = 110\text{ mA}; V_{CE} = 5\text{ V}$ h_{FE} > 15

-

h_{FE} < 150 $I_C = 250\text{ mA}; V_{CE} = 5\text{ V}$ h_{FE} > -

15

h_{FE} < -

150

Collector-base capacitance at $f = 1\text{ MHz}$ $I_E = I_C = 0; V_{CB} = 20\text{ V}; V_{EB} = 1,5\text{ V}$ C_{cb} typ. 0,5

- pF

 $I_E = I_C = 0; V_{CB} = 16\text{ V}; V_{EB} = 1,5\text{ V}$ C_{cb} typ. -

2 pF

Collector-emitter capacitance at $f = 1\text{ MHz}$ $I_C = I_E = 0; V_{CE} = 20\text{ V}; V_{EB} = 1,5\text{ V}$ C_{ce} typ. 1,5

- pF

 $I_C = I_E = 0; V_{CE} = 16\text{ V}; V_{EB} = 1,5\text{ V}$ C_{ce} typ. -

1,5 pF

Emitter-base capacitance at $f = 1\text{ MHz}$ $I_C = I_E = 0; V_{EB} = 1\text{ V}; V_{CB} = 10\text{ V}$ C_{eb} typ. 6,5

20 pF



LTE42005S

s-parameters (common-emitter)

$V_{CE} = 18\text{ V}$
 $I_C = 110\text{ mA}$ } regulated; $T_{mb} = 25\text{ }^\circ\text{C}$; $Z_o = 50\ \Omega$; typical values.

f GHz	S _{ie}	S _{re}	S _{fe}	S _{oe}
0,5	0,76/-176°	0,022(-33,2)/37°	8,13(18,2)/85°	0,35/-62°
0,6	0,75/+180°	0,023(-32,8)/37°	6,95(16,8)/78°	0,34/-66°
0,7	0,76/+177°	0,023(-32,8)/40°	5,95(15,5)/73°	0,34/-71°
0,8	0,76/+174°	0,024(-32,5)/41°	5,25(14,4)/67°	0,35/-75°
0,9	0,76/+171°	0,024(-32,3)/42°	4,69(13,4)/62°	0,35/-79°
1,0	0,75/+168°	0,026(-31,8)/43°	4,23(12,5)/57°	0,36/-83°
1,1	0,75/+165°	0,028(-31,0)/43°	3,88(11,8)/53°	0,37/-87°
1,2	0,74/+163°	0,031(-30,1)/43°	3,61(11,2)/49°	0,39/-90°
1,3	0,75/+160°	0,035(-29,2)/43°	3,36(10,5)/44°	0,40/-95°
1,4	0,74/+162°	0,037(-28,5)/44°	3,12(9,9)/41°	0,43/-98°
1,5	0,73/+157°	0,041(-27,8)/46°	2,95(9,4)/37°	0,43/-101°
1,6	0,73/+155°	0,045(-27,0)/46°	2,83(9,0)/32°	0,45/-104°
1,7	0,71/+154°	0,047(-26,5)/44°	2,70(8,6)/28°	0,47/-107°
1,8	0,70/+151°	0,049(-26,1)/43°	2,56(8,2)/23°	0,48/-110°
1,9	0,69/+148°	0,050(-25,9)/42°	2,44(7,7)/19°	0,50/-114°
2,0	0,68/+143°	0,051(-25,9)/39°	2,34(7,4)/ 14°	0,51/-116°
2,2	0,67/+138°	0,058(-24,7)/36°	2,16(6,7)/ 4°	0,55/-124°
2,4	0,65/+134°	0,067(-23,5)/34°	2,02(6,1)/ -2°	0,59/-129°
2,6	0,62/+129°	0,077(-22,3)/31°	1,95(5,8)/-12°	0,64/-134°
2,8	0,57/+122°	0,082(-21,7)/25°	1,84(5,3)/-21°	0,68/-138°
3,0	0,52/+113°	0,086(-21,3)/21°	1,78(5,0)/-32°	0,72/-143°
3,2	0,49/+104°	0,093(-20,6)/16°	1,67(4,5)/-42°	0,74/-150°
3,4	0,45/ +99°	0,102(-19,8)/13°	1,62(4,2)/-52°	0,80/-157°
3,6	0,38/ +92°	0,113(-18,9)/ 8°	1,52(3,6)/-64°	0,80/-163°
3,8	0,29/ +83°	0,119(-18,5)/ 6°	1,43(3,1)/-76°	0,82/-170°
4,0	0,24/+69°	0,137(-17,3)/ 2°	1,27(2,1)/ -88°	0,80/-179°
4,2	0,20/ +54°	0,165(-15,7)/ -5°	1,08(0,7)/ -98°	0,68/+171°
4,4	0,15/ +28°	0,202(-13,9)/-20°	0,92(-0,8)/-100°	0,51/+172°
4,6	0,12/ -36°	0,206(-13,7)/-38°	0,93(-0,6)/-102°	0,52/-174°
4,8	0,17/ -86°	0,195(-14,2)/-52°	0,97(-0,3)/-110°	0,63/-171°
5,0	0,24/-114°	0,177(-15,0)/-65°	0,97(-0,3)/-122°	0,73/-174°
5,2	0,31/-137°	0,164(-15,7)/-73°	0,93(-0,6)/-133°	0,79/-180°
5,4	0,41/-152°	0,154(-16,2)/-83°	0,88(-1,1)/-145°	0,83/+174°
5,6	0,48/-161°	0,134(-17,4)/-90°	0,81(-1,8)/-156°	0,85/+166°
5,8	0,53/-168°	0,122(-18,2)/-97°	0,77(-2,3)/-167°	0,87/+160°
6,0	0,56/-179°	0,105(-19,6)/-104°	0,70(-3,1)/-178°	0,89/+154°

The figures given between brackets are values in dB.

LTE42008R

s-parameters (common-emitter)

 $V_{CE} = 16 \text{ V}$
 $I_C = 250 \text{ mA}$ } regulated; $T_{mb} = 25 \text{ }^\circ\text{C}$; $Z_O = 50 \text{ } \Omega$; typical values.

f GHz	S_{ie}	S_{re}	S_{fe}	S_{oe}
0,5	0,91/175 $^\circ$	0,021(-33,6)/50 $^\circ$	4,25(12,6)/76 $^\circ$	0,42/-177 $^\circ$
0,6	0,91/173 $^\circ$	0,024(-32,5)/52 $^\circ$	3,59(11,1)/72 $^\circ$	0,42/-180 $^\circ$
0,7	0,91/171 $^\circ$	0,027(-31,4)/53 $^\circ$	3,11(9,9)/68 $^\circ$	0,42/+179 $^\circ$
0,8	0,90/169 $^\circ$	0,030(-30,4)/53 $^\circ$	2,75(8,8)/64 $^\circ$	0,42/+178 $^\circ$
0,9	0,90/167 $^\circ$	0,033(-34,7)/54 $^\circ$	2,45(7,8)/59 $^\circ$	0,42/+177 $^\circ$
1,0	0,89/165 $^\circ$	0,036(-28,8)/53 $^\circ$	2,21(6,9)/55 $^\circ$	0,42/+176 $^\circ$
1,1	0,88/163 $^\circ$	0,039(-28,1)/54 $^\circ$	2,02(6,1)/53 $^\circ$	0,43/+174 $^\circ$
1,2	0,88/162 $^\circ$	0,042(-27,4)/54 $^\circ$	1,88(5,5)/49 $^\circ$	0,43/+174 $^\circ$
1,3	0,88/160 $^\circ$	0,046(-26,8)/53 $^\circ$	1,75(4,9)/46 $^\circ$	0,43/+174 $^\circ$
1,4	0,89/159 $^\circ$	0,048(-26,3)/54 $^\circ$	1,64(4,3)/42 $^\circ$	0,43/+173 $^\circ$
1,5	0,89/158 $^\circ$	0,054(-25,4)/57 $^\circ$	1,55(3,9)/40 $^\circ$	0,43/+173 $^\circ$
1,6	0,89/157 $^\circ$	0,059(-24,6)/54 $^\circ$	1,52(3,7)/36 $^\circ$	0,43/+172 $^\circ$
1,7	0,89/155 $^\circ$	0,063(-24,0)/52 $^\circ$	1,47(3,3)/32 $^\circ$	0,43/+172 $^\circ$
1,8	0,88/153 $^\circ$	0,066(-23,6)/50 $^\circ$	1,40(2,9)/28 $^\circ$	0,44/+171 $^\circ$
2,0	0,88/151 $^\circ$	0,076(-22,4)/49 $^\circ$	1,30(2,3)/22 $^\circ$	0,44/+169 $^\circ$
2,2	0,87/147 $^\circ$	0,085(-21,4)/47 $^\circ$	1,23(1,8)/ 15 $^\circ$	0,46/+168 $^\circ$
2,4	0,87/144 $^\circ$	0,092(-20,7)/44 $^\circ$	1,16(1,3)/ 8 $^\circ$	0,47/+168 $^\circ$
2,6	0,86/142 $^\circ$	0,102(-19,8)/42 $^\circ$	1,15(1,2)/ 2 $^\circ$	0,49/+170 $^\circ$
2,8	0,85/139 $^\circ$	0,110(-19,2)/37 $^\circ$	1,11(0,9)/ -7 $^\circ$	0,49/+170 $^\circ$
3,0	0,83/135 $^\circ$	0,119(-18,5)/34 $^\circ$	1,12(1,0)/-15 $^\circ$	0,50/+169 $^\circ$
3,2	0,82/129 $^\circ$	0,125(-18,1)/29 $^\circ$	1,08(0,7)/-25 $^\circ$	0,54/+166 $^\circ$
3,4	0,81/126 $^\circ$	0,132(-17,6)/26 $^\circ$	1,08(0,7)/-33 $^\circ$	0,57/+165 $^\circ$
3,6	0,79/122 $^\circ$	0,138(-17,2)/21 $^\circ$	1,06(0,5)/-44 $^\circ$	0,62/+165 $^\circ$
3,8	0,76/120 $^\circ$	0,143(-16,9)/19 $^\circ$	1,08(0,6)/-55 $^\circ$	0,65/+165 $^\circ$
4,0	0,73/117 $^\circ$	0,148(-16,6)/13 $^\circ$	1,07(0,6)/-69 $^\circ$	0,70/+160 $^\circ$
4,2	0,69/115 $^\circ$	0,147(-16,7)/10 $^\circ$	1,04(0,4)/ -85 $^\circ$	0,76/+155 $^\circ$
4,4	0,67/112 $^\circ$	0,147(-16,6)/ 7 $^\circ$	1,00(0,0)/-104 $^\circ$	0,83/+149 $^\circ$
4,6	0,67/112 $^\circ$	0,140(-17,1)/ 6 $^\circ$	0,88(-1,1)/-122 $^\circ$	0,90/+142 $^\circ$
4,8	0,70/112 $^\circ$	0,147(-16,7)/ 9 $^\circ$	0,75(-2,5)/ -142 $^\circ$	0,93/+134 $^\circ$
5,0	0,72/114 $^\circ$	0,152(-16,3)/10 $^\circ$	0,59(-4,6)/-164 $^\circ$	0,92/+125 $^\circ$

The figures given between brackets are values in dB.

APPLICATION INFORMATION

R.F. performance in c.w. operation for the LTE42005S up to $T_{mb} = 25\text{ }^{\circ}\text{C}$ in an unneutralized common-emitter class-A circuit*

f GHz	V_{CE} (1) V	I_C (1) mA	P_{L1} (2) mW (dBm)	G_{po} (3) dB	\bar{Z}_i Ω	\bar{Z}_L Ω
4,2	18	110	$\geq 450(26,5)$ typ. 550(27,4)	$\geq 6,6$ typ. 7,2	$100 + j40$	$4 + j4$

Notes

1. V_{CE} and I_C regulated.
2. Load power for 1 dB compressed power gain.
3. Low-level power gain associated with P_{L1} .

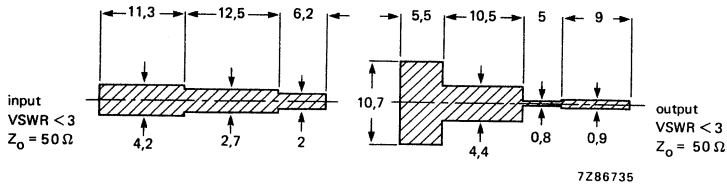

Fig. 6 Prematching test circuit board for 4,2 GHz. (Dimensions in mm.)

Input striplines on a double Cu-clad printed-circuit board with PTFE fibre-glass dielectric ($\epsilon_r = 2,54$); thickness 1,6 mm.

Output striplines on a double Cu=clad Rexolite printed-circuit board with dielectric ($\epsilon_r = 2,4$); thickness 0,25 mm.

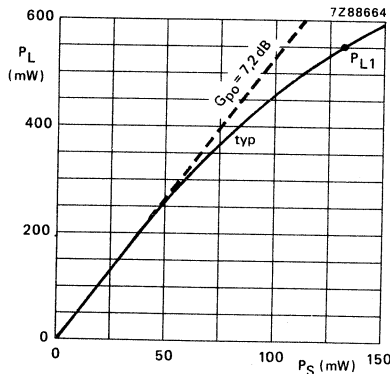

Fig. 7 Load power as a function of source power. $f = 4,2\ \text{GHz}$; $T_{mb} = 25\text{ }^{\circ}\text{C}$;
 $V_{CE} = 18\ \text{V}$
 $I_C = 110\ \text{mA}$ } regulated

* Circuit consists of prematching circuit boards in combination with complementary input and output slug tuners.

APPLICATION INFORMATION

R.F. performance in c.w. operation for the LTE42008R up to $T_{mb} = 25\text{ }^{\circ}\text{C}$ in an unneutralized common-emitter class-A circuit*.

f GHz	V_{CE} (1) V	I_C (1) mA	P_{L1} (2) mW (dBm)	G_{po} (3) dB	\bar{Z}_i Ω	\bar{Z}_L Ω
4,2	16	250	\geq 800(29) typ. 940(29,7)	\geq 7 typ. 7,5	17 + j12	3 - j9

Notes

1. V_{CE} and I_C regulated.
2. Load power for 1 dB compressed power gain.
3. Low-level power gain associated with P_{L1} .

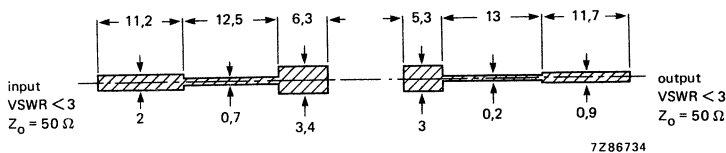

Fig. 8 Prematching test circuit board for 4,2 GHz. (Dimensions in mm.)

Input striplines on a double Cu-clad printed-circuit board with PTFE fibre-glass dielectric ($\epsilon_r = 2,54$); thickness 0,8 mm.
Output striplines on a double Cu-clad Rexolite printed-circuit board with dielectric ($\epsilon_r = 2,4$); thickness 0,25 mm.

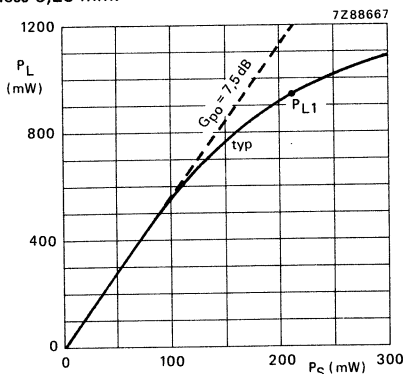

Fig. 9 Load power as a function of source power at 4,2 GHz.

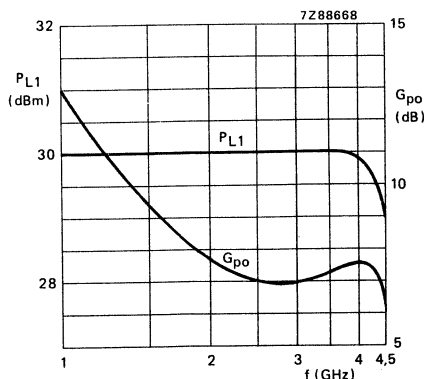

Fig. 10 Load power and power gain, associated with 1 dB compressed power gain, as a function of frequency.

Conditions for Figs 9 and 10:

$$\left. \begin{array}{l} V_{CE} = 16\text{ V} \\ I_C = 250\text{ mA} \end{array} \right\} \text{regulated; typical values; } T_{mb} = 25\text{ }^{\circ}\text{C}.$$

* Circuit consists of prematching circuit boards in combination with complementary input and output slug tuners.

LTE42008R

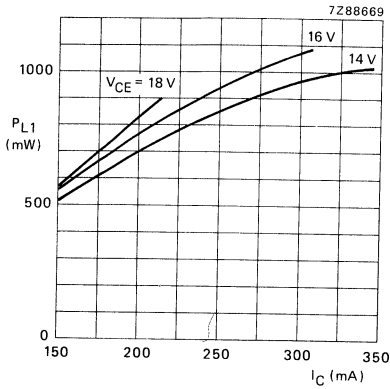

Fig. 11 Load power associated with 1 dB compressed power gain, as a function of collector current.

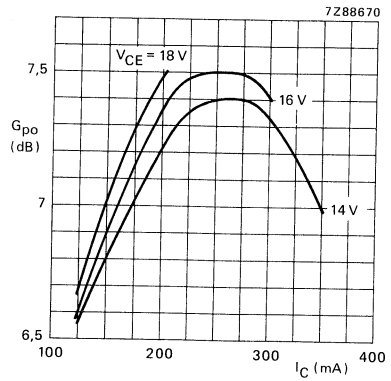

Fig. 12 Low-level power gain associated with P_{L1} as a function of collector current.

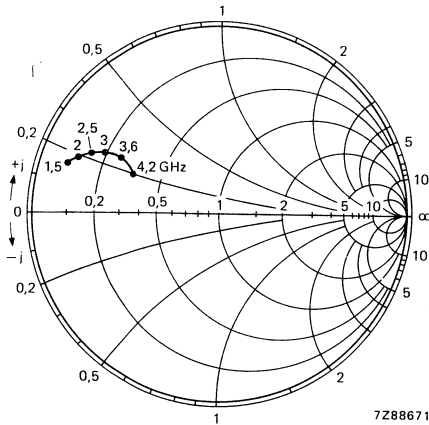

Fig. 14 Optimum load impedance as a function of frequency for P_{L1} .

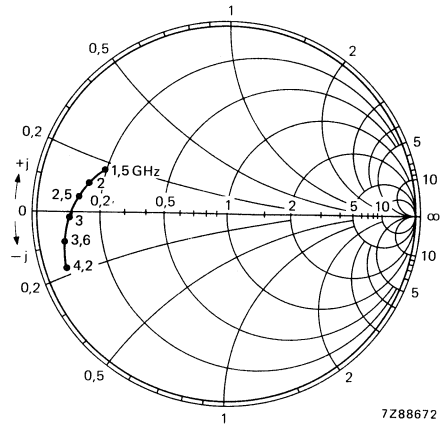

Fig. 13 Input impedance as a function of frequency for P_{L1} .

Conditions for Figs 11 and 12:

V_{CE} and I_C regulated; typical values; $T_{mb} = 25\text{ }^\circ\text{C}$.

Conditions for Figs 13 and 14:

$V_{CE} = 16\text{ V}$
 $I_C = 250\text{ mA}$ } regulated; typical values; $Z_O = 50\text{ }\Omega$; $T_{mb} = 25\text{ }^\circ\text{C}$.

MICROWAVE POWER TRANSISTORS

N-P-N silicon transistors for use in space, military and professional applications.

They offer the following technological advantages:

- Interdigitated structure: high emitter efficiency.
- Diffused emitter ballasting resistors providing excellent current sharing and withstanding a high VSWR.
- Gold metallization realizes very good stability of the characteristics and excellent lifetime.
- Multicell geometry gives good balance of dissipated power and low thermal resistance.

The PEE family has an envelope with stud to be mounted with a nut and the PDE family an envelope without stud to be soldered directly onto the heatsink.

Transistors are mounted in a common-emitter configuration in class-B but they also can operate in class-A or C.

QUICK REFERENCE DATA

R.F. performance up to $T_{mb} = 25\text{ }^{\circ}\text{C}$ in an unneutralized common-emitter class-B circuit

type number	mode of operation	f GHz	V _{CE} V	P _L W	G _p dB	η %
PEE1001U PDE1001U	c.w.	1	28	typ. 2	typ. 6,4	typ. 60
PEE1003U PDE1003U	c.w.	1	28	typ. 4,2	typ. 6,3	typ. 54
PEE1005U PDE1005U	c.w.	1	28	typ. 7,6	typ. 5,8	typ. 58
PEE1010U PDE1010U	c.w.	1	28	typ. 11	typ. 7,4	typ. 68

This data must be read in conjunction with GENERAL SAFETY RECOMMENDATIONS --
MICROWAVE SEMICONDUCTORS

MECHANICAL DATA

see page 2

POTENTIAL HAZARD—BERYLLIUM OXIDE

This device contains beryllium oxide, the dust of which is toxic. The device is entirely safe, provided that the beryllium oxide disc is not damaged. Care should be taken to ensure that all those who may handle, use or dispose of this device are aware of its nature and of the necessary safety precautions. In particular, it should never be thrown out with general industrial or domestic waste.

MECHANICAL DATA

Dimensions in mm

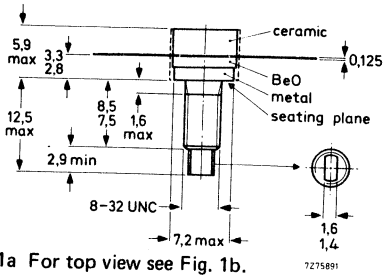
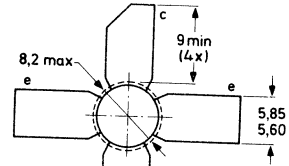
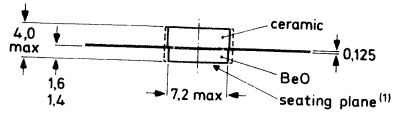

Fig. 1a For top view see Fig. 1b.

Torque on nut: min. 0,75 Nm
max. 0,85 Nm

Diameter of clearance hole in
heatsink: max. 4,2 mm.



(1) Metallized.

Fig. 1b.

7275892

RATINGS

Limiting values in accordance with the Absolute Maximum System (IEC 134)

		PEE/PDE1001U	1003U	1005U	1010U	
Collector-base voltage open emitter	V_{CBO}	max. 39	39	39	45	V
Collector-emitter voltage $R_{BE} = 10 \Omega$	V_{CER}	max. 39	39	39	45	V
Emitter-base voltage open collector	V_{EBO}	max. 3,5	3,5	3,5	3,5	V
Collector current (peak value)	I_{CM}	max. 250	450	900	1000	mA
Total power dissipation up to $T_{mb} = 25 \text{ }^\circ\text{C}$	P_{tot}	max. 5	7	12,5	20	W
Storage temperature	T_{stg}	-65 to +150				$^\circ\text{C}$
Operating junction temperature	T_j		max. 200			$^\circ\text{C}$
Lead soldering temperature at 0,7 mm from ceramic; $t_{sld} \leq 10 \text{ s}$	T_{sld}		max. 235			$^\circ\text{C}$

THERMAL RESISTANCE

From junction to mounting base

		PEE/PDE1001U	1003U	1005U	1010U	
$R_{th \text{ j-mb}}$	max.	25	18	10	6	$^\circ\text{C/W}$

CHARACTERISTICS

$T_{mb} = 25 \text{ }^\circ\text{C}$

Collector-base breakdown voltage open emitter; $I_C = 1 \text{ mA}$	$V_{(BR)CBO} >$	39				V
open emitter; $I_C = 2 \text{ mA}$	$V_{(BR)CBO} >$		39			V
open emitter; $I_C = 4 \text{ mA}$	$V_{(BR)CBO} >$			39		V
open emitter; $I_C = 10 \text{ mA}$	$V_{(BR)CBO} >$				45	V
Collector-emitter breakdown voltage $R_{BE} = 10 \Omega$; $I_C = 1 \text{ mA}$	$V_{(BR)CER} >$	39				V
$R_{BE} = 10 \Omega$; $I_C = 2 \text{ mA}$	$V_{(BR)CER} >$		39			V
$R_{BE} = 10 \Omega$; $I_C = 4 \text{ mA}$	$V_{(BR)CER} >$			39		V
$R_{BE} = 10 \Omega$; $I_C = 10 \text{ mA}$	$V_{(BR)CER} >$				45	V
Emitter-base breakdown voltage open collector; $I_E = 0,1 \text{ mA}$	$V_{(BR)EBO} >$	3,5				V
open collector; $I_E = 0,2 \text{ mA}$	$V_{(BR)EBO} >$		3,5			V
open collector; $I_E = 0,4 \text{ mA}$	$V_{(BR)EBO} >$			3,5		V
open collector; $I_E = 0,5 \text{ mA}$	$V_{(BR)EBO} >$				3,5	V
Collector cut-off current $I_E = 0$; $V_{CB} = 30 \text{ V}$	$I_{CBO} <$	50	100	200	1000	μA
Emitter cut-off current $I_C = 0$; $V_{EB} = 2 \text{ V}$	$I_{EBO} <$	50	100	200	1000	μA
Collector capacitance at $f = 1 \text{ MHz}$ $I_E = I_e = 0$; $V_{CB} = 30 \text{ V}$	$C_c <$	1,3	2	3,5	7	pF

PEE1001U PDE1001U FAMILIES

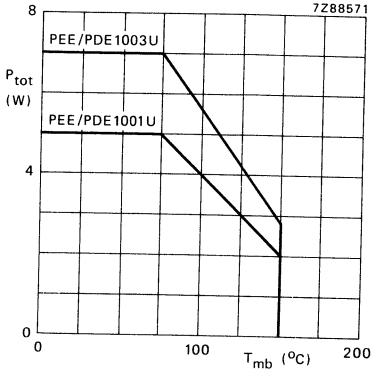

Fig. 2 Maximum permissible power dissipation as a function of mounting base temperature in class-B or C (c.w.).

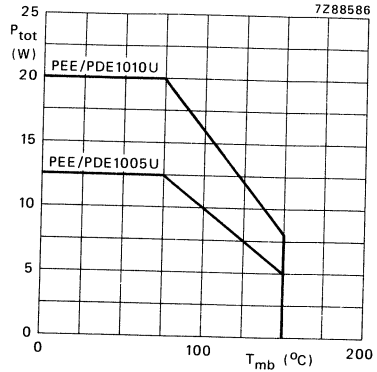

Fig. 3 Maximum permissible power dissipation as a function of mounting base temperature in class-B or C (c.w.).

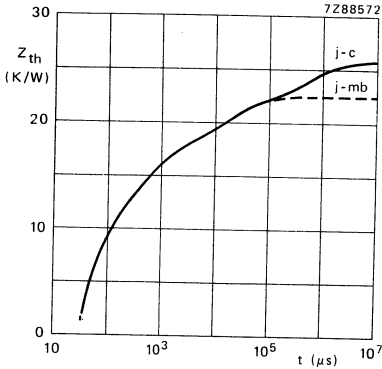

Fig. 4 Typ. transient thermal impedance as a function of time. PEE/PDE1001U

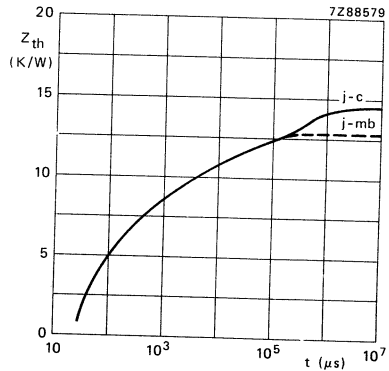

Fig. 5 Typ. transient thermal impedance as a function of time. PEE/PDE1003U

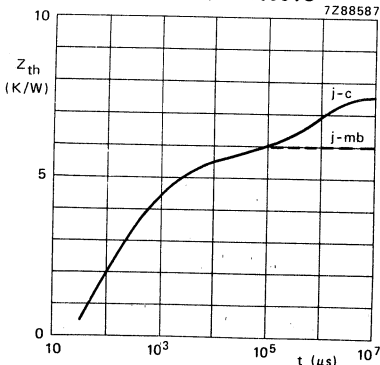

Fig. 6 Typ. transient thermal impedance as a function of time. PEE/PDE1005U

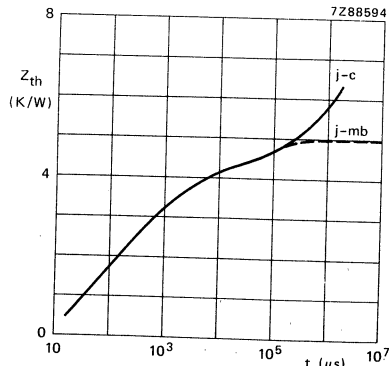
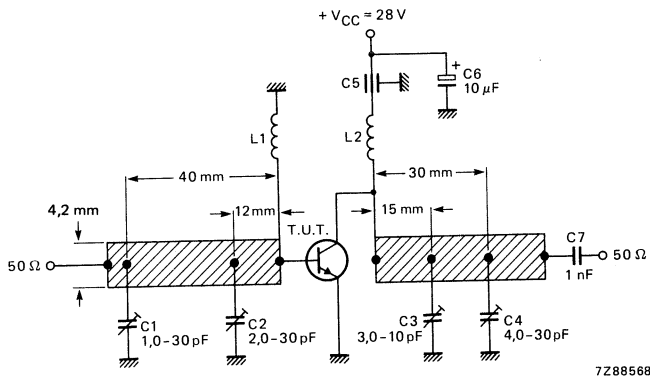

Fig. 7 Typ. transient thermal impedance as a function of time. PEE/PDE1010U

APPLICATION INFORMATION

R.F. performance in c.w. operation (common-emitter class-B circuit) up to $T_{mb} = 25\text{ }^{\circ}\text{C}$

type number	f GHz	V_{CE} V	P_L W	G_p dB	η %	\bar{Z}_i Ω	\bar{Z}_L Ω
PEE1001U PDE1001U	1	28	> 1,5 2	> 6 typ. 6,4	> 55 typ. 60	7,5 + j13	13 + j37
PEE1003U PDE1003U	1	28	> 3,7 4,2	> 5,9 typ. 6,3	> 49 typ. 54	5 + j15	10 + j20
PEE1005U PDE1005U	1	28	> 7 7,6	> 5,4 typ. 5,8	> 53 typ. 58	3 + j13	11 + j10



7288568

Fig. 8 1 GHz test circuit; c.w. class-B. T.U.T. = PEE/PDE1001U, PEE/PDE1003U and PEE/PDE1005U.

List of components:

- C5 = 500 pF feed-through capacitor
- C6 = 10 μF /40 V electrolytic capacitor
- C7 = 1 nF ceramic capacitor

L1 = L2 = 5 turns enamelled Cu wire (0,3 mm); int. dia. 4,0 mm; length 10,0 mm

Striplines on a double Cu-clad printed-circuit board with PTFE fibre-glass dielectric ($\epsilon_r = 2,74$); thickness 1/16 in.

APPLICATION INFORMATION

R.F. performance in c.w. operation (common-emitter class-B circuit) up to $T_{mb} = 25\text{ }^\circ\text{C}$

type number	f GHz	V _{CE} V	P _L W	G _p dB	η %	\bar{z}_i Ω	\bar{z}_L Ω
PEE1010U PDE1010U	1	28	> 9 11	> 6,5 typ. 7,4	> 60 typ. 68	2 + j1	7,5 + j18

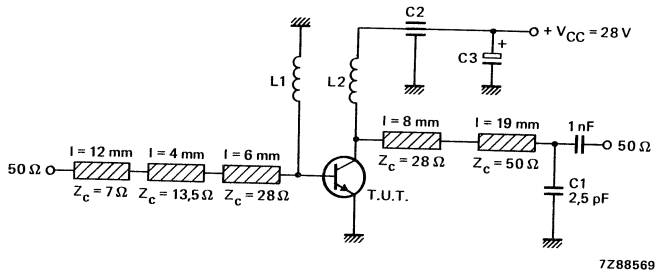

Fig. 9a 1 GHz test circuit; c.w. class-B. T.U.T. = PEE/PDE1010U.

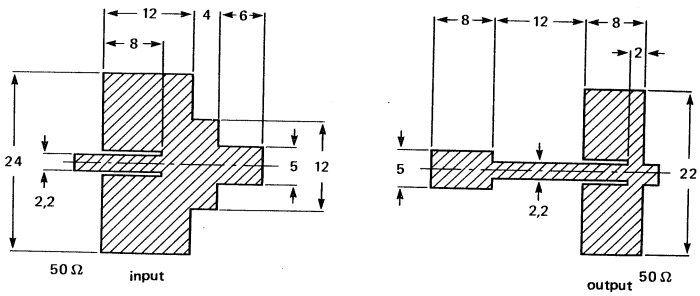

Fig. 9b Stripline dimensions.

List of components:

- C1 = 2,5 pF ceramic capacitor
- C2 = 500 pF feed-through capacitor
- C3 = 10 μF /40 V electrolytic capacitor

L1 = L2 = 5 turns enamelled Cu wire (0,3 mm); int. dia. 4,0 mm; length 10,0 mm

Striplines on a double Cu-clad printed-circuit board with PTFE fibre-glass dielectric ($\epsilon_r = 2,5$); thickness 1/32 in.

PEE1001U/PDE1001U

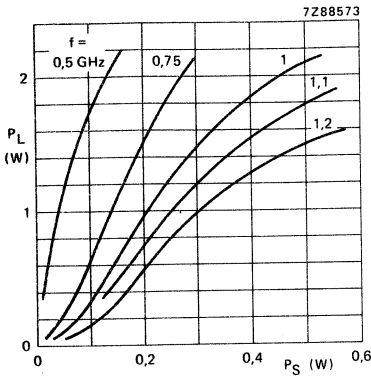

Fig. 10 Load power as a function of source power.

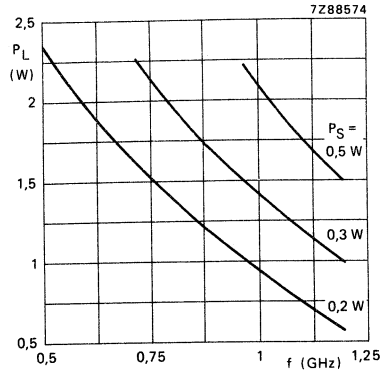

Fig. 11 Load power as a function of frequency.

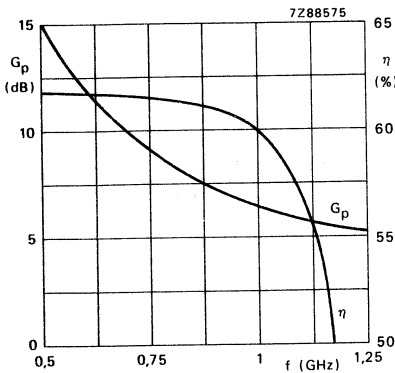

Fig. 12 Power gain and efficiency as a function of frequency.

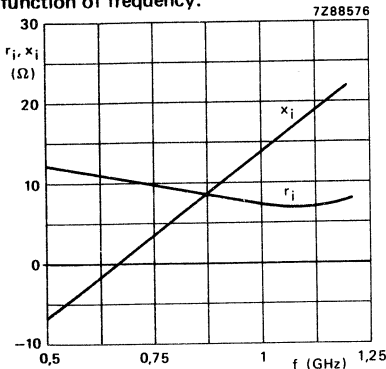

Fig. 13 Input impedance as a function of frequency. (See also Fig. 30).

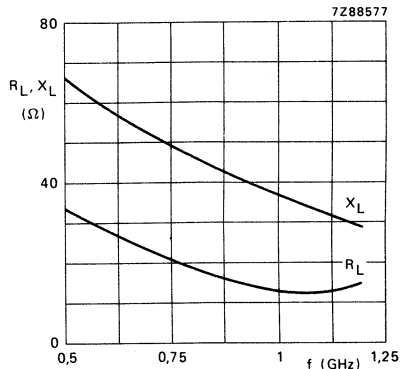

Fig. 14 Load impedance as a function of frequency. (See also Fig. 30).

Conditions for Figs 10 and 11:

$V_{CE} = 28 \text{ V}$; $T_{mb} = 25 \text{ }^\circ\text{C}$;
class-B operation; typical values.

Conditions for Figs 12, 13 and 14:

$V_{CE} = 28 \text{ V}$; $P_L = 1 \text{ W}$; $T_{mb} = 25 \text{ }^\circ\text{C}$;
class-B operation; typical values.



PEE1003U/PDE1003U

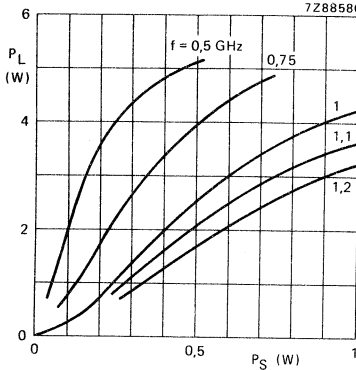

Fig. 15 Load power as a function of source power.

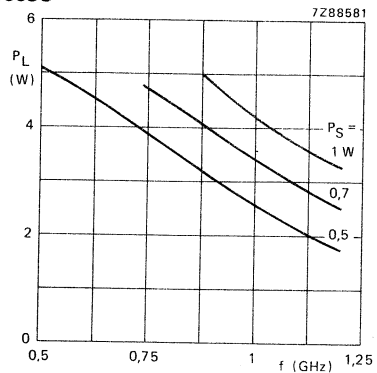

Fig. 16 Load power as a function of frequency.

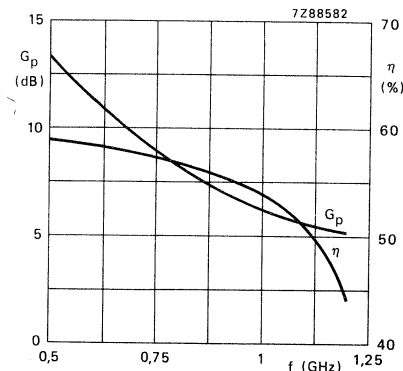

Fig. 17 Power gain and efficiency as a function of frequency.

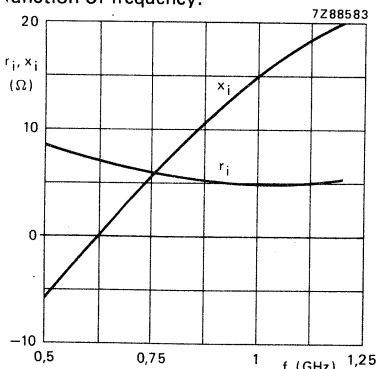

Fig. 18 Input impedance as a function of frequency. (See also Fig. 31).

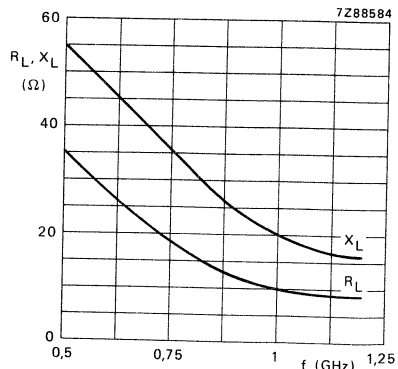

Fig. 19 Load impedance as a function of frequency. (See also Fig. 31).

Conditions for Figs 15 and 16:

$V_{CE} = 28 \text{ V}$; $T_{mb} = 25 \text{ }^\circ\text{C}$;
class-B operation; typical values.

Conditions for Figs 17, 18 and 19:

$V_{CE} = 28 \text{ V}$; $P_L = 3 \text{ W}$; $T_{mb} = 25 \text{ }^\circ\text{C}$;
class-B operation; typical values.

PEE1005U/PDE1005U

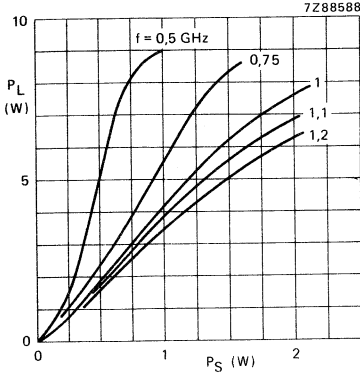

Fig. 20 Load power as a function of source power.

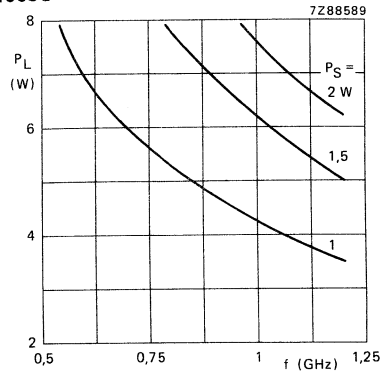

Fig. 21 Load power as a function of frequency.

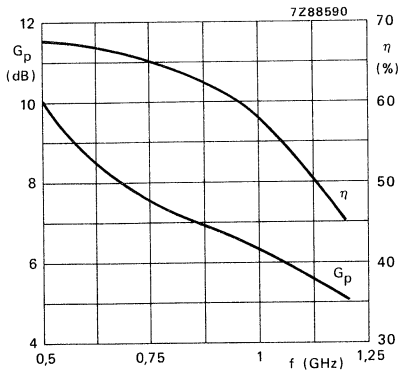

Fig. 22 Power gain and efficiency as a function of frequency.

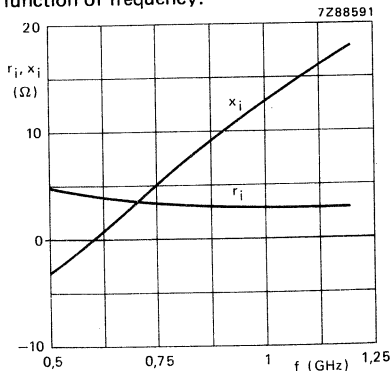

Fig. 23 Input impedance as a function of frequency. (See also Fig. 32).

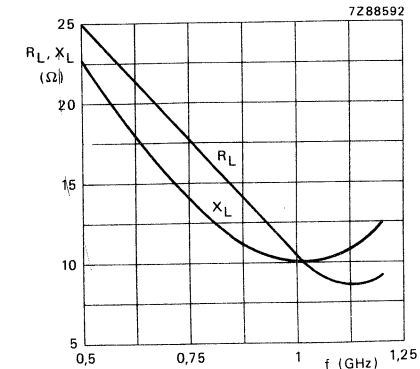

Fig. 24 Load impedance as a function of frequency. (See also Fig. 32).

Conditions for Figs 20 and 21:

$V_{CE} = 28 \text{ V}$; $T_{mb} = 25 \text{ }^\circ\text{C}$;
class-B operation; typical values.

Conditions for Figs 22, 23 and 24:

$V_{CE} = 28 \text{ V}$; $P_L = 5 \text{ W}$; $T_{mb} = 25 \text{ }^\circ\text{C}$;
class-B operation; typical values.



PEE1010U/PDE1010U

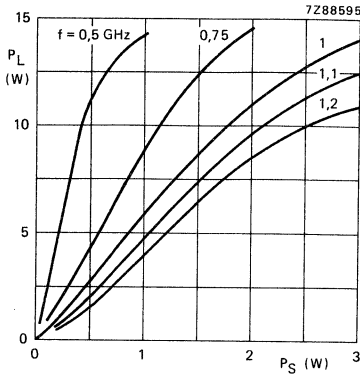

Fig. 25 Load power as a function of source power.

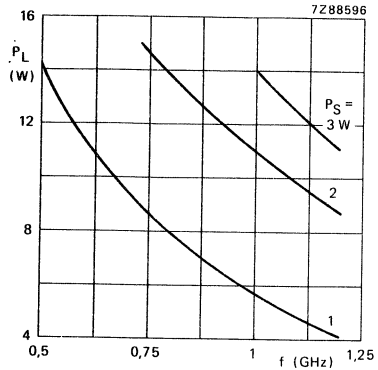

Fig. 26 Load power as a function of frequency.

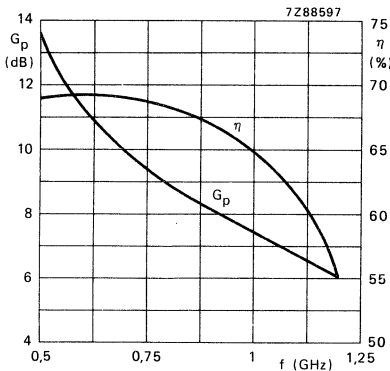

Fig. 27 Power gain and efficiency as a function of frequency.

Conditions for Figs 25 and 26:

$V_{CE} = 28$ V; $T_{mb} = 25$ °C;

class-B operation; typical values.

Conditions for Figs 27, 28 and 29:

$V_{CE} = 28$ V; $P_L = 10$ W; $T_{mb} = 25$ °C;

class-B operation; typical values.

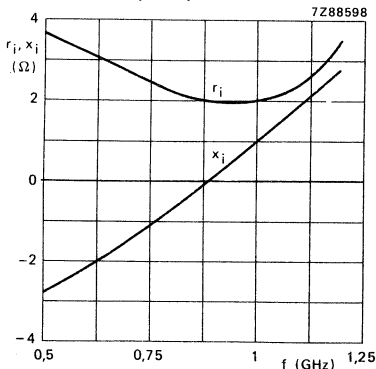

Fig. 28 Input impedance as a function of frequency. (See also Fig. 33).

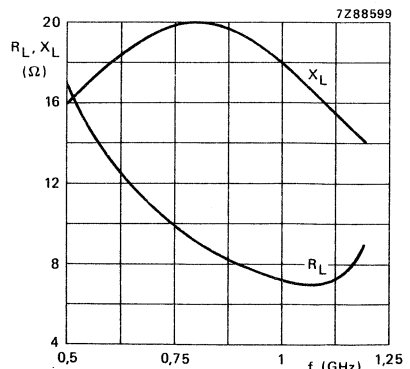
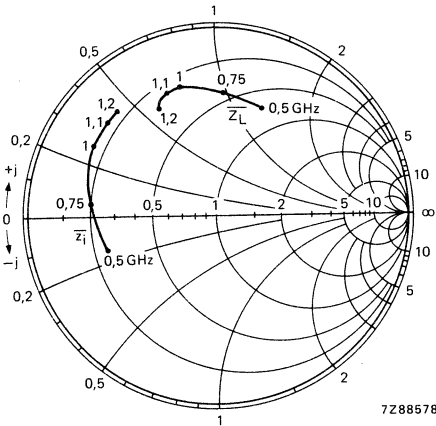
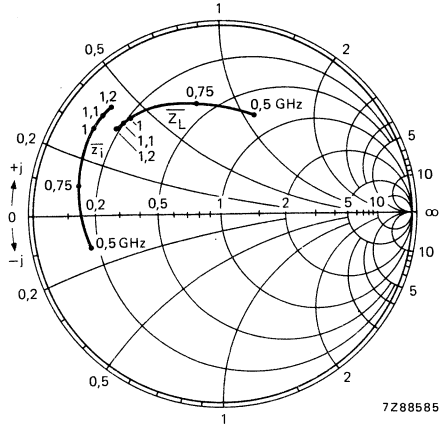

Fig. 29 Load impedance as a function of frequency. (See also Fig. 33).



7288578

Fig. 30 Input and load impedance of PEE1001U/PDE1001U at $P_L = 1$ W.



7288585

Fig. 31 Input and load impedance of PEE1003U/PDE1003U at $P_L = 3$ W.

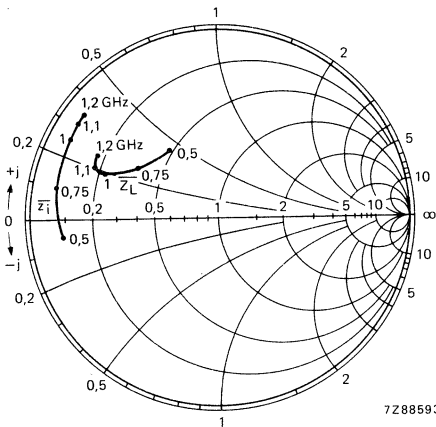

7288593

Fig. 32 Input and load impedance of PEE1005U/PDE1005U at $P_L = 5$ W.

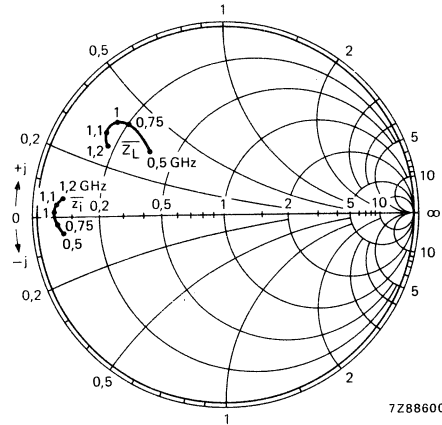

7288600

Fig. 33 Input and load impedance of PEE1010U/PDE1010U at $P_L = 10$ W.

Conditions for Figs 30 to 33:

$V_{CE} = 28$ V; $T_{mb} = 25$ °C; class-B operation; typical values.

MICROWAVE POWER TRANSISTOR

N-P-N silicon transistor for use in space, military and professional applications.

It offers the following technological advantages:

- Interdigitated structure: high emitter efficiency.
- Diffused emitter ballasting resistors providing excellent current sharing and withstanding a high VSWR.
- Gold metallization realizes very good stability of the characteristics and excellent lifetime.
- Multicell geometry gives good balance of dissipated power and low thermal resistance.

QUICK REFERENCE DATA

R.F. performance up to $T_{mb} = 25\text{ }^{\circ}\text{C}$ in an unneutralized common-base class-C circuit

mode of operation	f GHz	V_{CE} V	P_L W	G_p dB	η %	\bar{z}_i Ω	\bar{Z}_L Ω
c.w.	1	28	typ. 25	typ. 11	typ. 58	$2 + j6,5$	$5 + j1$
c.w.	2	28	typ. 10	typ. 6	typ. 42	$7 + j6,75$	$1,5 - j7$

MECHANICAL DATA

see page 2

This data must be read in conjunction with GENERAL SAFETY RECOMMENDATIONS—MICROWAVE SEMICONDUCTORS.

POTENTIAL HAZARD—BERYLLIUM OXIDE

This device contains beryllium oxide, the dust of which is toxic. The device is entirely safe, provided that the beryllium oxide disc is not damaged. Care should be taken to ensure that all those who may handle, use or dispose of this device are aware of its nature and of the necessary safety precautions. In particular, it should never be thrown out with general industrial or domestic waste.

MECHANICAL DATA

Fig. 1.

Base connected to flange

Torque on nut: max. 0,5 Nm

Recommended screw: M3

Marking code

RTC2010M = PKB20010U

(1) Flatness of this area ensures full thermal contact with bolt head.

Dimensions in mm

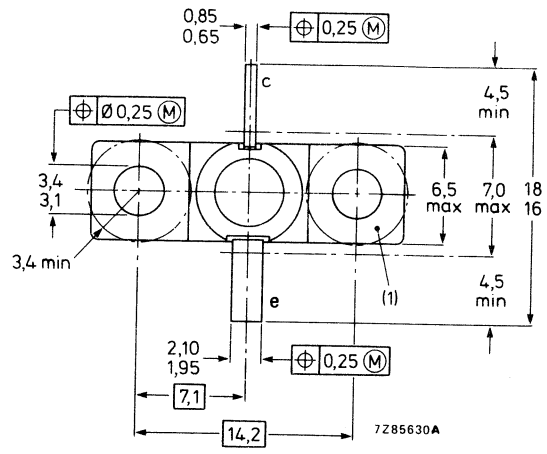
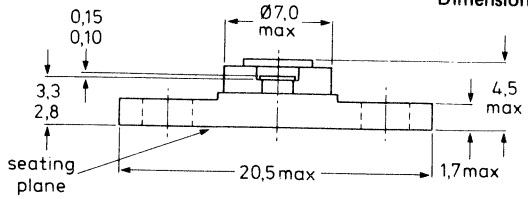

RATINGS

Limiting values in accordance with the Absolute Maximum System (IEC 134)

Collector-base voltage (open emitter)	V_{CB0}	max.	40 V
Collector-emitter voltage ($R_{BE} \leq 10 \Omega$)	V_{CER}	max.	40 V
(open base)	V_{CEO}	max.	22 V
Emitter-base voltage (open collector)	V_{EBO}	max.	3 V
Collector current (d.c.)	I_C	max.	2 A
Total power dissipation up to $T_{mb} = 75 \text{ }^\circ\text{C}$	P_{tot}	max.	25 W
Storage temperature	T_{stg}		-65 to +200 $^\circ\text{C}$
Junction temperature	T_j	max.	200 $^\circ\text{C}$
Lead soldering temperature at 0,3 mm from the case; $t_{sld} \leq 10 \text{ s}$	T_{sld}	max.	235 $^\circ\text{C}$

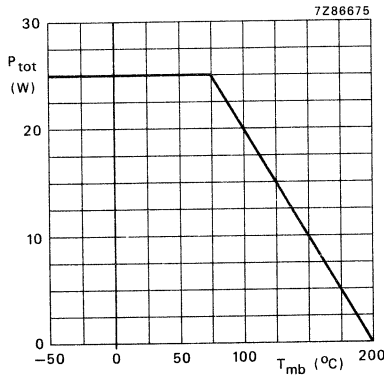

Fig. 2 Maximum permissible total power dissipation as a function of mounting base temperature.

THERMAL RESISTANCE

From junction to mounting base
From mounting base to heatsink

$R_{th \text{ j-mb}}$	=	4 $^\circ\text{C/W}$
$R_{th \text{ mb-h}}$	=	0,7 $^\circ\text{C/W}$

CHARACTERISTICS

$T_{mb} = 25\text{ }^{\circ}\text{C}$

Collector-base breakdown voltage
open emitter; $I_C = 20\text{ mA}$

$V_{(BR)CBO} \geq 40\text{ V}$

Collector-emitter breakdown voltage
 $R_{BE} = 10\text{ }\Omega$; $I_C = 40\text{ mA}$

$V_{(BR)CER} \geq 40\text{ V}$

Emitter-base breakdown voltage
open collector; $I_E = 1\text{ mA}$

$V_{(BR)EBO} \geq 3\text{ V}$

Collector cut-off current
 $I_E = 0$; $V_{CB} = 30\text{ V}$

$I_{CBO} < 100\text{ }\mu\text{A}$

Emitter cut-off current
 $I_C = 0$; $V_{EB} = 1,5\text{ V}$

$I_{EBO} < 1,2\text{ }\mu\text{A}$

Collector-base capacitance at $f = 1\text{ MHz}$
 $I_E = I_C = 0$; $V_{CB} = 28\text{ V}$; $V_{EB} = 1,5\text{ V}$

C_{cb} typ. 10 pF

Collector-emitter capacitance at $f = 1\text{ MHz}$
 $I_E = I_C = 0$; $V_{CE} = 28\text{ V}$; $V_{EB} = 1,5\text{ V}$

C_{ce} typ. 4 pF

Emitter-base capacitance at $f = 1\text{ MHz}$
 $I_E = I_C = 0$; $V_{EB} = 1\text{ V}$; $V_{CB} = 15\text{ V}$

C_{eb} typ. 100 pF



APPLICATION INFORMATION

R.F. performance in c.w. operation up to $T_{mb} = 25\text{ }^{\circ}\text{C}$ in an unneutralized common-base class-C circuit*

f GHz	V_{CE} V	P_L W	G_p dB	η %	\bar{z}_i Ω	\bar{z}_L Ω
1	28	> 20 typ. 25	> 10 typ. 11	typ. 58	$2 + j6,5$	$5 + j1$
2	28	> 8 typ. 10	> 5 typ. 6	typ. 42	$7 + j6,75$	$1,5 - j7$

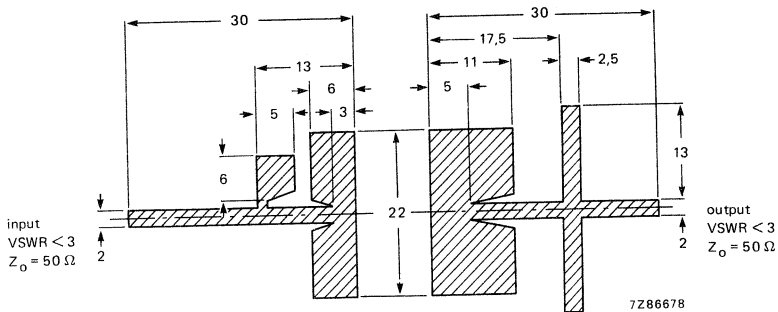

Fig. 3 Prematching test circuit board for 2 GHz. (Dimensions in mm.)

Striplines on a double Cu-clad printed-circuit board with PTFE fibre-glass dielectric ($\epsilon_r = 2,55$); thickness 0,8 mm.

* Circuit consists of prematching circuit board in combination with complementary input and output slug tuners.

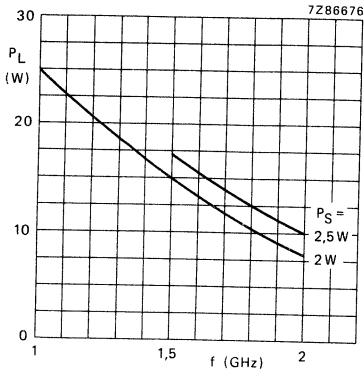

Fig. 4 Load power as a function of frequency.

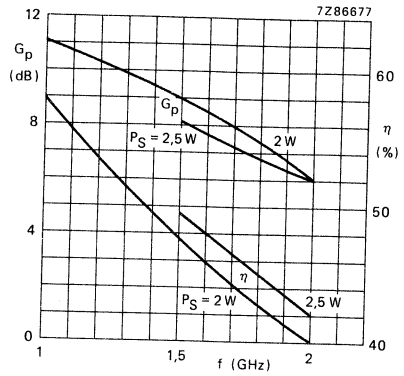

Fig. 5 Power gain and efficiency as a function of frequency.

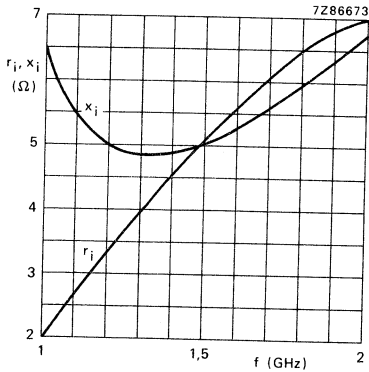

Fig. 6 Input impedance as a function of frequency.

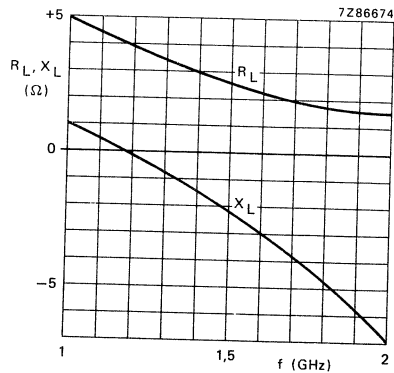

Fig. 7 Load impedance as a function of frequency.

Conditions for Figs 4 and 5:

$V_{CE} = 28$ V; $T_{mb} = 25$ °C; typical values.

Conditions for Figs 6 and 7:

$V_{CE} = 28$ V; $T_{mb} = 25$ °C; $Z_0 = 50$ Ω ; typical values.

MICROWAVE POWER TRANSISTORS

N-P-N silicon transistors for use in common-base class-B power amplifiers up to 3 GHz.

Diffused emitter ballasting resistors, interdigitated structure, multicell geometry and gold sandwich metallization ensure an optimum temperature profile and excellent performance and reliability.

QUICK REFERENCE DATA

R.F. performance up to $T_{mb} = 25\text{ }^{\circ}\text{C}$ in an unneutralized common-base class-B circuit

type number	mode of operation	f GHz	V_{CE} V	P_L W	G_p dB	η %	\bar{z}_i Ω	\bar{z}_L Ω
PKB32001U	c.w.	3	28	typ. 1,3	typ. 8,1	typ. 34	$11 + j1,8$	$3 + j3,5$
PKB32003U	c.w.	3	28	typ. 3,2	typ. 6,3	typ. 33	$14 - j4$	$2,5 - j1$
PKB32005U	c.w.	3	28	typ. 5	typ. 5,2	typ. 31	$13 + j2$	$2 - j4$

MECHANICAL DATA

see page 2

This data must be read in conjunction with GENERAL SAFETY RECOMMENDATIONS—MICROWAVE SEMICONDUCTORS.

POTENTIAL HAZARD—BERYLLIUM OXIDE

This device contains beryllium oxide, the dust of which is toxic. The device is entirely safe, provided that the beryllium oxide disc is not damaged. Care should be taken to ensure that all those who may handle, use or dispose of this device are aware of its nature and of the necessary safety precautions. In particular, it should never be thrown out with general industrial or domestic waste.



MECHANICAL DATA

Fig. 1.

Base connected to flange

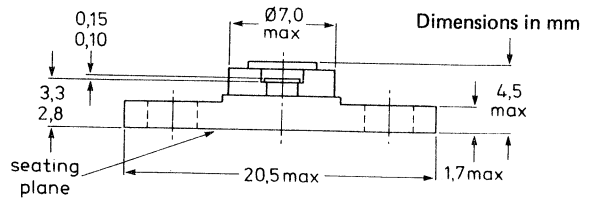

Torque on nut: max. 0,5 Nm

Recommended screw: M3

Marking code

RTC3001M = PKB32001U

RTC3003M = PKB32003U

RTC3005M = PKB32005U

(1) Flatness of this area ensures full thermal contact with bolt head.

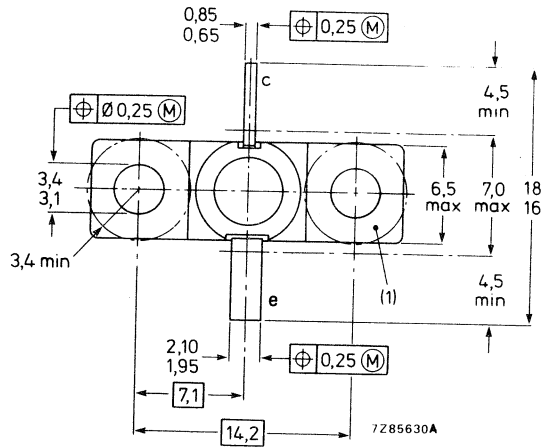

RATINGS

Limiting values in accordance with the Absolute Maximum System (IEC 134)

		PKB32001U	32003U	32005U	
Collector-base voltage open emitter	V_{CBO}	max. 45	45	45	V
Collector-emitter voltage $R_{BE} = 10 \Omega$	V_{CER}	max. 45	45	45	V
Emitter-base voltage open collector	V_{EBO}	max. 3	3	3	V
Collector current (d.c.)	I_C	max. 0,4	0,8	2	A
R.F. power dissipation ($f > 1$ MHz) up to $T_{mb} = 75^\circ C$	P_{rf}	max. 4,5	9	15	W
Storage temperature	T_{stg}	max. -65 to +200			$^\circ C$
Junction temperature	T_j	max.	200		$^\circ C$
Lead soldering temperature at 0,3 mm from ceramic; $t_{sld} \leq 10$ s	T_{sld}	max.	235		$^\circ C$

THERMAL RESISTANCE

From junction to mounting base	$R_{th j-mb}$	max. 22	11	6,6	K/W
From mounting base to heatsink	$R_{th mb-h}$	max. 0,7	0,7	0,7	K/W

CHARACTERISTICS

		PKB32001U	32003U	32005U	
Collector-base breakdown voltage open emitter; $I_C = 1$ mA	$V(BR)CBO$	≥ 45	—	—	V
open emitter; $I_C = 3$ mA	$V(BR)CBO$	\geq —	45	—	V
open emitter; $I_C = 5$ mA	$V(BR)CBO$	\geq —	—	45	V
Collector-emitter breakdown voltage $R_{BE} = 10 \Omega$; $I_C = 5$ mA	$V(BR)CER$	≥ 45	—	—	V
$R_{BE} = 10 \Omega$; $I_C = 15$ mA	$V(BR)CER$	\geq —	45	—	V
$R_{BE} = 10 \Omega$; $I_C = 25$ mA	$V(BR)CER$	\geq —	—	45	V
Emitter-base breakdown voltage open collector; $I_E = 1$ mA	$V(BR)EBO$	≥ 3	3	3	V
Collector cut-off current $I_E = 0$; $V_{CB} = 28$ V	I_{CBO}	≤ 100	300	500	μA
Emitter cut-off current $I_C = 0$; $V_{EB} = 1,5$ V	I_{EBO}	≤ 150	500	750	nA
Collector-base capacitance at $f = 1$ MHz $I_E = I_C = 0$; $V_{CB} = 28$ V; $V_{EB} = 1,5$ V	C_{cb}	typ. 2	4,5	6,2	pF
Collector-emitter capacitance at $f = 1$ MHz $I_E = I_C = 0$; $V_{CB} = 28$ V; $V_{EB} = 1,5$ V	C_{ce}	typ. 0,8	1,6	2,6	pF
Emitter-base capacitance at $f = 1$ MHz $I_E = I_C = 0$; $V_{EB} = 1$ V; $V_{CB} = 10$ V	C_{eb}	typ. —	26	—	pF
$I_E = I_C = 0$; $V_{EB} = 1$ V; $V_{CB} = 28$ V	C_{eb}	typ. 12	—	43	pF



PKB32001U

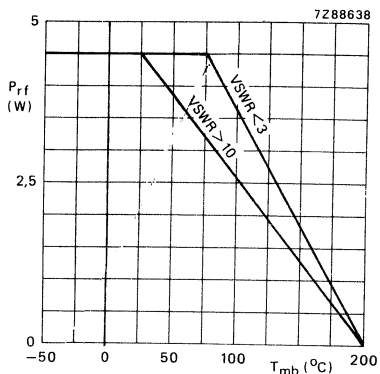

Fig. 2 Maximum permissible r.f. power dissipation as a function of mounting base temperature.

PKB32003U

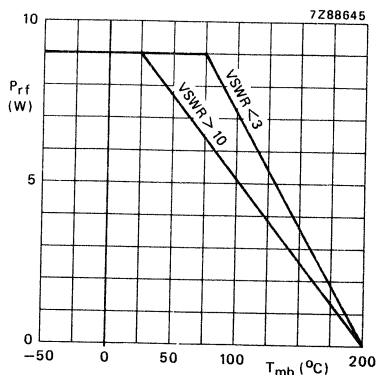

Fig. 3 Maximum permissible r.f. power dissipation as a function of mounting base temperature.

PKB32005U

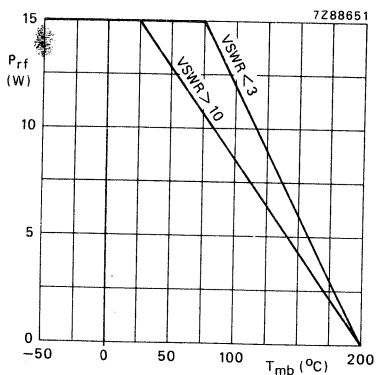

Fig. 4 Maximum permissible r.f. power dissipation as a function of mounting base temperature.

Conditions for Figs 2, 3 and 4:

$V_{CB} \leq 30 \text{ V}$; $f > 1 \text{ MHz}$.

APPLICATION INFORMATION

R.F. performance up to $T_{mb} = 25\text{ }^\circ\text{C}$ in an unneutralized common-base class-B circuit*

type number	mode of operation	f GHz	V_{CE} V	P_L W	G_p dB	η %	\bar{Z}_i Ω	\bar{Z}_L Ω
PKB32001U	c.w.	3	28	> 1 typ. 1,3	> 7 typ. 8,1	> 30 typ. 34	$11 + j1,8$	$3 + j3,5$
PKB32003U	c.w.	3	28	> 2,4 typ. 3,2	> 5,7 typ. 6,3	> 30 typ. 33	$14 - j4$	$2,5 - j1$
PKB32005U	c.w.	3	28	> 4,5 typ. 5	> 4,8 typ. 5,2	> 28 typ. 31	$13 + j2$	$2 - j4$

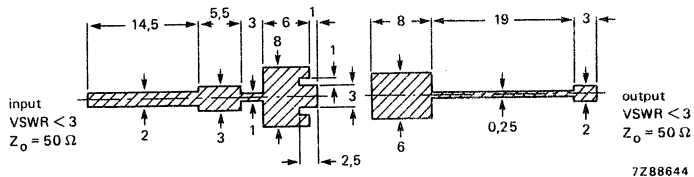

Fig. 5 Prematching test circuit boards for the PKB32003U at 3 GHz. (Dimensions in mm.)

Input striplines on a double Cu-clad printed-circuit board with PTFE fibre-glass dielectric ($\epsilon_r = 2,54$); thickness 0,8 mm.

Output striplines on a double Cu-clad Rexolite printed-circuit board with dielectric ($\epsilon_r = 2,4$); thickness 0,25 mm.

* Circuit consists of prematching circuit board in combination with complementary input and output slug tuners.

PKB32001U

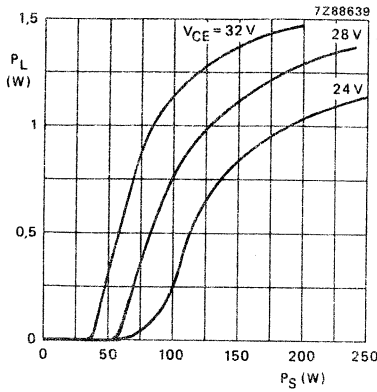

Fig. 6 Load power at $f = 3$ GHz as a function of source power with collector-emitter voltage as parameter.

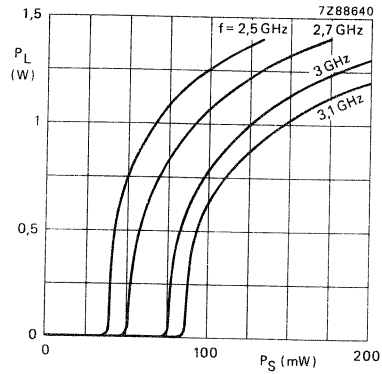

Fig. 7 Load power at $V_{CE} = 28$ V as a function of source power with frequency as parameter.

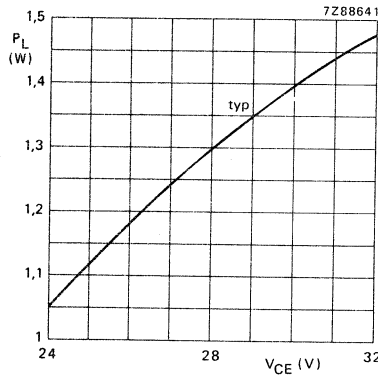

Fig. 8 Load power at $f = 3$ GHz and $P_S = 0,2$ W as a function of collector-emitter voltage.

Conditions for Figs 6, 7 and 8:
 Class-B operation; $T_{mb} = 25$ °C; typical values.



PKB32003U

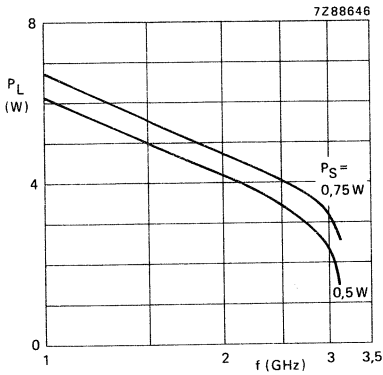

Fig. 9 Load power as a function of frequency with source power as parameter.

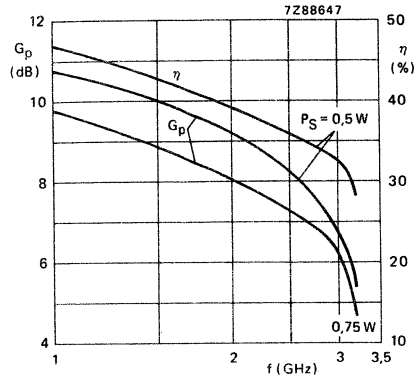

Fig. 10 Power gain and efficiency as a function of frequency with source power as parameter.

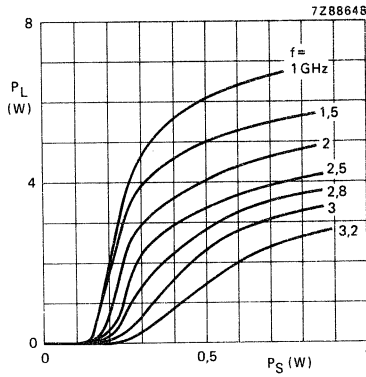

Fig. 11 Load power as a function of source power with frequency as parameter.

Conditions for Figs 9, 10 and 11:

Class-B operation; $V_{CE} = 28$ V; $T_{mb} = 25$ °C; typical values.

PKB32005U

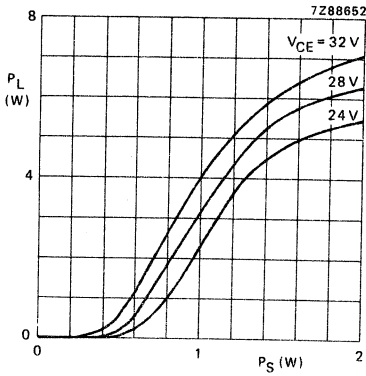

Fig. 12 Load power at $f = 3$ GHz as a function of source power with collector-emitter voltage as parameter.

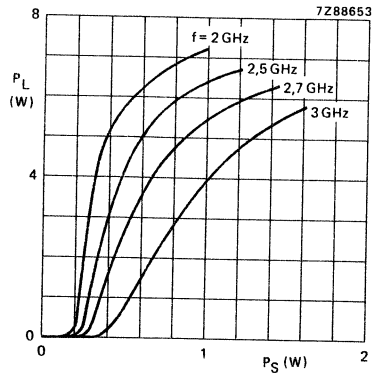

Fig. 13 Load power at $V_{CE} = 28$ V as a function of source power with frequency as parameter.

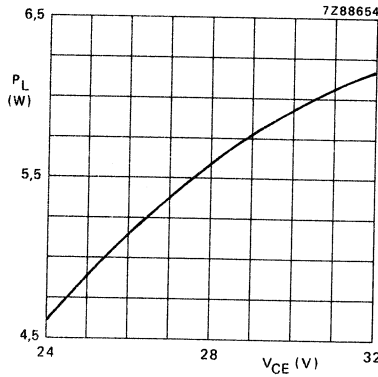

Fig. 14 Load power at $f = 3$ GHz and $P_S = 1,5$ W as a function of collector-emitter voltage.

Conditions for Figs 12, 13 and 14:
 Class-B operation; $T_{mb} = 25$ °C; typical values.

PKB32001U

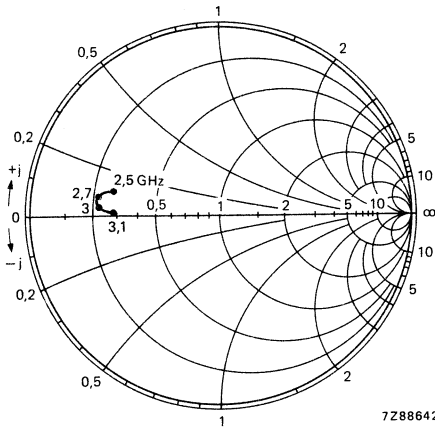

Fig. 15 Input impedance as a function of frequency.

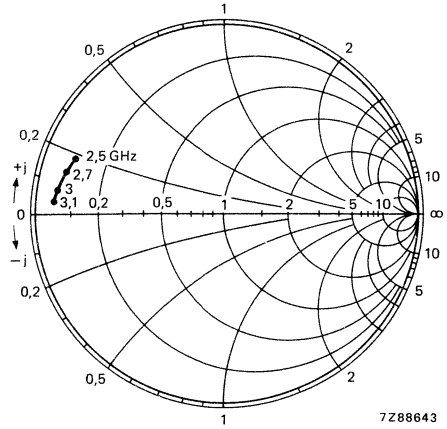

Fig. 16 Optimum load impedance as a function of frequency.

Conditions for Figs 15 and 16:

$V_{CE} = 28 \text{ V}$; class-B operation; $T_{mb} = 25 \text{ }^\circ\text{C}$; $Z_o = 50 \text{ } \Omega$; typical values.

PKB32003U

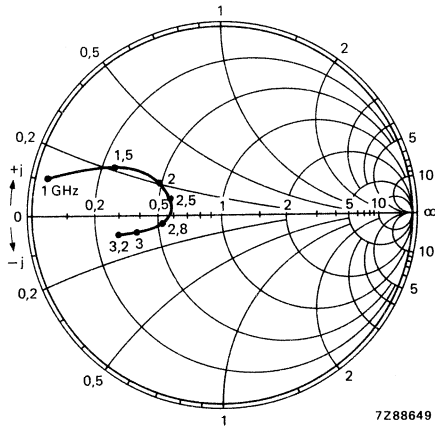

Fig. 17 Input impedance as a function of frequency.

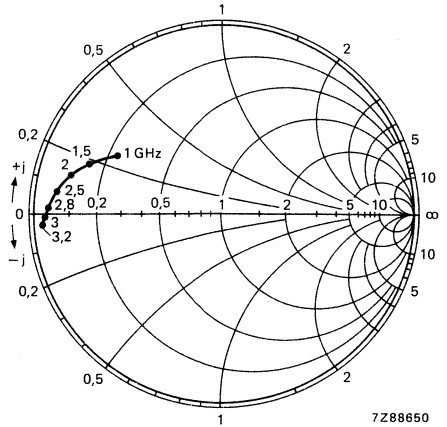

Fig. 18 Optimum load impedance as a function of frequency.

Conditions for Figs 17 and 18:

$V_{CE} = 28 \text{ V}$; class-B operation; $T_{mb} = 25 \text{ }^\circ\text{C}$; $Z_o = 50 \text{ } \Omega$; typical values.

PKB32005U

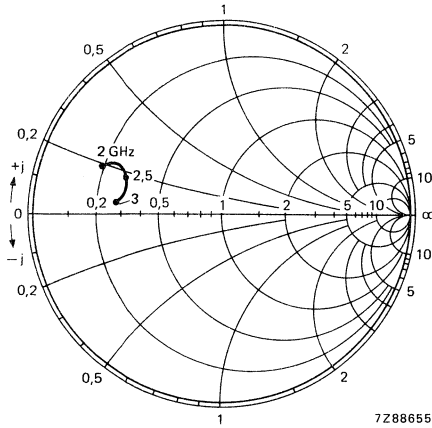

Fig. 19 Input impedance as a function of frequency.

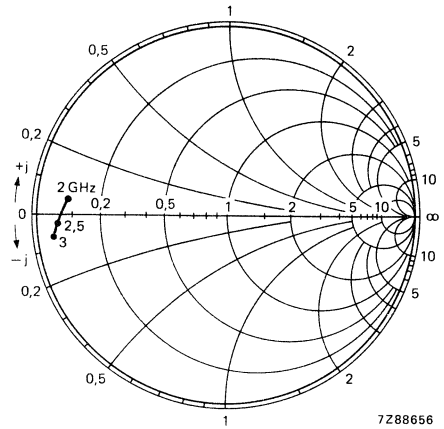

Fig. 20 Optimum load impedance as a function of frequency.

Conditions for Figs 19 and 20:

$V_{CE} = 28 \text{ V}$; class-B operation; $T_{mb} = 25 \text{ }^\circ\text{C}$; $Z_0 = 50 \text{ } \Omega$; typical values.



MICROWAVE POWER TRANSISTORS

N-P-N silicon transistors for use in common-base class-B power amplifiers up to 4,2 GHz.

Diffused emitter ballasting resistors, interdigitated structure, multicell geometry, localized thick oxide auto-alignment process and gold sandwich metallization ensure an optimum temperature profile and excellent performance and reliability.

QUICK REFERENCE DATA

R.F. performance up to $T_{mb} = 25\text{ }^{\circ}\text{C}$ in an unneutralized common-base class-B circuit

type number	mode of operation	f GHz	V_{CE} V	P_L W	G_p dB	η %	\bar{z}_i Ω	\bar{Z}_L Ω
PTB42001X	c.w.	4,2	24	typ. 1,3	typ. 7,5	typ. 33	110 + j0	2 - j0,5
PTB42002X	c.w.	4,2	24	typ. 2,3	typ. 7	typ. 35	36 + j58	2 - j7

MECHANICAL DATA

see page 2

This data must be read in conjunction with GENERAL SAFETY RECOMMENDATIONS—MICROWAVE SEMICONDUCTORS.

POTENTIAL HAZARD—BERYLLIUM OXIDE

This device contains beryllium oxide, the dust of which is toxic. The device is entirely safe, provided that the beryllium oxide disc is not damaged. Care should be taken to ensure that all those who may handle, use or dispose of this device are aware of its nature and of the necessary safety precautions. In particular, it should never be thrown out with general industrial or domestic waste.

MECHANICAL DATA

Fig. 1.

Base and metallic cap
connected to flange.

Torque on nut: max. 0,5 Nm

Recommended screw: M3

Marking code

RTC4001M = PTB42001X

RTC4002M = PTB42002X

Dimensions in mm

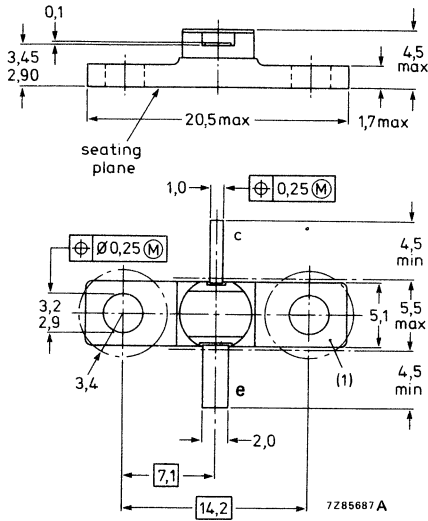

(1) Flatness of this area ensures full thermal contact with bolt head.



RATINGS

Limiting values in accordance with the Absolute Maximum System (IEC 134)

- Collector-base voltage
open emitter
- Collector-emitter voltage
 $R_{BE} = 10 \Omega$
open base
- Emitter-base voltage
open collector
- Collector current (d.c.)
- R.F. power dissipation ($f > 1 \text{ MHz}$)
up to $T_{mb} = 75 \text{ }^\circ\text{C}$
- Storage temperature
- Junction temperature
- Lead soldering temperature
at 0,3 mm from ceramic; $t_{sld} \leq 10 \text{ s}$

		PTB42001X	42002X	
V_{CBO}	max.	40	40	V
V_{CER}	max.	40	40	V
V_{CEO}	max.	15	15	V
V_{EBO}	max.	3,5	3,5	V
I_C	max.	0,25	0,5	A
P_{rf}	max.	5,5	10	W
T_{stg}		-65 to +200		$^\circ\text{C}$
T_j	max.	200		$^\circ\text{C}$
T_{sld}	max.	235		$^\circ\text{C}$

PTB42001X

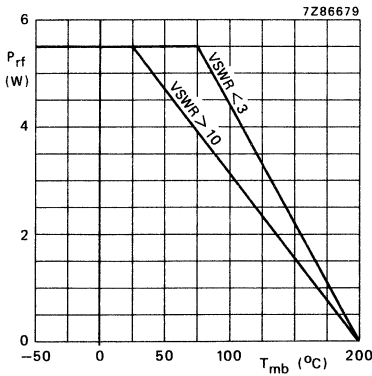

Fig. 2 Maximum permissible R.F. power dissipation as a function of mounting base temperature. $f > 1 \text{ MHz}$.

PTB42002X

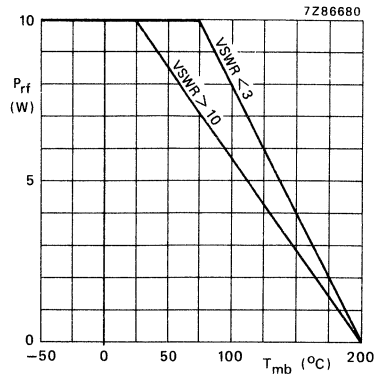

Fig. 3 Maximum permissible R.F. power dissipation as a function of mounting base temperature. $f > 1 \text{ MHz}$.

THERMAL RESISTANCE

- From junction to mounting base
- From mounting base to heatsink

		PTB42001X	42002X	
$R_{th \text{ j-mb}}$	max.	22	12	$^\circ\text{C/W}$
$R_{th \text{ mb-h}}$	max.	0,7	0,7	$^\circ\text{C/W}$

CHARACTERISTICS

Collector-base breakdown voltage

open emitter; $I_C = 1 \text{ mA}$

open emitter; $I_C = 2 \text{ mA}$

Collector-emitter breakdown voltage

$R_{BE} = 10 \Omega$; $I_C = 10 \text{ mA}$

Emitter-base breakdown voltage

open collector; $I_E = 0,5 \text{ mA}$

open collector; $I_E = 1,0 \text{ mA}$

Collector cut-off current

$I_E = 0$; $V_{CB} = 24 \text{ V}$

Emitter cut-off current

$I_C = 0$; $V_{EB} = 1,5 \text{ V}$

Collector-base capacitance at $f = 1 \text{ MHz}$

$I_E = I_C = 0$; $V_{CB} = 24 \text{ V}$; $V_{EB} = 1,5 \text{ V}$

Collector-emitter capacitance at $f = 1 \text{ MHz}$

$I_E = I_C = 0$; $V_{CB} = 24 \text{ V}$; $V_{EB} = 1,5 \text{ V}$

	PTB42001X	42002X	
$V_{(BR)CBO} \geq$	40	—	V
$V_{(BR)CBO} \geq$	—	40	V
$V_{(BR)CER} \geq$	40	40	V
$V_{(BR)EBO} \geq$	3,5	—	V
$V_{(BR)EBO} \geq$	—	3,5	V
$I_{CBO} \leq$	10	20	μA
$I_{EBO} \leq$	0,2	0,4	μA
C_{cb} typ.	2,2	3	pF
C_{ce} typ.	0,3	0,6	pF

APPLICATION INFORMATION (see also page 4)

PTB42001X

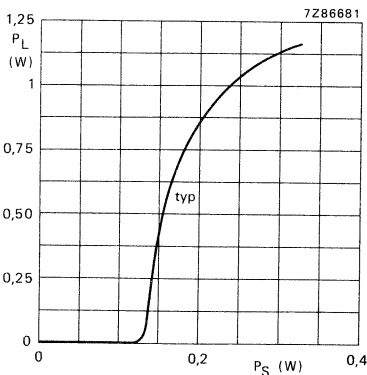

PTB42002X

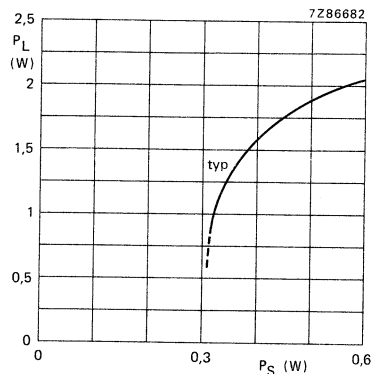

Fig. 4 Load power as a function of source power.

Fig. 5 Load power as a function of source power.

Conditions for Figs 4 and 5:

Class-B operation; $V_{CE} = 24 \text{ V}$; $f = 4,2 \text{ GHz}$; $T_{mb} = 25 \text{ }^\circ\text{C}$.

APPLICATION INFORMATION (see also page 3)

R.F. performance up to $T_{mb} = 25\text{ }^{\circ}\text{C}$ in an unneutralized common-base class-B circuit*

type number	mode of operation	f GHz	V_{CE} V	P_L W	G_p dB	η %	\bar{Z}_i Ω	\bar{Z}_L Ω
PTB42001X	c.w.	4,2	24	> 0,8 typ. 1,3	> 5 typ. 7,5	> 28 typ. 33	110 + j0	2 - j0,5
PTB42002X	c.w.	4,2	24	> 1,6 typ. 2,3	> 5 typ. 7	> 28 typ. 35	36 + j58	2 - j7

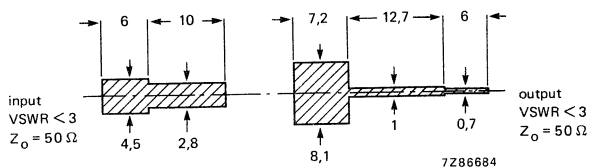

Fig. 6 Prematching test circuit boards for the PTB42001X at 4,2 GHz. (Dimensions in mm.)

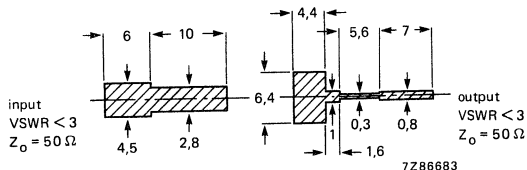

Fig. 7 Prematching test circuit boards for the PTB42002X at 4,2 GHz. (Dimensions in mm.)

Input striplines on a double Cu-clad printed-circuit board with PTFE fibre-glass dielectric ($\epsilon_r = 2,5$); thickness 1,6 mm.

Output striplines on a double Cu-clad Rexolite printed-circuit board with dielectric ($\epsilon_r = 2,4$); thickness 0,25 mm.

* Circuit consists of prematching circuit board in combination with complementary input and output slug tuners.

GALLIUM ARSENIDE FET TRANSISTORS



1. The first part of the document discusses the importance of maintaining accurate records of all transactions and activities. It emphasizes that this is crucial for ensuring transparency and accountability in the organization's operations.

≡ J

N-CHANNEL LOW-NOISE Ku-BAND GaAs FET

The transistor is housed in a miniature ceramic encapsulation and is specified in a low-noise amplifier circuit.

Features:

- Self-aligned process: high conformity and short gate length ($0,5 \mu\text{m}$);
- TiPtAu metallization ensures long life;
- Hermetically sealed encapsulation protects the chip to provide long term performance stability.

Also available in chip version (CFX13X).

QUICK REFERENCE DATA

Typical values in common-source configuration at $T_{\text{case}} = 25 \text{ }^\circ\text{C}$

mode of operation	f GHz	V_{DS} V	I_{D} mA	F_{opt} dB	G_{a} dB	g_{m}^* mA/V
c.w.	10	3	10	2,2	8	28
	12	3	10	2,5	7,5	28

* Measuring conditions: $-1 \text{ V} < V_{\text{GS}} < 0$

This data must be read in conjunction with GENERAL SAFETY RECOMMENDATIONS—MICROWAVE SEMICONDUCTORS.

MECHANICAL DATA

Fig. 1.

Source connected
to metallized lid

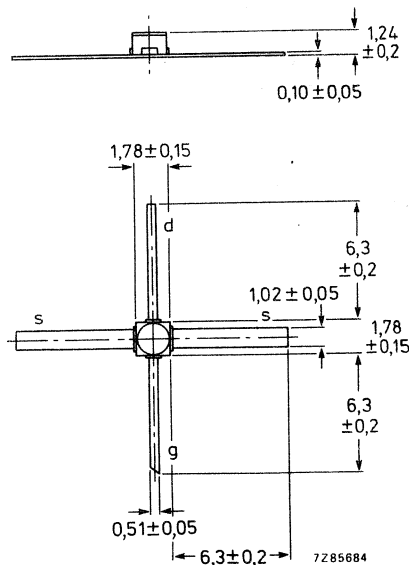

RATINGS

Limiting values in accordance with the Absolute Maximum System (IEC 134)

Drain-source voltage	V_{DS}	max.	5 V
Gate-source voltage	$-V_{GS}$	max.	6 V
Saturated drain current	I_{DSS}	max.	100 mA
Total power dissipation up to $T_{case} = 115\text{ }^{\circ}\text{C}$	P_{tot}	max.	300 mW
Storage temperature	T_{stg}		-65 to +175 $^{\circ}\text{C}$
Channel temperature	T_{ch}	max.	175 $^{\circ}\text{C}$
Lead soldering temperature up to 0,1 mm from transistor edge; $t_{sld} \leq 8\text{ s}$	T_{sld}	max.	250 $^{\circ}\text{C}$

THERMAL RESISTANCE

From channel to case

$R_{th\ ch-c} = 200\text{ }^{\circ}\text{C/W.}$

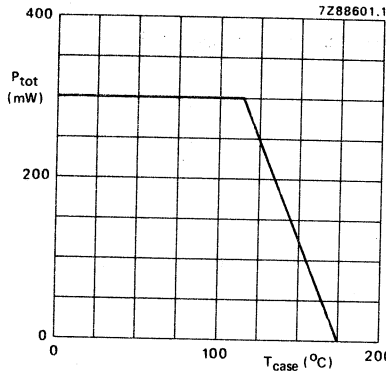

Fig. 2 Power derating curve as a function of case temperature.

CHARACTERISTICS

$T_{amb} = 25\text{ }^{\circ}\text{C}$

Gate-source cut-off current

$V_{DS} = 3\text{ V}; I_D = 200\text{ }\mu\text{A}$

I_G	typ.	1 μA
	<	5 μA

Saturated drain current

$V_{DS} = 3\text{ V}; V_{GS} = 0$

I_{DSS}		35 to 100 mA
-----------	--	--------------

Pinch-off voltage

$V_{DS} = 3\text{ V}; I_D = 200\text{ }\mu\text{A}$

$-V_{(P)GS}$	typ.	3 V
	1,5 to	4 V

Mutual transconductance

$V_{DS} = 3\text{ V}; -1\text{ V} < V_{GS} < 0$

g_m	>	25 mA/V
	typ.	28 mA/V

Maximum available gain

$V_{DS} = 3\text{ V}; I_D = 35\text{ mA}; f = 10\text{ GHz}$

G_{AM}	typ.	10,5 dB
----------	------	---------

$V_{DS} = 3\text{ V}; I_D = 35\text{ mA}; f = 12\text{ GHz}$

G_{AM}	typ.	9,0 dB
----------	------	--------

s-parameters (common source)

Typical values; $V_{DS} = 3\text{ V}$; $I_D = 10\text{ mA}$; $T_{amb} = 25\text{ }^\circ\text{C}$; $Z_o = 50\text{ }\Omega$

f GHz	s_{11}	s_{rs}	s_{fs}	s_{os}
6	0,91/-102°	0,027(-31,5)/27°	1,16(1,26)/81°	0,75/ -71°
7	0,89/-113°	0,025(-31,9)/28°	1,08(0,67)/68°	0,75/ -81°
8	0,88/-123°	0,025(-32,1)/32°	1,05(0,45)/57°	0,76/ -90°
9	0,86/-136°	0,026(-31,8)/38°	1,04(0,36)/44°	0,76/-100°
10	0,85/-151°	0,028(-31,2)/46°	1 (0)/31°	0,77/-108°
11	0,83/+ 160°	0,031(-30,1)/57°	0,94(-0,58)/20°	0,77/-114°
12	0,82/+ 165°	0,036(-28,9)/69°	0,87(-1,19)/12°	0,77/-117°

The figures given between brackets are values in dB.

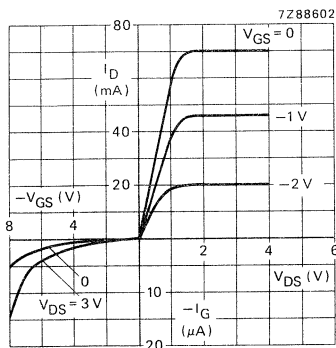

Fig. 3 Drain current as a function of drain-source voltage and gate cut-off current as a function of gate-source voltage. Typical values; $T_{case} = 25\text{ }^\circ\text{C}$.

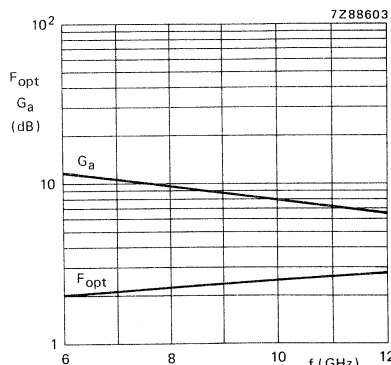

Fig. 4 Noise and associated gain as a function of frequency. Typical values; $V_{DS} = 3\text{ V}$; $I_D = 10\text{ mA}$.

APPLICATION INFORMATION

Low-noise amplifier (common-source) at $T_{case} = 25\text{ }^\circ\text{C}$

mode of operation	f GHz	V_{DS} V	I_D mA	F_{opt} dB	G_a dB
c.w.	12	3	10	< 3,0	> 6,5

Linear amplifier (common-source) at $T_{case} = 25\text{ }^\circ\text{C}$

mode of operation	f GHz	V_{DS} V	I_D mA	P_{L1} mW	G_{po} dB
c.w.	10	3	35	> 10	typ. 10

Conditions for Figs 5 and 6:

$V_{DS} = 3 \text{ V}; I_D = 10 \text{ mA};$

$T_{case} = 25 \text{ }^\circ\text{C}.$

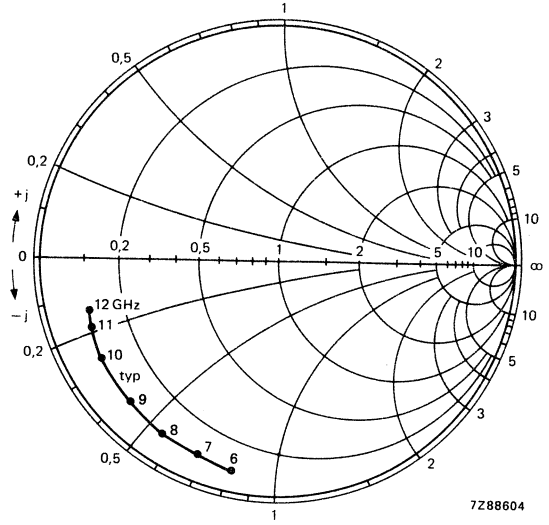

Fig. 5 Input impedance derived from input reflection coefficient s_{iS} co-ordinates in ohm $\times 50$.

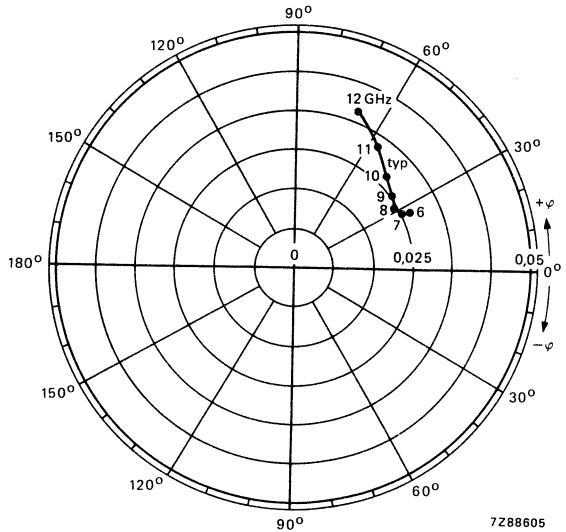

Fig. 6 Reverse transmission coefficient s_{rS} .



Conditions for Figs 7 and 8:

$V_{DS} = 3 \text{ V}$; $I_D = 10 \text{ mA}$;

$T_{case} = 25 \text{ }^\circ\text{C}$.

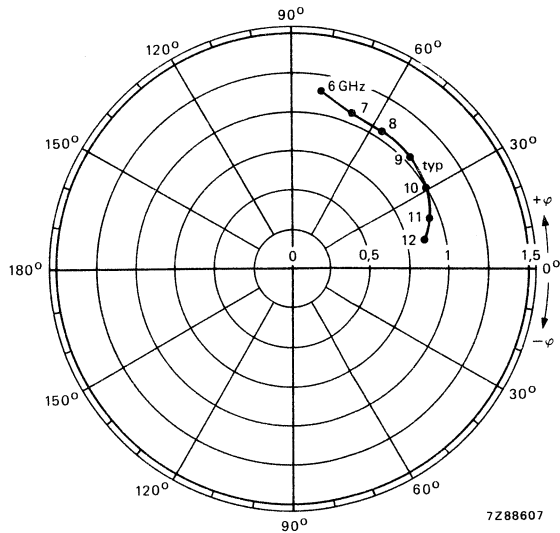
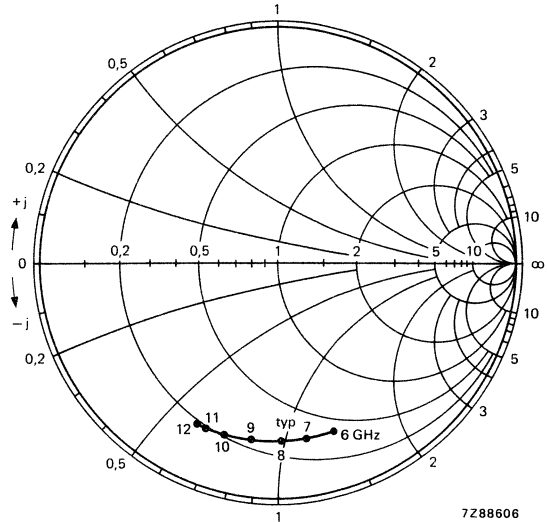

N-CHANNEL LOW-POWER X-BAND GaAs FET

The transistor is housed in a miniature ceramic encapsulation and is specified in a linear amplifier circuit.

Features:

- Self-aligned process: high conformity and short gate length ($0,8 \mu\text{m}$);
- TiPtAu metallization ensures long life;
- Hermetically sealed encapsulation protects the chip to provide high temperature stability.

Also available in chip version (CFX21X).

QUICK REFERENCE DATA

Typical values in common-source configuration at $T_{\text{case}} = 25 \text{ }^\circ\text{C}$

mode of operation	f GHz	V_{DS} V	I_{D} mA	P_{L1} mW	G_{po} dB	g_{m}^* mA/V
c.w.	8	6	40	80	10	23
	11	6	40	65	7,5	23

* Measuring conditions: $V_{\text{DS}} = 3 \text{ V}$; $-1 \text{ V} < V_{\text{GS}} < 0$

This data must be read in conjunction with GENERAL SAFETY RECOMMENDATIONS—MICROWAVE SEMICONDUCTORS.

MECHANICAL DATA

Dimensions in mm

Fig. 1.

Source connected to metallized lid.

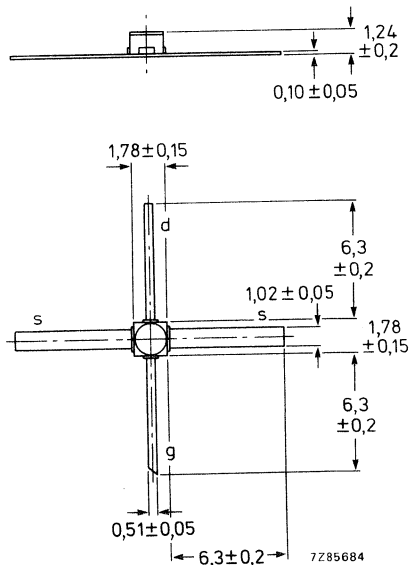

RATINGS

Limiting values in accordance with the Absolute Maximum System (IEC 134)

Drain-source voltage	V_{DS}	max.	8 V
Gate-source voltage	$-V_{GS}$	max.	6 V
Saturated drain current	I_{DSS}	max.	110 mA
Total power dissipation up to $T_{case} = 75\text{ }^{\circ}\text{C}$	P_{tot}	max.	500 mW
Storage temperature	T_{stg}	-65 to +175	$^{\circ}\text{C}$
Channel temperature	T_{ch}	max.	175 $^{\circ}\text{C}$
Lead soldering temperature up to 0,1 mm from transistor edge; $t_{sld} \leq 8\text{ s}$	T_{sld}	max.	250 $^{\circ}\text{C}$

THERMAL RESISTANCE

From channel to case $R_{th\ ch-c} = 200\text{ }^{\circ}\text{C/W.}$

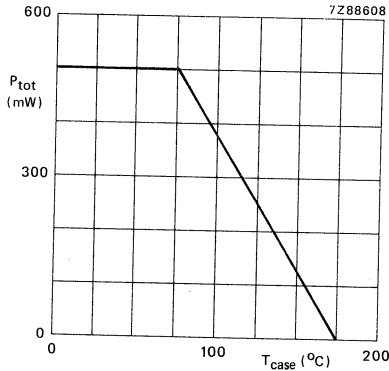

Fig. 2 Power derating curve as a function of case temperature.

CHARACTERISTICS

$T_{case} = 25\text{ }^{\circ}\text{C}$

Saturated drain current

$V_{DS} = 3\text{ V}; V_{GS} = 0$

Pinch-off voltage

$V_{DS} = 3\text{ V}; I_D = 200\text{ }\mu\text{A}$

Mutual transconductance

$V_{DS} = 3\text{ V}; -1\text{ V} < V_{GS} < 0$

I_{DSS} 50 to 110 mA

$-V(P)GS$ 1,5 to 5 V

g_m > 20 mA/V

s-parameters (common source)

Typical values; $V_{DS} = 6\text{ V}$; $I_D = 40\text{ mA}$; $T_{amb} = 25\text{ }^\circ\text{C}$; $Z_o = 50\text{ }\Omega$

f GHz	s_{is}	s_{rs}	s_{fs}	s_{os}
6	0,87/-119°	0,010(-40,4)/63°	1,18(1,44)/68°	0,86/-69°
7	0,85/-132°	0,012(-38,3)/79°	1,08(0,66)/54°	0,87/-79°
8	0,82/-146°	0,018(-34,8)/89°	1,02(0,15)/40°	0,87/-89°
9	0,81/-162°	0,028(-31,1)/91°	0,96(-0,35)/26°	0,88/-98°
10	0,80/-177°	0,038(-28,4)/89°	0,88(-1,12)/12°	0,90/-107°
11	0,78/+175°	0,051(-25,9)/87°	0,80(-1,97)/ 2°	0,91/-111°
12	0,76/+171°	0,065(-23,8)/88°	0,73(-2,73)/-5°	0,92/-113°

The figures given between brackets are values in dB.

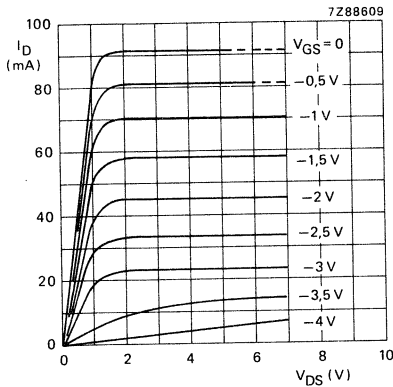

Fig. 3 Typical values; $T_{case} = 25\text{ }^\circ\text{C}$.

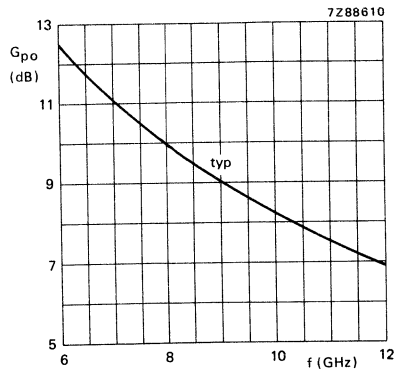

Fig. 4 Linear gain as a function of frequency.
 $V_{DS} = 6\text{ V}$; $I_D = 40\text{ mA}$.

APPLICATION INFORMATION

Linear amplifier (common-source) at $T_{case} = 25\text{ }^\circ\text{C}$

mode of operation	f GHz	V_{DS} V	I_D mA	P_{L1} mW	G_{po} dB	g_m mA/V
c.w.	11	6	40	> 50	> 7	> 20

Low-noise amplifier (common-source) at $T_{case} = 25\text{ }^\circ\text{C}$

mode of operation	f GHz	V_{DS} V	I_D mA	F dB	G_a dB
c.w.	10	3	10	typ. 3,5	typ. 7

Conditions for Figs 5 and 6:

$V_{DS} = 6 \text{ V}; I_D = 40 \text{ mA};$

$T_{case} = 25 \text{ }^\circ\text{C}.$

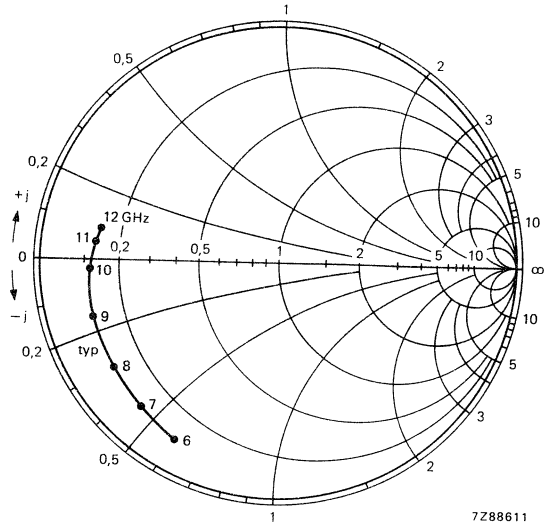

Fig. 5 Input impedance derived from input reflection coefficient s_{1S} co-ordinates in ohm $\times 50$.

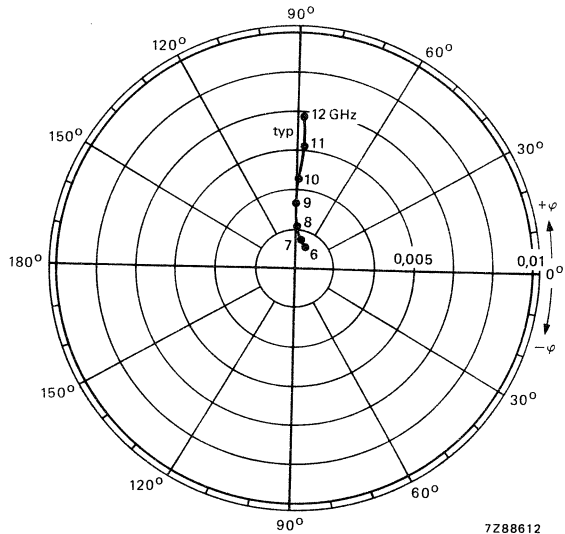

Fig. 6 Reverse transmission coefficient s_{rS} .

Conditions for Figs 7 and 8:
 $V_{DS} = 6 \text{ V}$; $I_D = 40 \text{ mA}$;
 $T_{case} = 25 \text{ }^\circ\text{C}$.

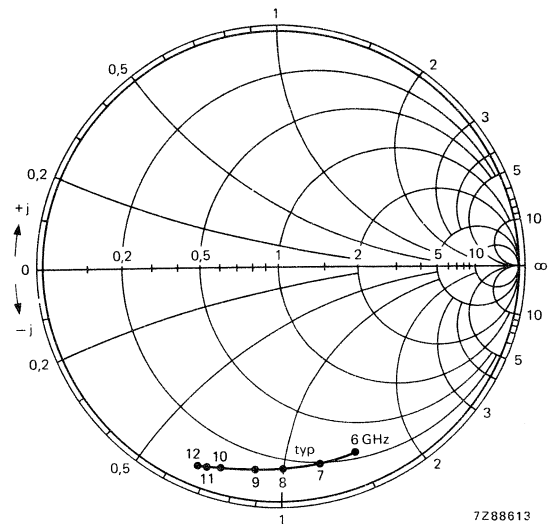

Fig. 7 Output impedance derived from output reflection coefficient s_{OS} co-ordinates in ohm x 50.

7288613

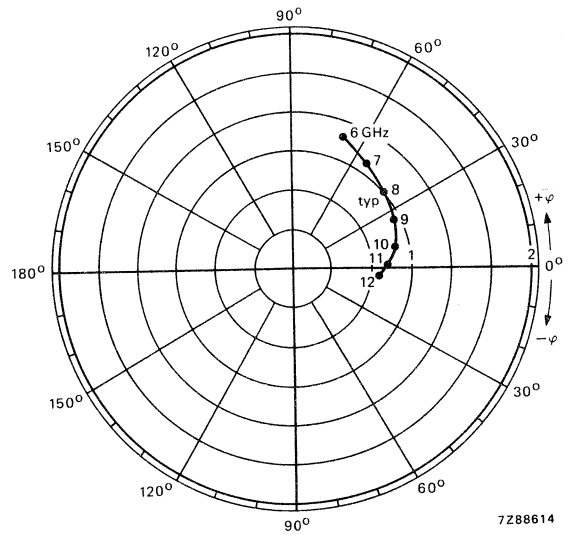

Fig. 8 Forward transmission coefficient s_{FS} .

7288614

OSCILLATORS

≡ K

X-BAND GUNN OSCILLATOR

Solid state oscillator featuring wide electronic tuning range. Designed for applications in local oscillators employing a.f.c. systems.

QUICK REFERENCE DATA

Centre frequency		9.4	GHz
Electronic tuning range	min.	200	MHz
Mechanical tuning range	min.	± 50	MHz
Supply voltage		-7.0	V
Power output	typ.	5.0	mW
Output connector		WG.16/WR.90	

This data must be read in conjunction with GENERAL SAFETY RECOMMENDATIONS – MICROWAVE SEMICONDUCTORS

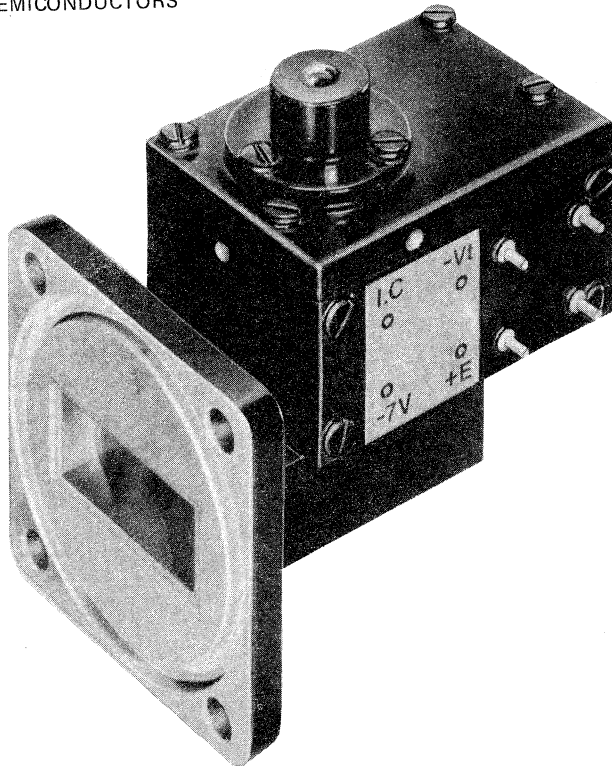

→ MECHANICAL DATA

Dimensions in mm

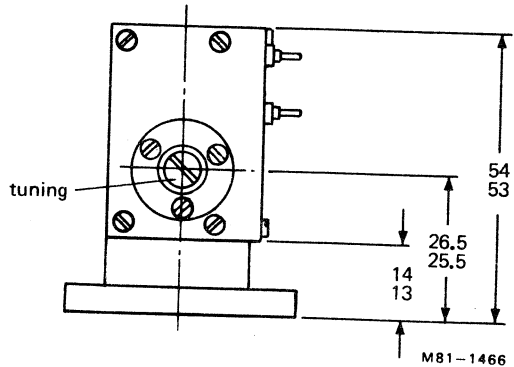
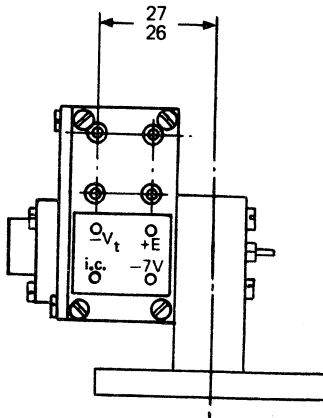
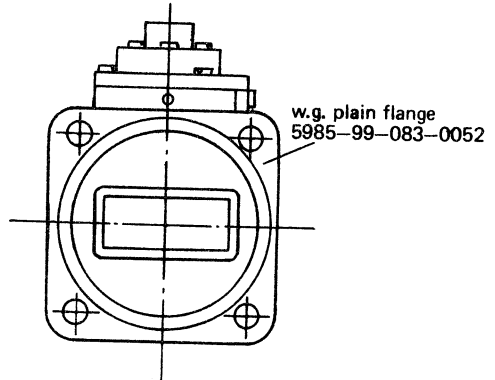

RATINGS (at 25 °C)

Limiting values in accordance with the Absolute Maximum System (IEC134)

Operating temperature range	-30 to +70	°C
Supply voltage	max. -8.0	V
Gunn current, operating	max. 200	mA
starting	max. 250	mA
Tuning voltage	max. -12	V
Tuning current	max. 2.0	mA
Load v.s.w.r.	max. 1.5:1	



OPERATING CONDITIONS (typical)

Supply voltage (note 1)	-7.0	V
Supply current	140	mA
Tuning voltage range	0 to -10	V
Tuning current	1.0	mA

CHARACTERISTICS at 25 °C

Centre frequency	9.4	GHz		
	min.	typ.	max.	
Electronic tuning range	200	250	—	MHz
Mechanical tuning range	± 50	—	—	MHz
Power output (note 2)	3.0	5.0	—	mW
Variation in power output over electronic tuning range	—	1.5	—	dB
Electronic tuning sensitivity	—	25	—	MHz/V
Frequency temperature coefficient	—	-1.0	—	MHz/°C
Frequency pushing	—	30	—	MHz/V

Notes

1. The oscillator circuit provides some protection against forward transients greater than -8V but care should be taken to avoid such transients as far as possible.
2. Power output min. is measured under all conditions of tuning.

ELECTRONIC TUNING

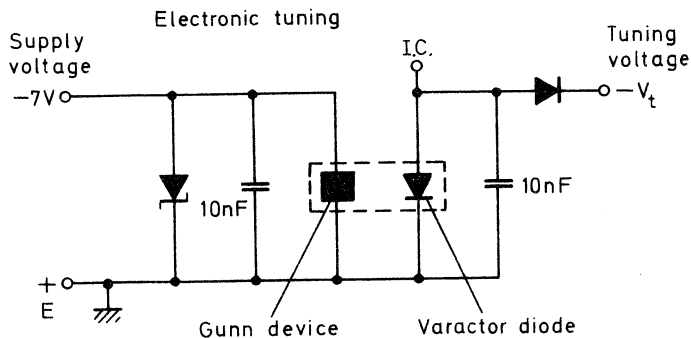

D6579



X-BAND GUNN OSCILLATORS

This is a series of Gunn oscillators with fixed frequencies in X-band. Applications include all forms of miniature radar systems. A suffix S indicates that the device operates as a self-oscillating mixer (auto detector).

QUICK REFERENCE DATA

Type No.	Centre frequency GHz		
CL8630, CL8630S	10.687		
CL8631, CL8631S	9.35		
CL8632, CL8632S	9.47		
CL8633, CL8633S	10.525		
Supply voltage		+7.0	V
Power output (at 7.0 V)	typ.	8.0	mW
Frequency temperature coefficient	typ.	-0.25	MHz/°C
Output is via a square plain flange WG16. WR90. 5985-99-083-0052			

This data must be read in conjunction with GENERAL SAFETY RECOMMENDATIONS – MICROWAVE SEMICONDUCTORS

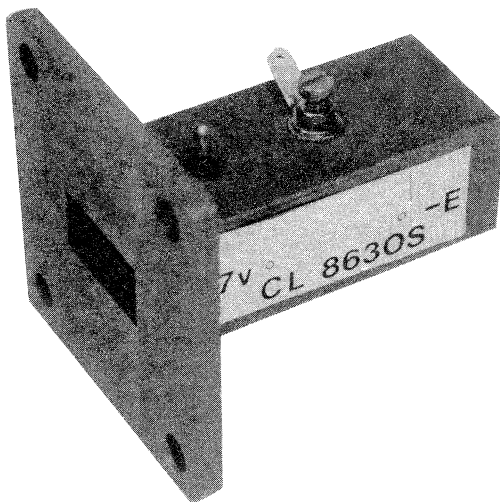

RATINGS (at 25 °C)

Limiting values in accordance with the Absolute Maximum System (IEC134)

Supply voltage (d.c.)	max.	+7.5	V
Supply voltage (for less than 1 ms)	max.	+9.0	V
Supply current, threshold	max.	200	mA
Supply current, operating	max.	160	mA
Temperature range		0 to +40	°C

CHARACTERISTICS

	min.	typ.	max.	
Power output (at 7.0 V)	5.0	10.0	—	mW
Frequency temperature coefficient	—	0.25	-0.4	MHz/°C
Second harmonic	—	-35	—	dBm
Threshold current	—	—	225	mA
Gunn operating current	—	120	160	mA
Frequency pushing	—	4.0	—	MHz/V
Frequency (fixed)	—	—	—	—
CL8630, CL8630S	10.675	10.687	10.699	GHz
CL8631, CL8631S	9.338	9.350	9.362	GHz
CL8632, CL8632S	9.458	9.470	9.482	GHz
CL8633, CL8633S	10.513	10.525	10.537	GHz

A.M. noise to carrier ratio (1 Hz to 1 kHz bandwidth)

CL8630 to CL8633	—	-94	—	dB
------------------	---	-----	---	----

Output voltage for input 66 dB down on output power (at 12 dB min. $\frac{\text{signal} + \text{noise}}{\text{noise}}$)

CL8630S to CL8633S	80	120	—	μV
--------------------	----	-----	---	---------------

OPERATING NOTES (4 and 5 apply only to CL8630 to CL8633 and notes 6, 7 and 8 only to CL8630S to CL8633S).

- The active element will be damaged if the supply voltage is reversed. Care should be taken to avoid transients in excess of 9 volts. An 8.2 V 5% voltage regulator diode to shunt the power supply is recommended for this purpose.
- The minimum supply voltage is 6.5 V for the frequency of oscillation to remain within the characteristic limits.
- It is recommended that a small capacitor (e.g. 10 nF) is connected across the oscillator terminals to suppress low frequency oscillation which may occur in the power supply.
- When used in a Doppler radar system, modulation of the oscillator supply voltage within the 1 Hz to 1 kHz band will degrade the a.m. signal to noise ratio at the output of the associated mixer, as a result of direct conversion by the Gunn device to both a.m. and f.m. noise components. The a.m. component will contribute directly and the f.m. component may contribute from demodulation by the slope of the bandpass characteristic of the the mixer. The f.m. component may be demodulated by the non-linear response characteristic of the associated detecting element.

5. Second harmonic level is measured into a W.G.16 load with a v.s.w.r. $<1.1:1$ at fundamental frequency. The level is equivalent to that radiated from a low v.s.w.r. X-band antenna, for example, our ACX-01A.
6. A return signal 66 dB down on radiated power will be achieved from a man target of radar cross-section 1.0 m^2 at a range of 12 m, when operating with an antenna gain of 20 dB.
7. System bandwidth 1 Hz to 1 kHz.
8. Power supply ripple in the amplifier passband will degrade the signal to noise performance.

CL8630 SERIES

MECHANICAL DATA

CL8630
CL8630S
CL8633
CL8633S

Dimensions in mm

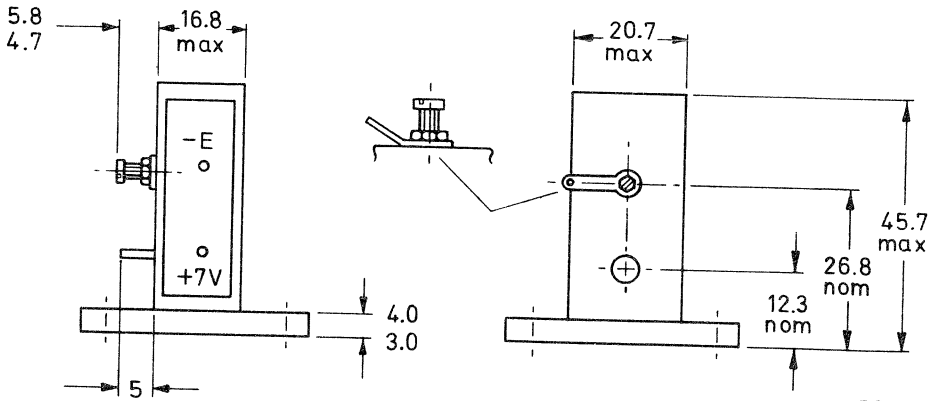
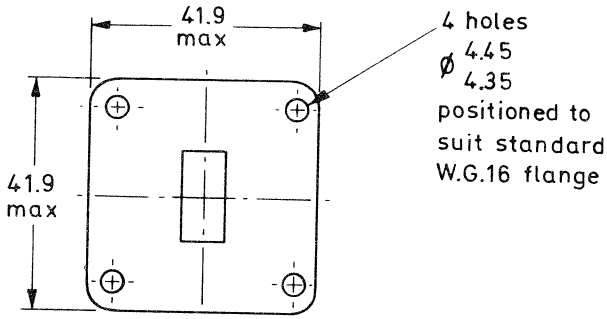

MECHANICAL DATA

Dimensions in mm

CL8631
 CL8631S
 CL8632
 CL8632S

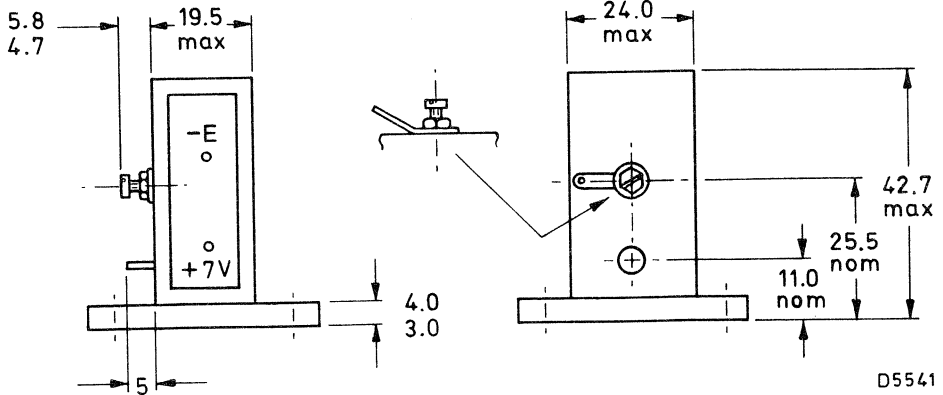
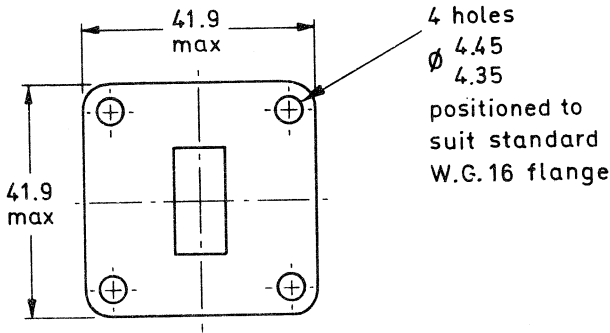

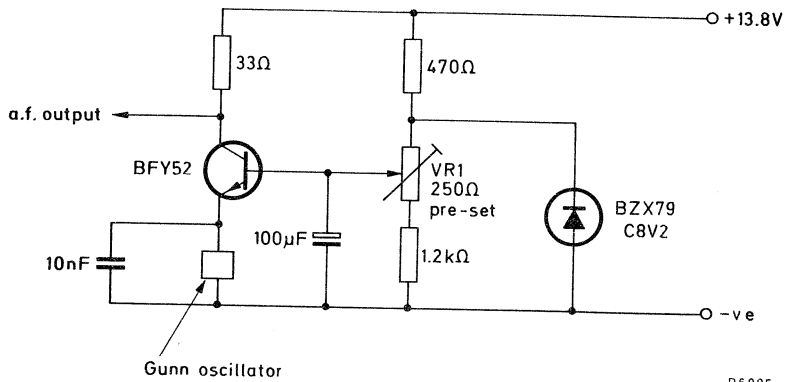

D6005

VR₁ is used to set voltage at 7.0 V across Gunn oscillator.

Circuit used for sensitivity measurement (self-oscillating versions only).



The issue of the information contained in this publication does not imply any authority or licence for the utilisation of any patented feature.

X-BAND GUNN OSCILLATORS

Mechanically and electronically tuned Gunn-effect oscillators in the 10.5 GHz band. The high Q cavity offers frequency stability compatible with application as the transmitter (CL8640T) and receiver local oscillator (CL8640R) in short range data link systems.

QUICK REFERENCE DATA

		CL8640R	CL8640T	
Centre frequency		10.49	10.56	GHz
Mechanical tuning range	min.	120	120	MHz
Electronic tuning range	min.	30	8.0	MHz
Power output	typ.	6.0	6.0	mW
Operating voltage		-7.0	-7.0	V

Output via square plain flange WG.16. WR.90. 5985-99-083-0052

This data must be read in conjunction with GENERAL SAFETY RECOMMENDATIONS – MICROWAVE SEMICONDUCTORS

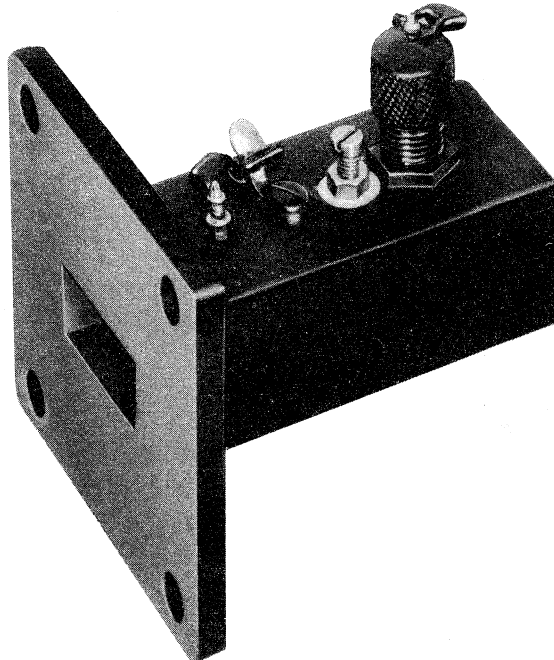

→ RATINGS

Limiting values in accordance with the Absolute Maximum System (IEC134)

	CL8640R	CL8640T	
Storage temperature range	T_{stg} -30 to +100	-30 to +100	°C
Operating temperature range	T_{amb} -15 to +70	-15 to +70	°C
Supply voltage	max.	-7.2	V
Supply voltage (transient)	max.	-8.0	V
Tuning voltage	max.	-12	V
Tuning current	max.	100	µA
Load v.s.w.r.	max.	1.5:1	

TYPICAL OPERATING CONDITIONS

Supply voltage (note 1)		-7.0	V
Starting current		250	mA
Gunn operating current		170	mA
Tuning voltage range (modulation) (note 2)	CL8640R	-0.5 to -7.5	V
	CL8640T	-0.5 to -1.5	V

→ CHARACTERISTICS ($T_{amb} = 25$ °C)

Centre frequency	CL8640R (tuning voltage -2.5V)	10.49	GHz
	CL8640T (tuning voltage -1.0V)	10.56	GHz

		min.	typ.	max.	
Mechanical tuning range		±60	—	—	MHz
Electronic tuning range (note 2)	CL8640R	±15	—	—	MHz
	CL8640T	±4.0	—	—	MHz
Power output at -7.0 V		4.0	6.0	—	mW
Gunn operating current		—	170	180	mA
Frequency pushing		—	3.0	—	MHz/V
Frequency pulling (note 3)		—	1.5	—	MHz
Frequency temperature coefficient		—	-0.25	-0.3	MHz/°C
Tuning current		—	—	10	µA

Notes

1. The Gunn device will be damaged if the supply voltage is reversed. Care should be taken to avoid transients in the supply voltage.
2. The electronic tuning provided by the varactor diode circuit is non-linear, following an approximately exponential rate of change of capacitance at low tuning voltages.
3. V.S.W.R. = 1.5:1

MECHANICAL DATA

Dimensions in mm

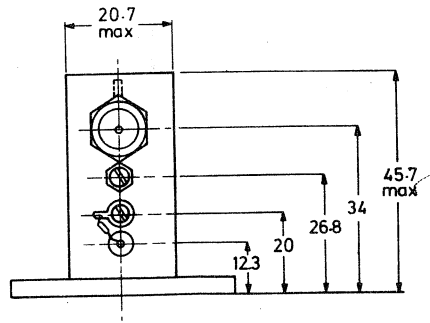
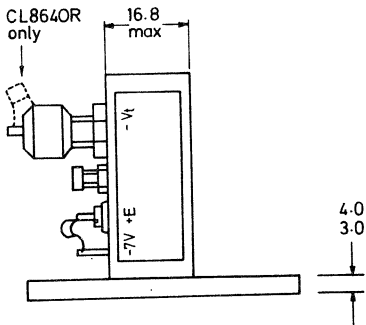
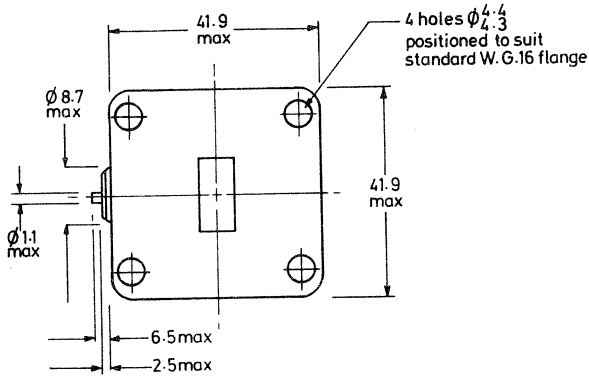

D6294

X-BAND GUNN OSCILLATOR

This is an electronically and mechanically tuned oscillator suitable for use as a solid state replacement for reflex klystrons. It may be used as a local oscillator in marine radar systems. The device has been tested to ensure its compliance with the requirements of Board of Trade specification BOT SBN 115 10057/1.

QUICK REFERENCE DATA

Output connector		WG16	
Centre frequency		9.375	GHz
Mechanical tuning range	min.	± 75	MHz
Electronic tuning range	min.	± 25	MHz
Power output	min.	5	mW
Operating voltage		-7.5	V

This data must be read in conjunction with GENERAL SAFETY RECOMMENDATIONS – MICROWAVE SEMICONDUCTORS

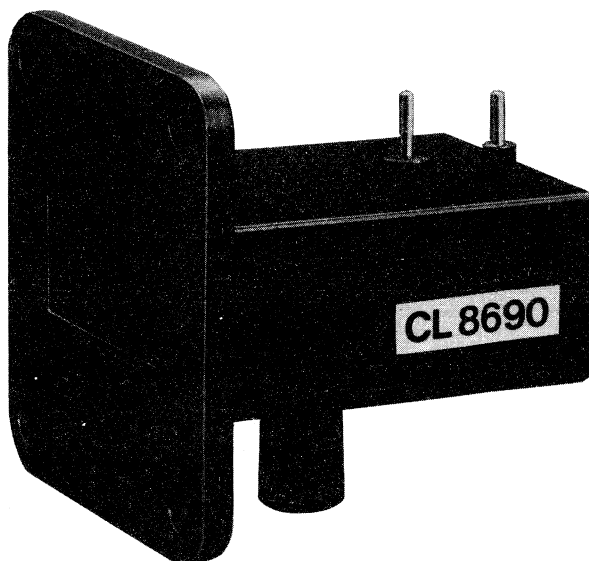

TYPICAL OPERATING CONDITIONS

Supply voltage d.c. (note 1)	-7.5 V
Gunn operating current	160 mA
Tuning voltage range (notes 1 and 2)	-1 to -12 V
Tuning current	10 μ A

→ LIMITING VALUES at 20 °C

In accordance with the Absolute Maximum System (IEC134)

Supply voltage	max.	-8 V
Supply voltage (for less than 1 ms)	max.	-9 V
Tuning voltage	max.	-15 V
Tuning current	max.	100 μ A
Storage temperature range		-45 to +85 °C
Ambient operating temperature range		-15 to +50 °C

CHARACTERISTICS at 20 °C

Centre frequency (note 4)	9.375 GHz
---------------------------	-----------

	min.	typ.	max.	
Mechanical tuning range	± 75	± 100	—	MHz
Electronic tuning range	± 25	± 30	—	MHz
Power output (note 5)	5	8	—	mW
Gunn operating current (note 3)	—	160	200	mA
Frequency deviation over temperature range	—	± 15	± 25	MHz
Frequency pushing	—	10	15	MHz/V
Frequency pulling (note 6)	—	—	20	MHz
Mechanical tuning rate	—	—	250	MHz/turn

Notes

1. The Gunn diode will be damaged if the supply voltage is reversed. In addition, care should be taken to avoid transients in the supply voltage as far as possible.
2. The tuning supply voltage should have a source impedance of less than 1 k Ω .
3. During the switch-on period, the Gunn diode current will rise to a peak of up to 300 mA at approximately -4 V and then fall to the specified operating current at -7.5 V.
4. The centre frequency is measured with supply voltages of -7.5 V to the Gunn device and -5 V to the varactor diode.
5. Power output is measured under all conditions of tuning and temperature.
6. The load v.s.w.r. is 1.3 max. Frequency pulling is measured over all phases of mismatch.

APPLICATION NOTES

1. Three solder pins are provided for connection of the supply voltages and the earth contact.
2. To prevent parasitic low frequency oscillation, a $1 \mu\text{F}$ capacitor is connected across the Gunn device.
3. The centre frequency may be set within the limits given in the characteristics, by turning the screw.
4. A $8.2 \text{ V} \pm 5\%$ zener diode should be connected across the Gunn device supply for transient protection.

MECHANICAL DATA

Dimensions in mm

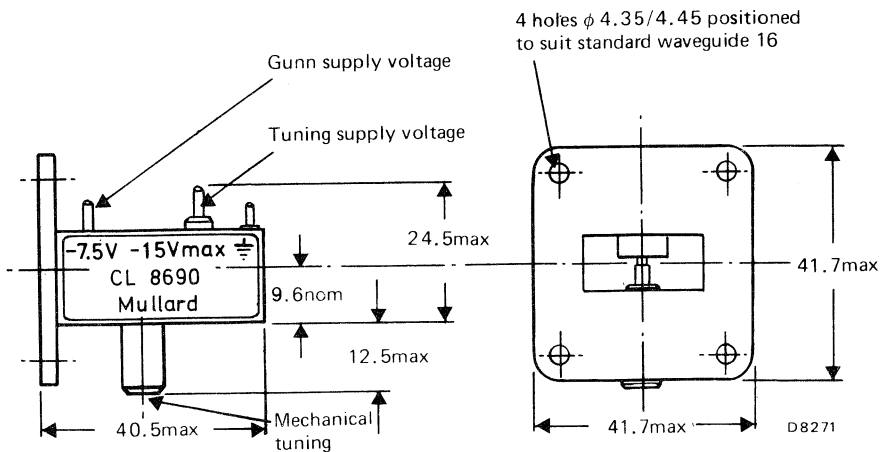
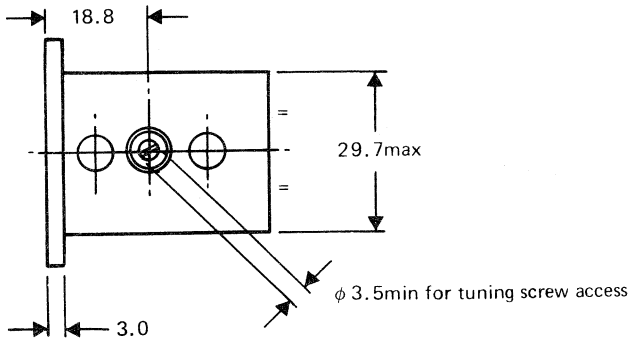

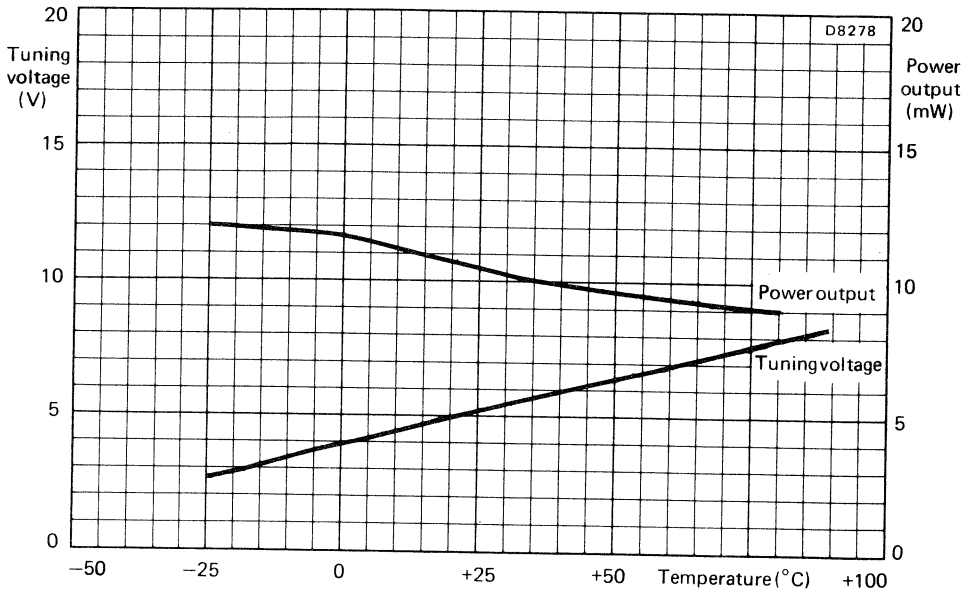

Typical power output and tuning voltage as a function of temperature.
(Output frequency constant at 9.385 GHz)

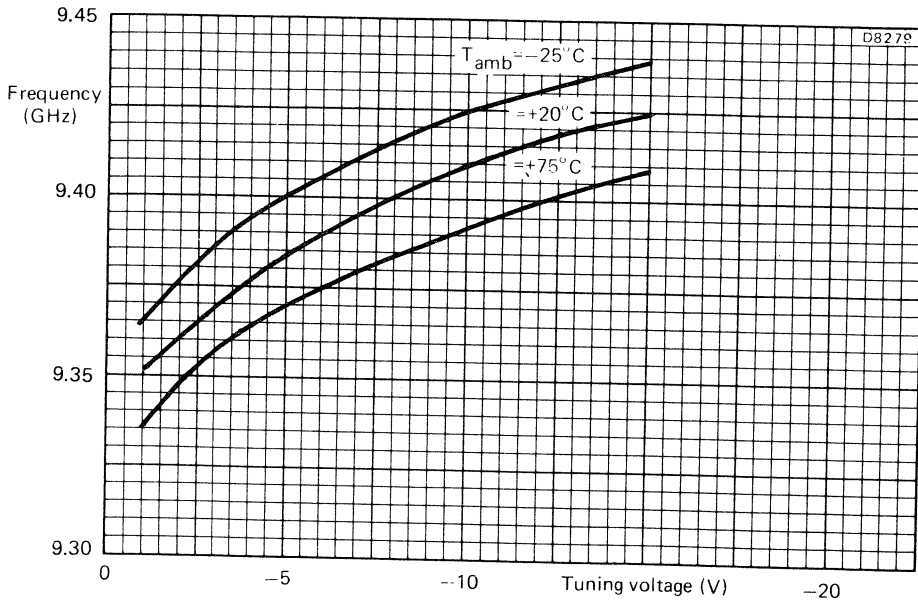

Typical output frequency as a function of tuning voltage at three ambient temperatures

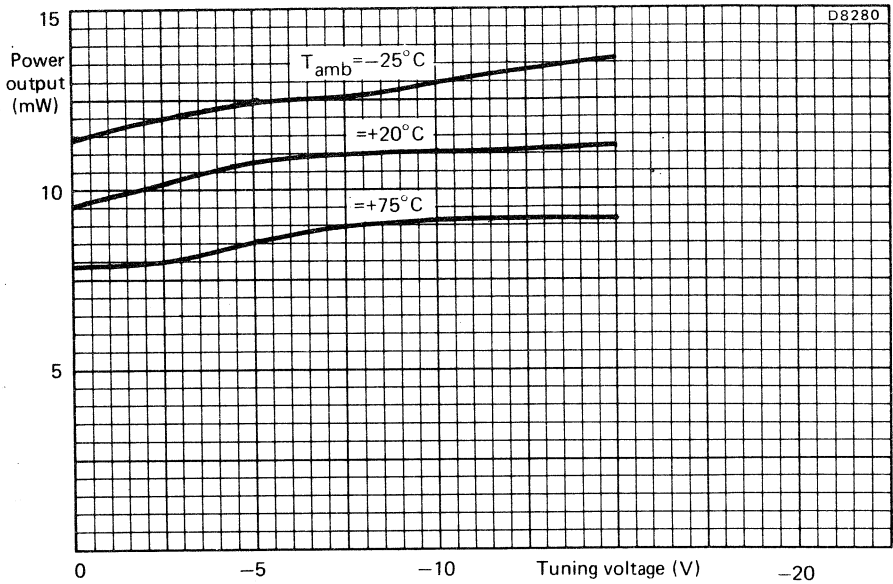

Typical power output as a function of tuning voltage at three ambient temperatures

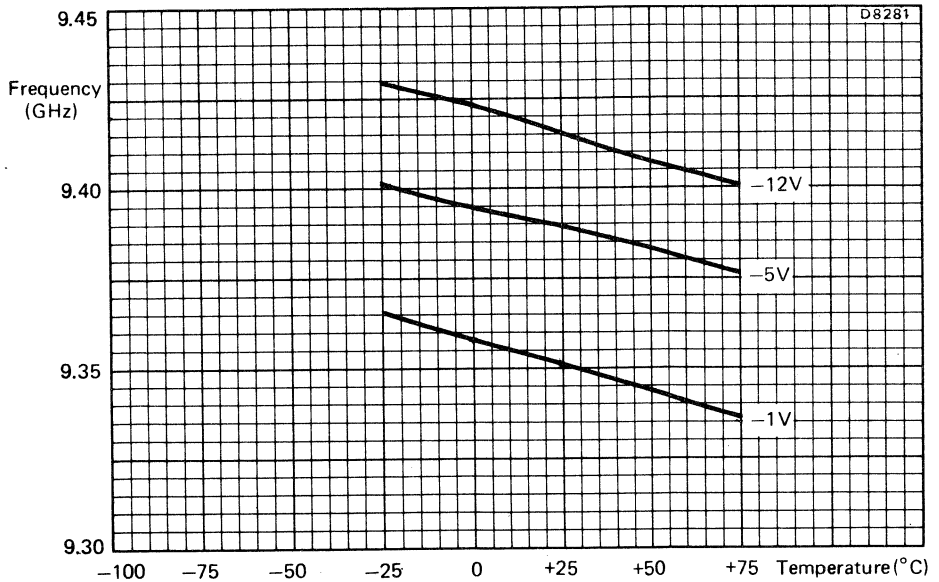

Typical output frequency as a function of temperature at three tuning voltages.

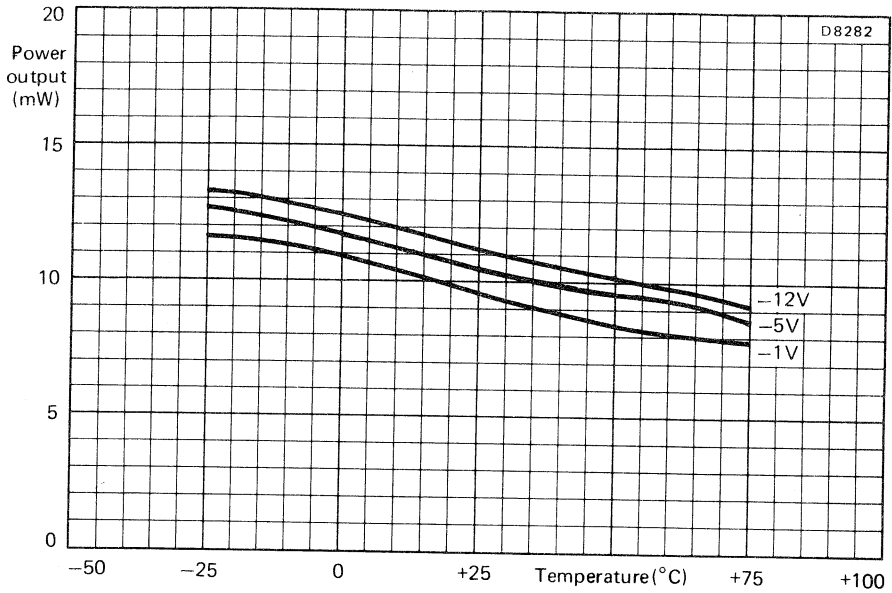

Typical power output as a function of temperature at three tuning voltages



LOW NOISE STABLE IMPATT OSCILLATOR

Direct generating low noise stable oscillator specially designed for 11 GHz microwave link transmitters and receivers and similar equipment. It consists of a temperature compensated high Q transmission cavity to which an IMPATT diode is coupled via a coaxial circuit. The cavity is hermetically sealed and filled with dry nitrogen. Mechanical tuning facilities for frequency adjustment and power optimization are built in.

QUICK REFERENCE DATA

Frequency band	10,7 to 11,2 GHz, type JS1001 11,2 to 11,7 GHz, type JS1002
Mechanical tuning range	500 MHz
Stability $\frac{\Delta f}{f}$	better than $\pm 5 \cdot 10^{-7}/^{\circ}\text{C}$
F.M. noise	< 1,2 Hz in a 100 Hz band
Output power	max. 125 mW

This data must be read in conjunction with GENERAL SAFETY RECOMMENDATIONS – MICROWAVE SEMICONDUCTORS

OPERATING CONDITIONS

Supply voltage	max. +80 V (d.c.)
Supply current	min. 35 mA max. 65 mA
Current stabilized power supply required.	
Ambient operating temperature	-30 to +60 °C
Ambient humidity	0 to 95 %

CHARACTERISTICS at 25 °C and $I_D = 55 \text{ mA}$

Frequency band	10,7 to 11,2 GHz, type JS1001 11,2 to 11,7 GHz, type JS1002
Mechanical tuning range	500 MHz
Frequency stability $\frac{\Delta f}{f}$	better than $\pm 5 \cdot 10^{-7}/^{\circ}\text{C}$
Frequency pushing $\frac{\Delta f}{\Delta I_D}$	max. 10 kHz/mA
Frequency pulling Δf (measured with output isolator into output mismatch with V.S.W.R. of 1,5)	max. 10 kHz

Harmonic level	< -50 dBc *
Spurious signal	< -70 dBc
F.M. noise $\Delta f_{r.m.s.}$ at 100 kHz off carrier	< 1,2 Hz in a 100 Hz band
A.M. noise $\frac{P_{AM}}{P_{carrier}}$	< -115 dB
P out to be adjusted by varying diode current (see curve)	up to max. 125 mW

Ordering information

Type	Catalogue number
JS1001	9360 019 10112
JS1002	9360 019 20112

MECHANICAL DATA

Dimensions in mm

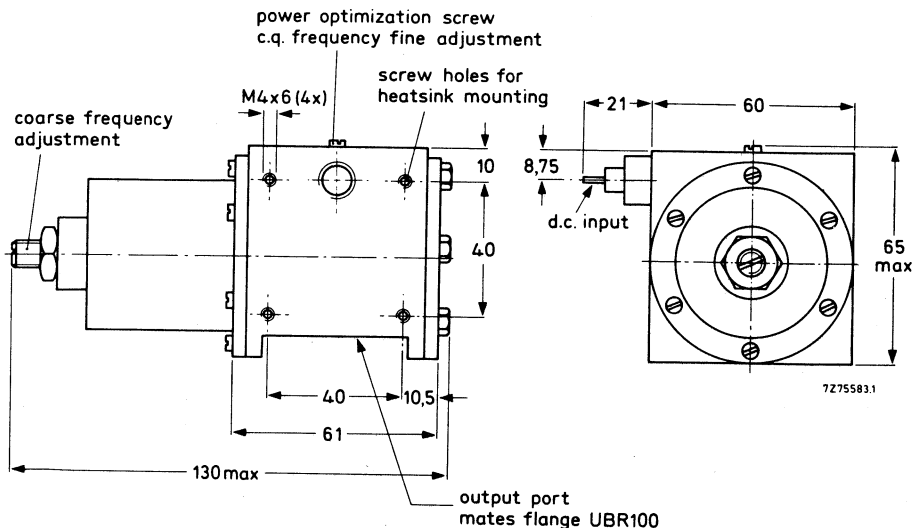

Fig. 1 Stable IMPATT oscillator.

* Measured without coaxial line between oscillator output and analyser. When a coaxial line is used between the oscillator and the analyser these values will be greatly reduced.

COAXIAL OUTPUT ADAPTOR, type 2722 162 02841

Consists of a waveguide to coax SMA female transition with built in isolator.

Frequency range	10,7 to 11,7	GHz
Isolation	> 25	dB
Insertion loss	< 0,4	dB
V.S.W.R. waveguide	< 1,05	
SMA connector	< 1,2	
Maximum power load	2	W
Temperature range	-10 to +70	°C

Mechanical data of adaptor

Material	brass and aluminium
Mating flange type	IEC-UBR 100
Connector type	SMA female 50
Dimensions	see Fig. 2.

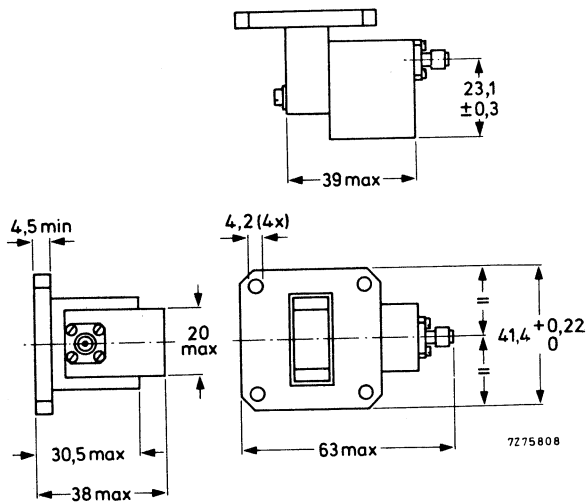

Fig.2 Coaxial output adaptor.

OPERATING NOTES

1. Positive voltage must be applied to the soldering pin; otherwise the active element will be damaged.
2. To adjust output power level at a particular frequency, bias current is increased from the start oscillation value (approximately 30 mA) until the required output power is obtained roughly. With the small screw, see Fig. 1, the output power is then maximized, after which bias current can be accurately set for the desired power.
3. Accurate setting of the desired frequency is obtained by adjusting and locking the main tuning screw as well as possible. The power optimization screw is now slightly detuned from its position obtained in 2 to afford the residual fine tuning of frequency. Generally the associated output power degradation is then very small, see Fig. 3. If necessary, the procedures 2 and 3 can be repeated.

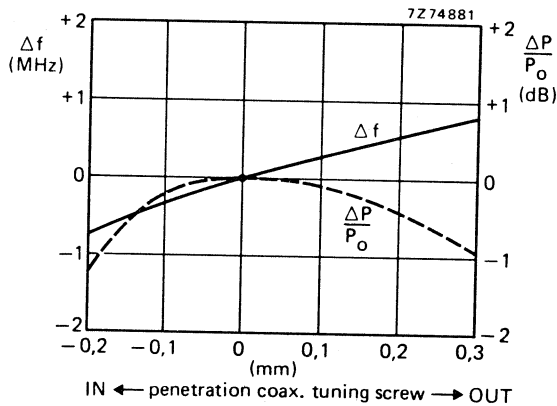

Fig. 3 Fine tuning Δf and associated power variation as a function of the coaxial tuning screw position at constant cavity tuning $I_D = 55$ mA; $P_O = 110$ mW; $f = (11\,000 + \Delta f)$ MHz.

4. It is recommended that a filter be connected across the oscillator supply voltage terminal, see Fig. 4, to suppress low frequency oscillations which may occur in the power supply.

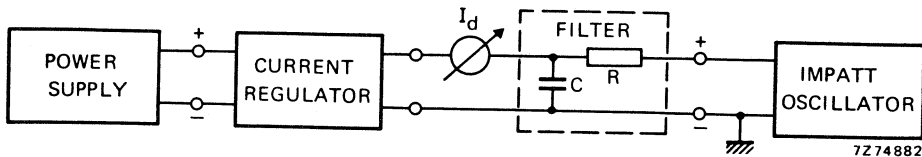

Fig. 4 Bias configuration for stable IMPATT oscillator. $R = 82 \Omega$ (carbon resistor, 1 W), $C = 220$ nF (film capacitor 160 V). Power supply: 110 V, 100 mA.

TYPICAL PERFORMANCE CURVES

The performance of JS1002 is similar to that of JS1001.

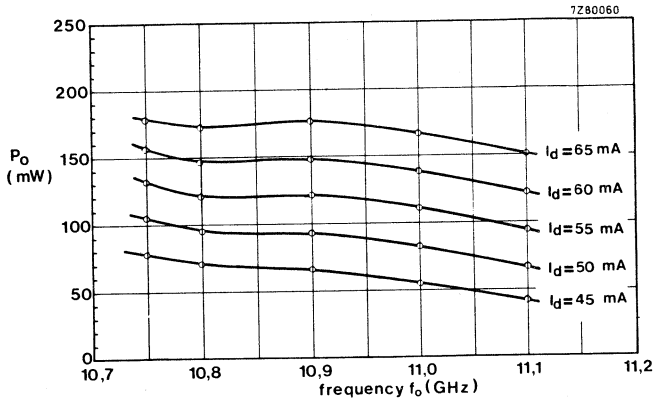

Fig. 5 Output power as a function of frequency for the IMPATT oscillator with diode current I_d as a parameter.

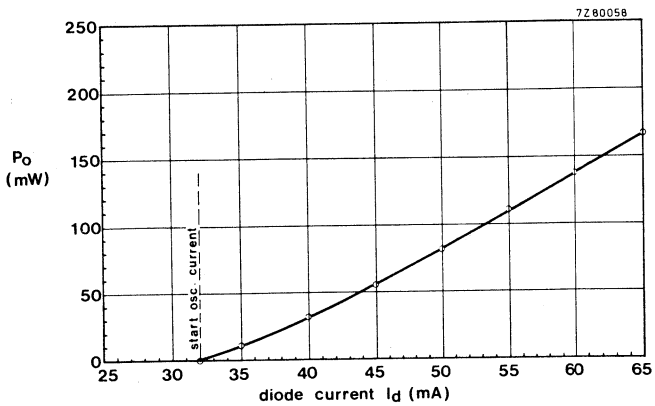

Fig. 6 Output power of the IMPATT oscillator, measured as a function of the diode current I_d at $f_o = 11$ GHz.

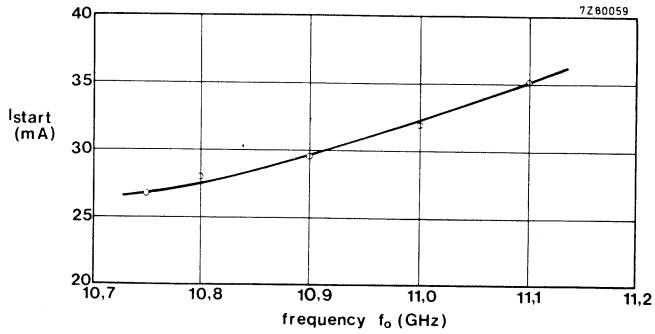

Fig. 7 Start oscillation current as a function of frequency, ambient temperature 25 °C.

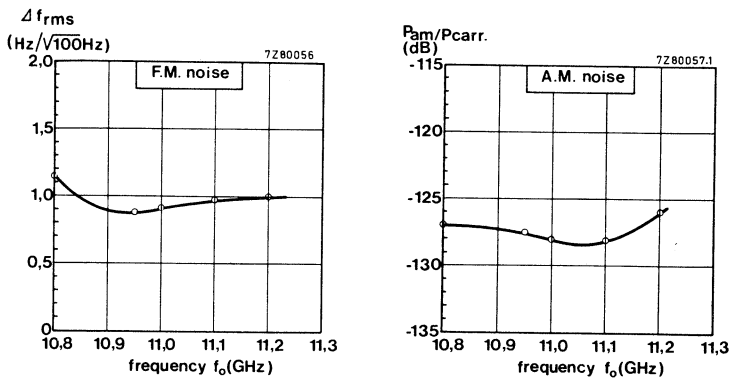

Fig. 8 A.M. and F.M. noise of the IMPATT oscillator, measured as a function of the carrier frequency in a bandwidth of 100 Hz at $f_m = 100$ kHz. $I_d = \text{constant} = 55$ mA.

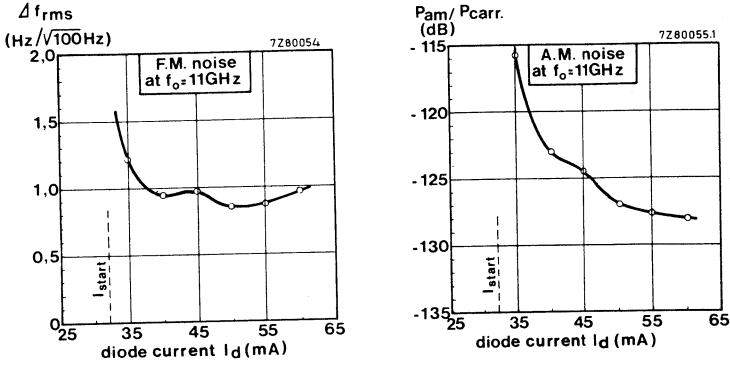

Fig. 9 A.M. and F.M. noise of the IMPATT oscillator, measured as a function of the diode current (output power) in a bandwidth of 100 Hz at $f_m = 100$ kHz.

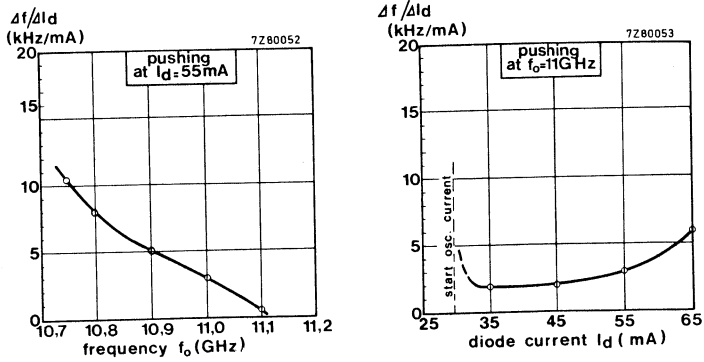

Fig. 10 Pushing of the IMPATT oscillator, measured as a function of frequency and diode current.

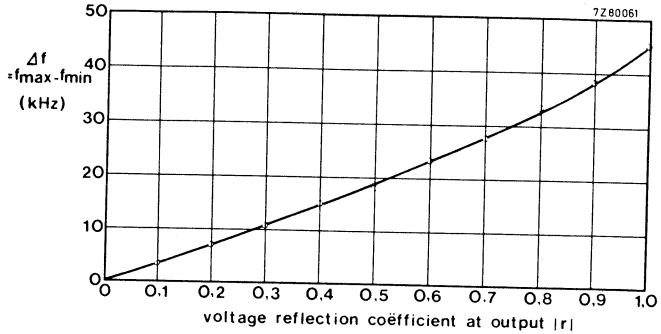

Fig. 11 Frequency pulling of the IMPATT oscillator as a function of the modulus of the voltage reflection coefficient. (Output via isolator and OSM connector.) $I_d = 55$ mA, $f_o = 11$ GHz, $P_o = 110$ mW.

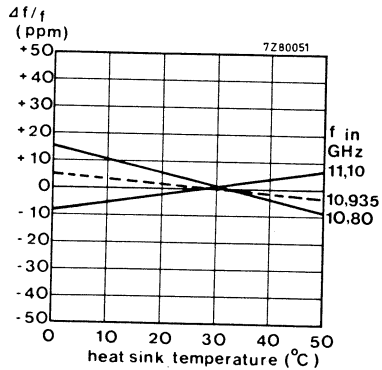
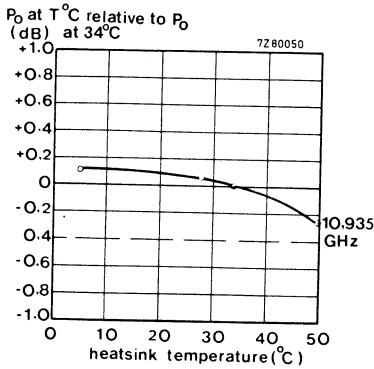

Fig. 12 Relative change of output power and frequency with heatsink temperature. $I_d = 55$ mA.

LOW NOISE STABLE GUNN OSCILLATOR

Direct generating low noise stable oscillator specially designed for 11 GHz microwave link transmitters and receivers and similar equipment. It consists of a temperature compensated high Q transmission cavity to which a Gunn diode is coupled via a coaxial circuit. The cavity is hermetically sealed and filled with dry nitrogen. Mechanical tuning facilities for frequency adjustment and power optimization are built in.

QUICK REFERENCE DATA

Frequency band	10,7 to 11,2 GHz, type JS1101 11,2 to 11,7 GHz, type JS1102
Mechanical tuning range	500 MHz
Stability $\frac{\Delta f}{f}$	Better than $\pm 5 \times 10^{-7}/^{\circ}\text{C}$
F.M. noise Δf_{rms}	< 0,5 Hz in a 100 Hz band
Output power*	min. 70 mW

This data must be read in conjunction with GENERAL SAFETY RECOMMENDATIONS – MICROWAVE SEMICONDUCTORS

OPERATING CONDITIONS

Supply voltage	fixed; between 11 and 12 V (d.c.)
$P_{\text{tot max}}$ at mounting base temperature = 70 °C	6 W
Voltage stabilized power supply required.	
Ambient operating temperature	-30 to +60 °C
Ambient humidity	0 to 95 %

CHARACTERISTICS at 25 °C and $V_d = 12 \text{ V}$

Frequency band	10,7 to 11,2 GHz, type JS1101 11,2 to 11,7 GHz, type JS1102
Mechanical tuning range	500 MHz
Frequency stability $\frac{\Delta f}{f}$	better than $\pm 5 \times 10^{-7}/^{\circ}\text{C}$
Frequency pushing $\frac{\Delta f}{\Delta V_d}$	max. 100 kHz/V
Frequency pulling Δf (measured with output isolator into output mismatch with V.S.W.R. of 1,5)	max. 10 kHz

* Other output powers available on request.

Harmonic level	< - 50 dBc*
Spurious signal	< - 70 dBc
F.M. noise Δf_{rms} at 100 kHz off carrier	< 0,5 Hz in a 100 Hz band
A.M. noise $\frac{P_{AM}}{P_{carrier}}$ at 100 kHz off carrier	< - 130 dB in a 100 Hz band

Ordering information

Type	Catalogue number
JS1101	9360 021 00001
JS1102	9360 021 10001

MECHANICAL DATA

Dimensions in mm

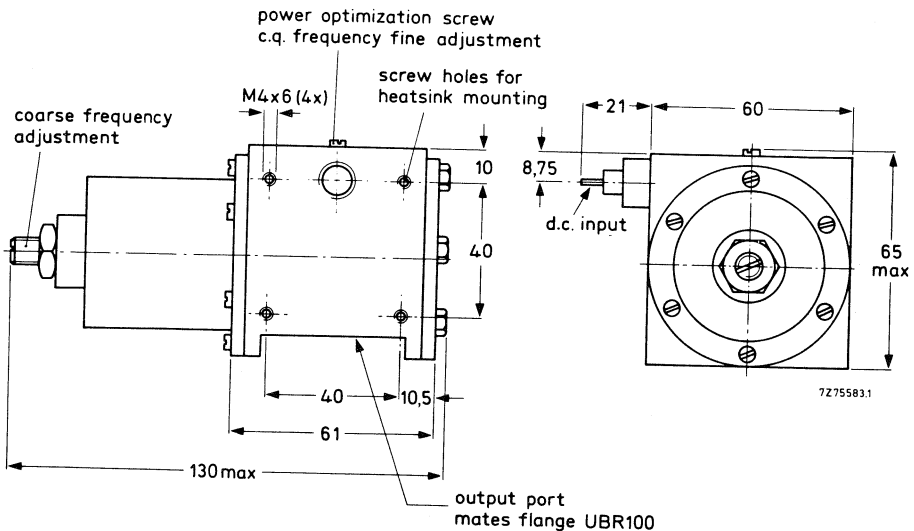

Fig. 1 Stable Gunn oscillator.

* Measured without coaxial line between oscillator output and analyser. When a coaxial line is used between the oscillator and the analyser these values will be greatly reduced.

COAXIAL OUTPUT ADAPTOR, type 2722 162 02841

Consists of a waveguide to coaxial SMA female transition with built in isolator.

Frequency range	10,7 to 11,7 GHz
Isolation	> 25 dB
Insertion loss	< 0,4 dB
V.S.W.R. waveguide	< 1,05
SMA connector	< 1,2
Maximum power load	2 W
Temperature range	-10 to +70 °C

Mechanical data of adaptor

Material	brass and aluminium
Mating flange type	IEC-UBR 100
Connector type	SMA female 50
Dimensions	see Fig. 2.

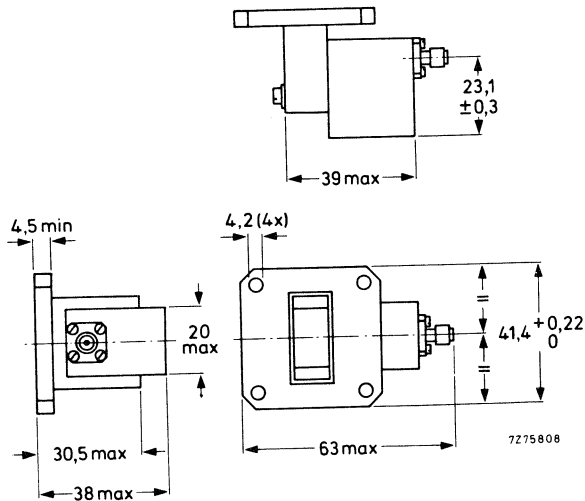

Fig. 2 Coaxial output adaptor.

OPERATING NOTES

1. Positive voltage must be applied to the soldering pin; otherwise the active element will be damaged.
2. The power supply should be low-impedance voltage-regulated and capable of supplying approximately 1,5 times the normal operating current to initiate oscillations.
3. It is recommended that an RC filter be connected in parallel with a voltage regulator diode across the oscillator supply voltage terminals. The filter prevents low-frequency bias supply oscillations, while the regulator diode protects the Gunn diode from over voltage. See Fig. 3.

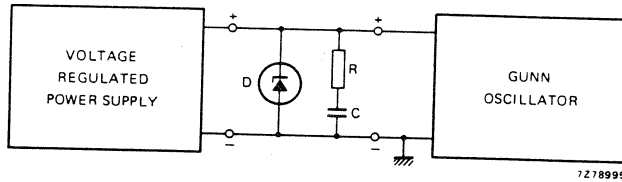

Fig. 3 Bias configuration for stable Gunn oscillator.
 D = voltage regulator diode, e.g. BZX70-C15;
 R = 1 to 10 Ω , carbon resistor;
 C = 0,47 μ F, film capacitor;
 Power supply up to 15 V, min. 1 A.

4. The voltage across the oscillator terminals is set to a fixed value between 11 and 12 V d.c. The power delivered by the oscillator must be optimized at the desired frequency by means of the small screw. See Fig. 1.
5. Accurate setting of the desired frequency is obtained by adjusting and locking the main tuning screw as well as possible. The power optimization screw is now slightly detuned from its position obtained in 4 to afford the residual fine tuning of frequency. Generally the associated output power degradation is then very small. see Fig. 4. If necessary, the procedures 4 and 5 can be repeated.

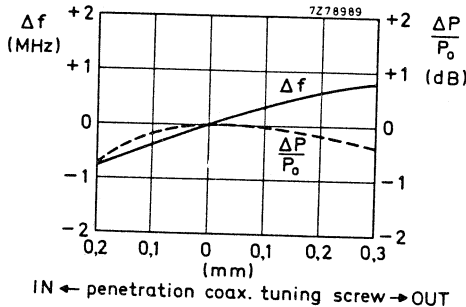

Fig. 4 Fine tuning Δf and associated power variation as a function of the coaxial tuning screw position at constant cavity tuning. $V_d = 12$ V; $P_0 = 88$ mW; $f = (11\,000 + \Delta f)$ MHz.

TYPICAL PERFORMANCE CURVES

The performance of JS1102 is similar to that of JS1101.

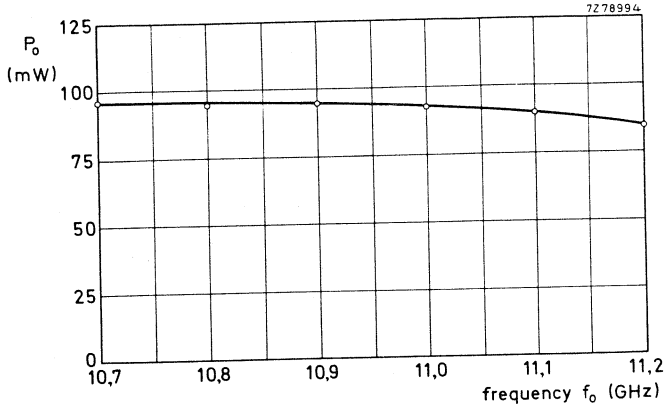

Fig. 5 Output power as a function of frequency for the Gunn oscillator with diode voltage $V_D = 12$ V.

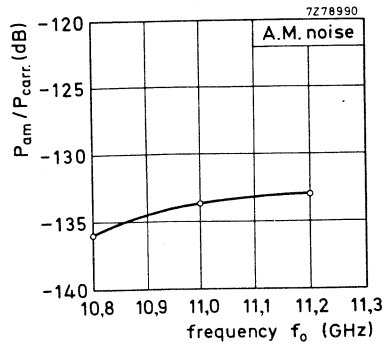
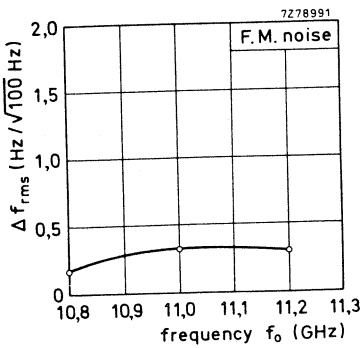

Fig. 6 A.M. and F.M. noise of the Gunn oscillator, measured as a function of the carrier frequency in a bandwidth of 100 Hz at $f_m = 100$ kHz. $V_D = 12$ V.

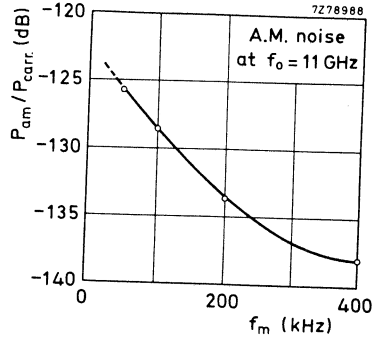
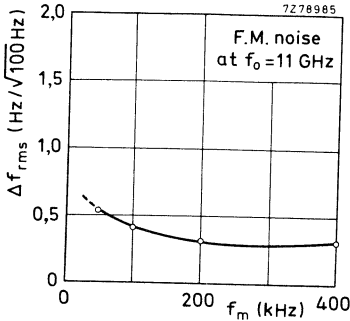

Fig. 7 A.M. and F.M. noise of the Gunn oscillator, measured in a bandwidth of 100 Hz at modulation frequencies (f_m) near to the carrier.

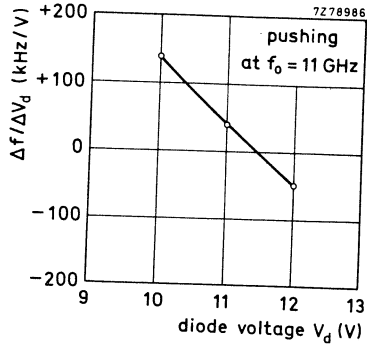
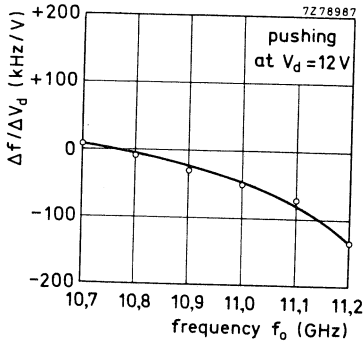

Fig. 8 Pushing of the Gunn oscillator, measured as a function of frequency and diode voltage.

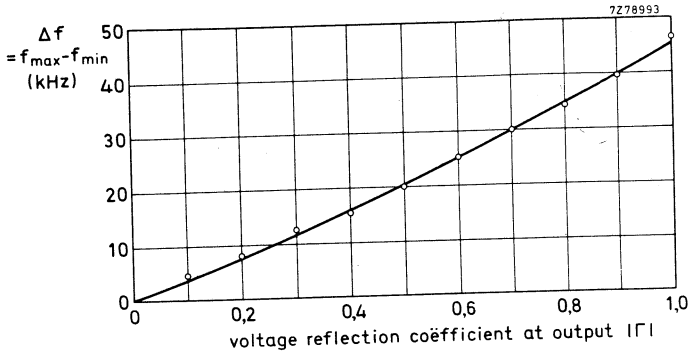

Fig. 9 Frequency pulling of the Gunn oscillator as a function of the modulus of the voltage reflection coefficient. (Output via isolator and OSM connector.) $V_d = 12$ V; $f_o = 11$ GHz; $P_o = 88$ mW; $I_d = 495$ mA.

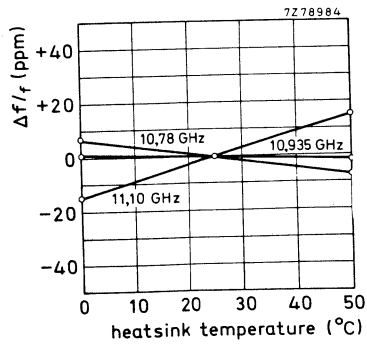
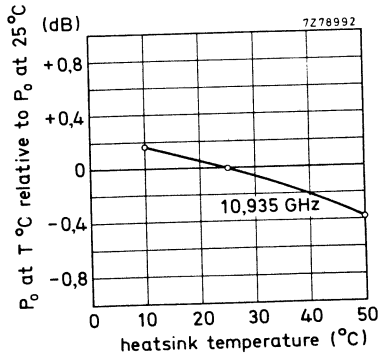

Fig. 10 Relative change of output power and frequency with heatsink temperature. $V_d = 12$ V.

DIELECTRIC RESONATOR STABILIZED OSCILLATOR

In this type of oscillator, with a Gunn-diode as the active element, high stability and low f.m. noise are obtained by using a small, high-Q, dielectric (ceramic) resonator as the frequency determining element.

Special features are:

- inexpensive
- small and lightweight
- high stability and low noise.

The oscillator is intended for applications as a local oscillator in radar and telecommunication equipment. Higher power output versions are suitable for transmitter applications.

QUICK REFERENCE DATA

Frequency	can be specified between 9 to 12 GHz
Output power at $V_d = -8$ V	20 mW
Stability $\frac{\Delta f}{f}$ (-20 to +60 °C), without tuning	better than $-4.10^{-6}/^{\circ}\text{C}$
F.M. noise Δf_{rms} at 100 kHz off carrier	typ. 0,15 Hz in a 1 Hz band

This data must be read in conjunction with GENERAL SAFETY RECOMMENDATIONS -- MICROWAVE SEMICONDUCTORS

OPERATING CONDITIONS

Gunn oscillator	typ.	-8 V
supply voltage (d.c.)	typ.	220 mA
operating current		2,5 W
$P_{\text{tot max}}$ at mounting base temperature = 70 °C		
Voltage stabilized power supply required		
Storage temperature range		-55 to +125 °C
Ambient operating temperature range		-20 to +60 °C

CHARACTERISTICS at $T_{\text{amb}} = 25$ °C and $V_d = -8$ V

Frequency (to be specified)	typ.	≈ 11 GHz*
Mechanical tuning range, see operating notes, note 4	up to	5 %
Operating current	typ.	220 mA
Output power		20 mW*
Frequency stability $\frac{\Delta f}{f}$ (-20 to +60 °C), without tuning, see operating notes, note 4		better than $-4.10^{-6}/^{\circ}\text{C}$
Frequency pushing $\frac{\Delta f}{\Delta V_d}$	<	1 MHz/V
Frequency pulling Δf_p , measured without isolation into output mismatch with VSWR of 1,5		2,5 MHz

* Other output frequencies and power available on request.

CHARACTERISTICS (continued)

F.M. noise Δf_{rms} at 100 kHz off carrier

typ. 0,15 Hz in a 1 Hz band

A.M. noise $\frac{P_{am}}{P_{carrier}}$ at 100 kHz off carrier

< -145 dBc in a 1 Hz band

MECHANICAL DATA

The oscillator base plate has four screw holes so that it can be secured to a heatsink. Output power is taken via a coaxial SMA female connector into a 50Ω load.

Outline drawing

Dimensions in mm

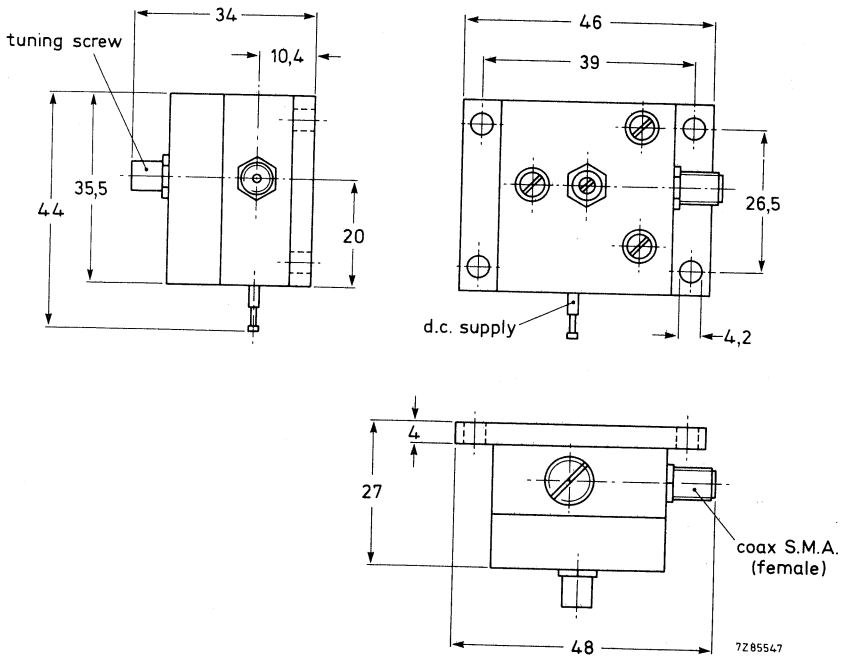

Fig. 1 Dielectric resonator stabilized Gunn oscillator.

OPERATING NOTES

1. Negative voltage must be applied to the soldering pin; the active element will be damaged if the supply voltage is reversed. The base plate is the common return for the Gunn diode voltage.
2. The power supply should be low-impedance voltage regulated and capable of supplying approximately 1,5 times the normal operating current to initiate oscillations. See Fig. 2.

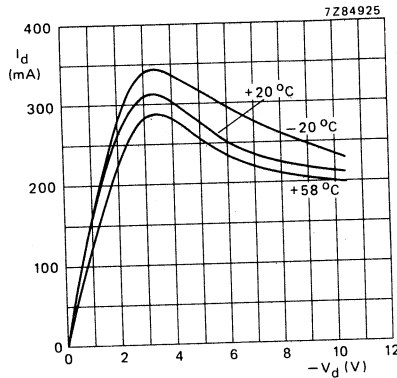

Fig. 2 D.C. bias characteristics of the Gunn oscillator for $T_{HS} = -20, +20$ and $+58$ °C.

3. It is recommended that a series R-C filter be connected in parallel with a voltage regulator diode across the oscillator supply voltage terminals. The filter prevents low-frequency bias supply oscillations, while the regulator diode protects the Gunn diode against transients. See Fig. 3.

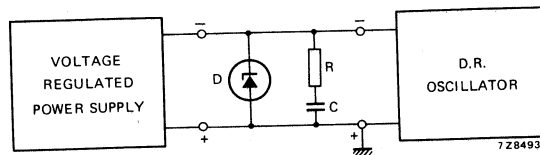

Fig. 3 Bias configuration for dielectric resonator stabilized Gunn oscillator.

D = voltage regulator diode, e.g. BZX70-C11

R = carbon resistor, 12 Ω .

C = film capacitor, 0,47 μ F.

OPERATING NOTES (continued)

4. A small screw on the top of the oscillator allows a limited range of tuning. Turning the screw clockwise, starting from the flush position of the internal pin ($\Delta f = 0$), increases the frequency. When tuning up to 0,5% (i.e. approx. $\Delta f = +50$ MHz), the stability of the oscillator remains unaffected; above that value the df/dT of the oscillator gradually increases due to Q-degradation of the dielectric resonator. A typical tuning curve is given in Fig. 4.

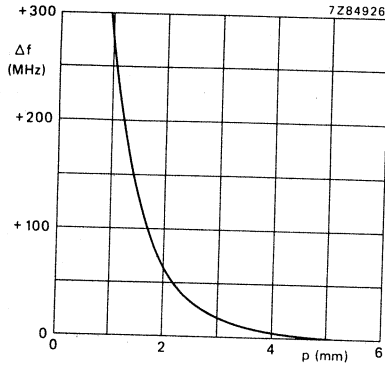

Fig. 4 Tuning of the oscillator as a function of the air gap between tuning screw and resonator: $f = f_0 + \Delta f$.

TYPICAL PERFORMANCE CURVES

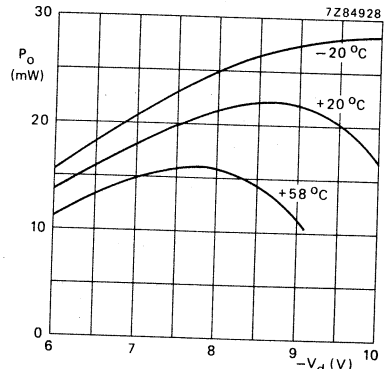
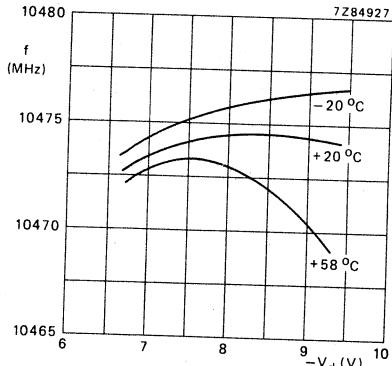

Fig. 5 Change of output power and frequency (pushing) with diode voltage for $T_{hs} = -20, +20$ and $+58^\circ\text{C}$.

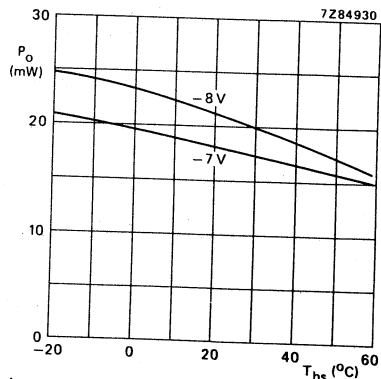
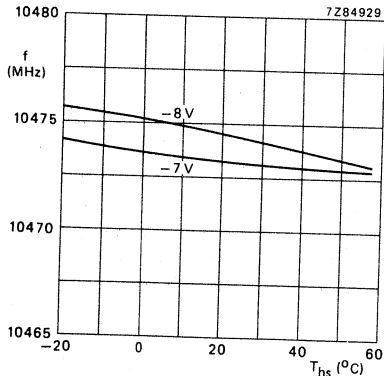

Fig. 6 Change of output power and frequency with heatsink temperature for $V_d = -7\text{V}$ and $V_d = -8\text{V}$.



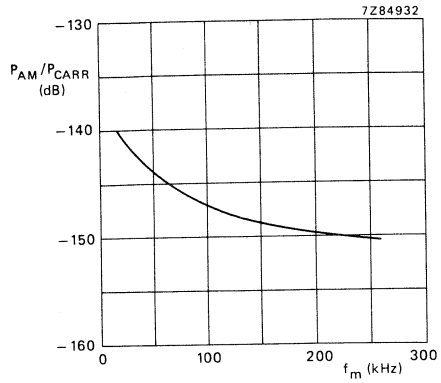
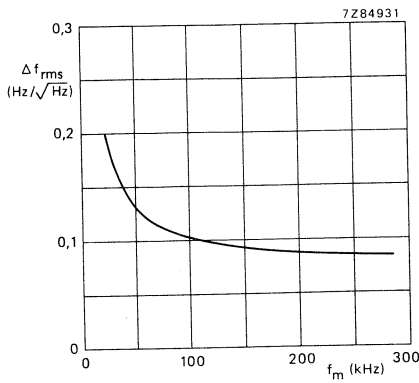

Fig. 7 Single-sideband a.m. and f.m. noise at $f_0 \approx 10,5$ GHz, measured in a bandwidth of 1 Hz at modulation frequencies f_m near to the carrier ($V_d = -8$ V).

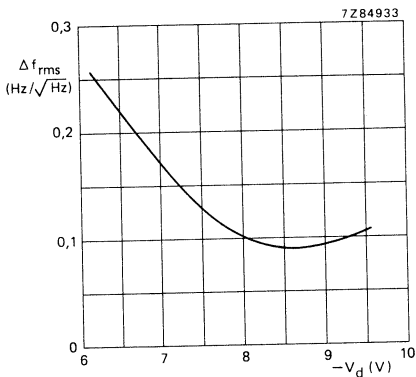

Fig. 8 Single-sideband f.m. noise at $f_0 \approx 10,5$ GHz, as a function of the diode voltage V_d , measured in a bandwidth of 1 Hz at 100 kHz distance from the carrier.

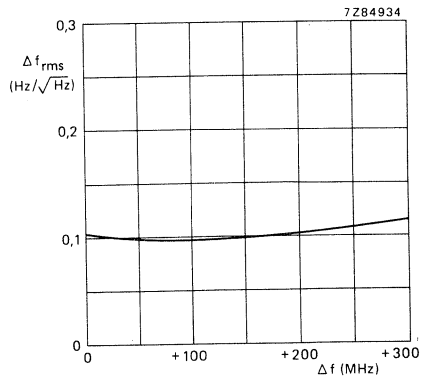

Fig. 9 Variation of the single-sideband f.m. noise at $f = f_0 + \Delta f$, with the tuning of the carrier frequency. Bandwidth = 1 Hz, $f_m = 100$ kHz, $V_d = -8$ V.

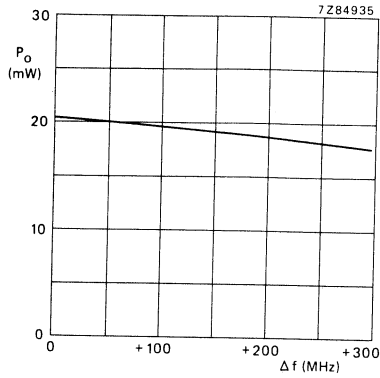

Fig. 10 Variation of the output power at $f = f_0 + \Delta f$ with frequency tuning Δf .
 $V_d = -8$ V, $T_{hs} = +25$ °C.

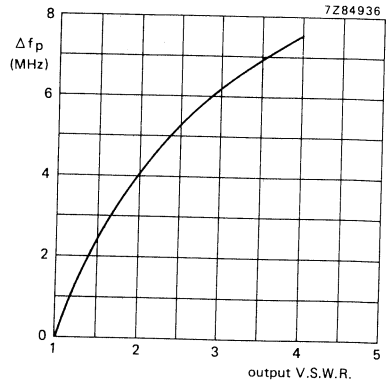
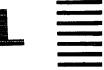

Fig. 11 Frequency pulling of the oscillator as a function of the output VSWR (all phases) for $f_0 \approx 10,5$ GHz, $P_O = 20$ mW, $V_d = -8$ V.



MIXER AND DETECTOR MODULES





L

X-BAND MIXER/DETECTOR MODULES

These are waveguide single ended mixers designed for use in the 9 to 11 GHz band. They are primarily intended for Doppler control systems, for example intruder alarms deriving local oscillator drive from the transmitter output of a Gunn oscillator from our CL8630 series.

These devices can be used as microwave detectors. Examples of this application are sensing deliberate beam obstruction in a microwave protected area and as a receiver in a microwave barrier or fence.

QUICK REFERENCE DATA

Centre frequency CL7500		10.687	GHz
CL7520		9.350	GHz
Sensitivity for -90 dBm input	typ.	40	μV ←
Noise level (32 μA d.c. bias, 1 Hz to 1 kHz bandwidth)	typ.	1.0	μV

This data must be read in conjunction with GENERAL SAFETY RECOMMENDATIONS – MICROWAVE SEMICONDUCTORS

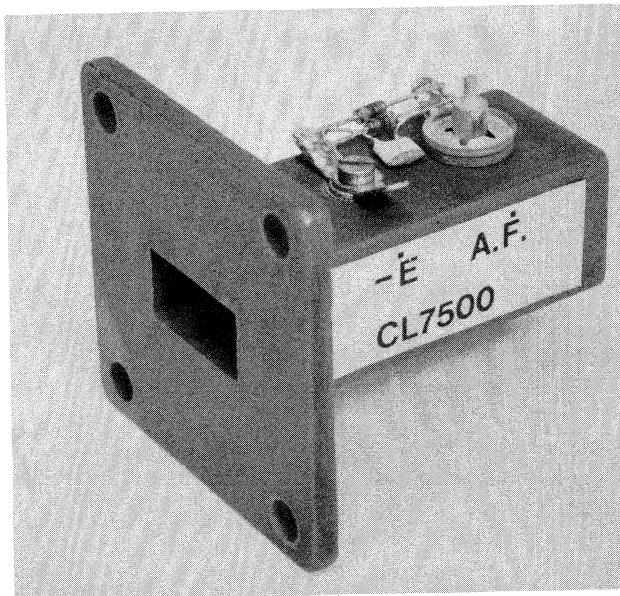

RATINGS

Limiting values in accordance with the Absolute Maximum System (IEC134)

Storage temperature range	T_{stg}	-10 to +100	°C
Ambient temperature range	T_{amb}	-10 to +50	°C

TYPICAL OPERATING CONDITIONS

Local oscillator level		-18	dBm
D.C. bias		32	μA
Total load (d.c. and i.f.)		10	$k\Omega$

CHARACTERISTICS ($T_{amb} = 25\text{ }^{\circ}C$)

		min.	typ.	max.	
Mixer					
→ Sensitivity for -90 dBm input (with a 10 $k\Omega$ load)		15	40	-	μV
Noise level (32 μA d.c. bias, 1 Hz to 1 kHz bandwidth) (note 1)		-	1.0	2.0	μV
Detector					
Tangential sensitivity at centre frequency (note 2)	S_{ts}	-	-50	-	dBm

Notes

1. When the local oscillator power is derived from a Gunn oscillator with an a.m. noise to carrier ratio of -94 dB (typically from our CL8630 series), the minimum sensitivity specified represents a signal to noise ratio at the mixer output of 18 dB (typically 24 dB).
2. When operated as a detector with 32 μA bias, measured in a 0 to 2 MHz bandwidth.
3. The module is supplied with a protection circuit connected between the mixer a.f. and earth terminals. The mixer has a low junction capacitance and may be damaged by transients of very short duration. It is therefore recommended that soldering irons are isolated from mains supplies and that the protection circuit is not removed when all wiring has been completed. Mixer and earth connections should be made direct to the appropriate terminals and not to the protection circuit tags.
4. Precautions similar to those required for CMOS devices are necessary, namely:
 - a) Earthed wrist straps should be worn.
 - b) Table tops or other working surfaces should be conductive and earthed.
 - c) Anti-static clothing should be worn.
 - d) No electrical testing should be carried out without specific, approved and written test procedures.
 - e) To prevent the development of damaging transient voltages, devices should not be inserted or removed from test fixtures with power applied.
5. Connections to be made to W.G.16 components.

MECHANICAL DATA

Dimensions in mm ←

CL7500

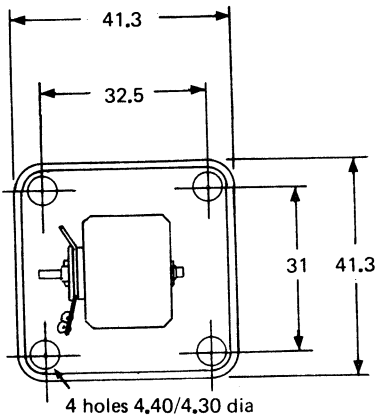
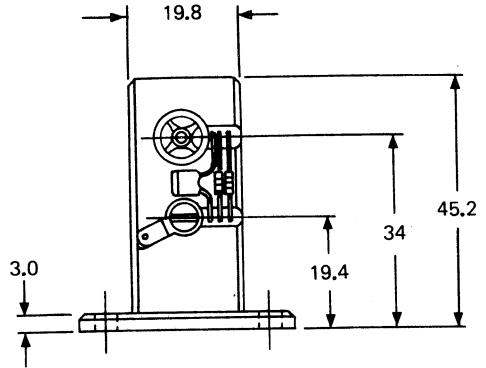
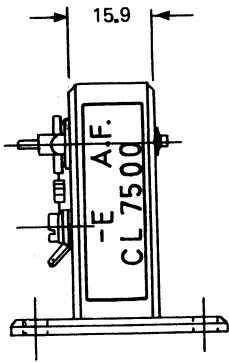

M81-1438/1

→ MECHANICAL DATA
CL7520

Dimensions in mm

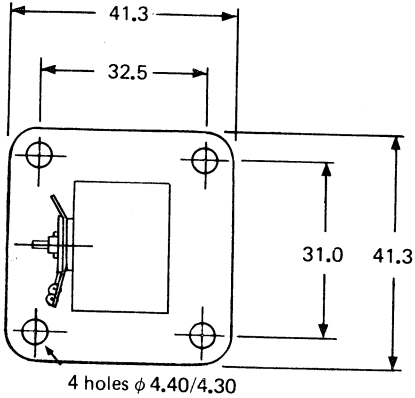
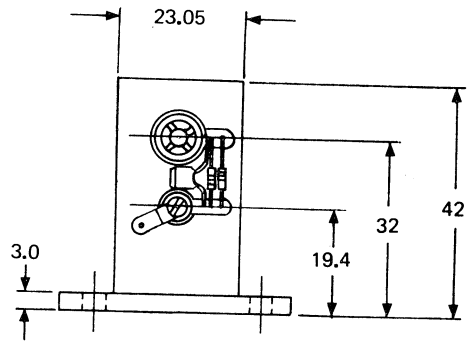
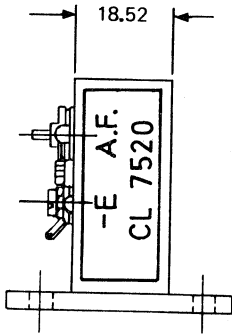

M81-1438/2

DOWN CONVERTER

Down converter for use in microwave radio link receivers in the various communication bands between 3,8 and 11,7 GHz. It consists of a balanced mixer with two Schottky barrier diodes, integrated isolator behind the r.f. input port, and a 70 or 140 MHz i.f. preamplifier. R.F. input is coaxial or waveguide (below 5,0 GHz coaxial only).

QUICK REFERENCE DATA

Frequency bands	3,8 to 11,7 GHz, see table
Noise figure	≤ 7 dB including isolator and preamplifier
Conversion gain	20 dB min.
Intermediate frequency	70 or 140 MHz
I.F. bandwidth	35 MHz

This data must be read in conjunction with GENERAL SAFETY RECOMMENDATIONS – MICROWAVE SEMICONDUCTORS

ELECTRICAL DATA

Frequency bands	3,8 to 4,0 GHz
	4,0 to 4,2 GHz
	4,4 to 4,7 GHz
	4,7 to 5,0 GHz
	5,4 to 5,9 GHz
	5,9 to 6,4 GHz
	6,4 to 7,2 GHz
	7,1 to 7,7 GHz
	8,0 to 8,5 GHz
	10,7 to 11,7 GHz

Transfer characteristics

Conversion gain	20 ± 2 dB, other values on request
Noise figure at 290 K	$\leq 7,0$ dB max.
Isolation between l.o. and r.f. input	≥ 30 dB
Flatness of i.f. output	$\pm 0,3$ dB

Power supply

Voltage	+ 12 V d.c. $\pm 10\%$, other values between + 10 and + 30 V on request
Maximum power	200 mW

R.F. input

Connector	50 Ω SMA or waveguide (below 5,0 GHz coaxial only)
Flange	IEC 154 UER70 or IEC 154 UBR100
Signal level	-20 dBm max.
V.S.W.R.	$\leq 1,2$

L.O. input

Connector

50 Ω SMA

Level

+ 20 dB m max.

V.S.W.R.

≤ 2

I.F. output

Intermediate frequency

70 MHz or 140 MHz

Bandwidth (-1 dB)

≥ 35 MHz

Connector

BNC

V.S.W.R.

≤ 1,25

Impedance

75 Ω

ENVIRONMENTAL DATA

Temperature range

0 to 50 °C

Humidity steady state

MIL-STD- 103B and C

Vibration

MIL-STD- 204C, cond. D

Mechanical shock

MIL-STD- 213B, cond. 1

Corrosion

MIL-STD- 101B, cond. B

MECHANICAL DATA

Outline

Dimensions in mm

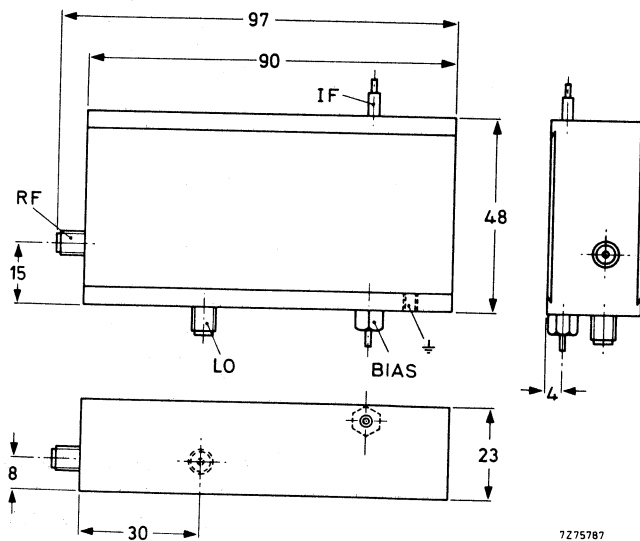

Fig. 1.

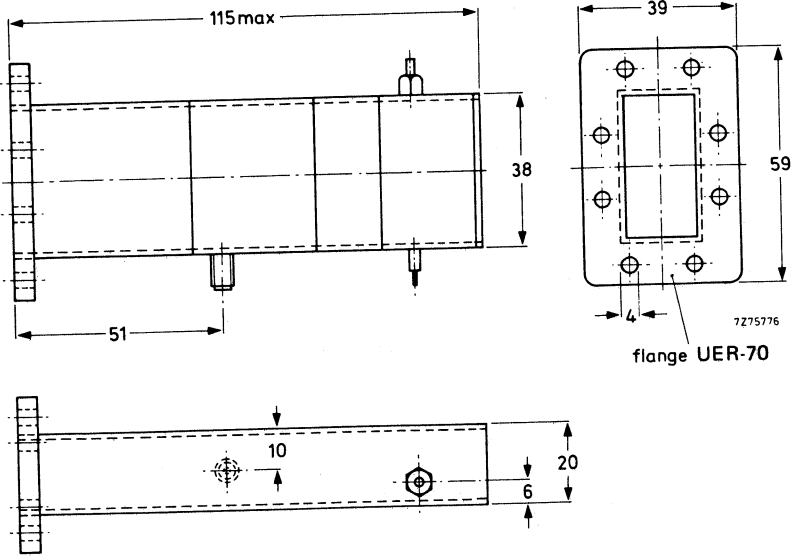
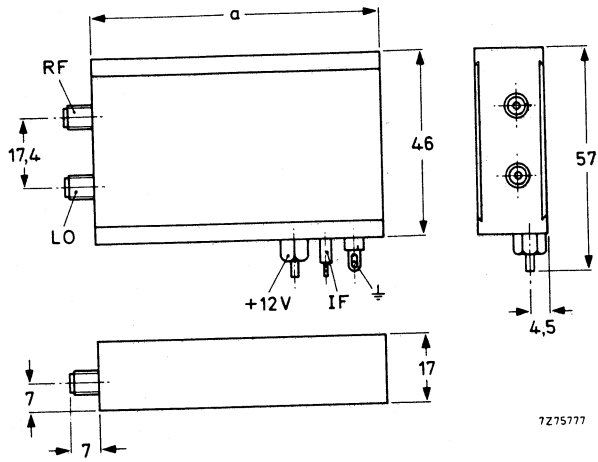

Fig. 3.

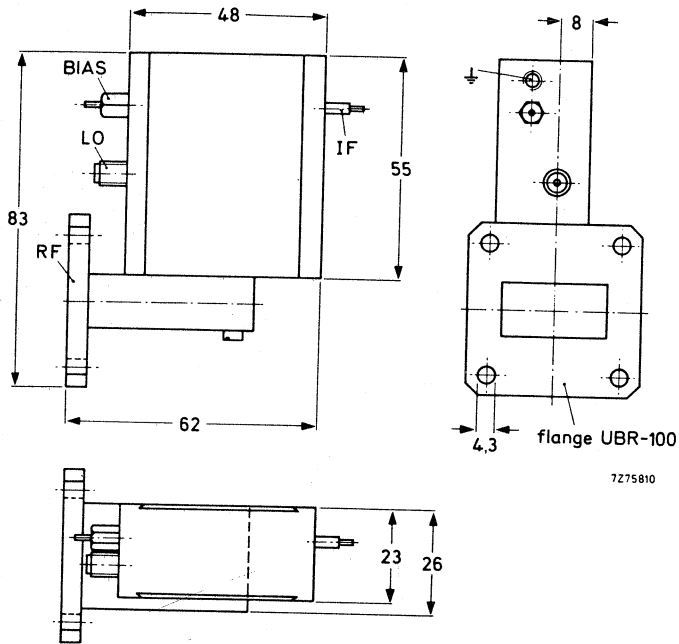

Fig. 4.

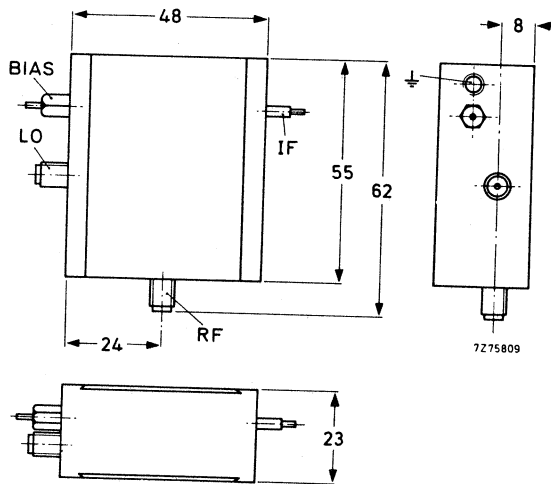

Fig. 5.

STANDARD TYPES

Frequency GHz	R.F. input	I.F. MHz	Figure	Type no.	Catalogue number
3,8 to 4,0	coaxial	70	1	JM1001	9360 015 40000
		140	1	JM1002	50000
4,0 to 4,2	coaxial	70	1	JM1003	60000
		140	1	JM1004	70000
4,4 to 4,7	coaxial	70	2a	JM1005	80000
		140	2a	JM1006	90000
4,7 to 5,0	coaxial	70	2a	JM1007	9360 016 00000
		140	2a	JM1008	10000
5,4 to 5,9	coaxial	70	2a	JM1009	20000
		140	2a	JM1010	30000
5,9 to 6,4	waveguide	70	3	JM1011	40000
		140	3	JM1012	50000
	coaxial	70	2b	JM1013	60000
		140	2b	JM1014	70000
6,4 to 7,2	waveguide	70	3	JM1015	80000
		140	3	JM1016	90000
	coaxial	70	2b	JM1017	9360 017 00000
		140	2b	JM1018	10000
7,1 to 7,7	waveguide	70	3	JM1019	20000
		140	3	JM1020	30000
	coaxial	70	2b	JM1021	40000
		140	2b	JM1022	50000
8,0 to 8,5	waveguide	70	3	JM1023	60000
		140	3	JM1024	70000
	coaxial	70	2b	JM1025	80000
		140	2b	JM1026	90000
10,7 to 11,7	waveguide	70	3	JM1027	9360 018 00000
		140	3	JM1028	10000
	coaxial	70	5	JM1029	20000
		140	5	JM1030	30000
10,7 to 11,7	coaxial	70	4	JM1031	40000
		140	4	JM1032	50000

DOPPLER MODULES AND VEHICLE DETECTORS





M

MICROWAVE VEHICLE DETECTORS

Fixed frequency microwave vehicle detectors with direction sense, for operation in the 10.6 GHz band using Doppler radar for vehicle actuated traffic signals. They comply with government regulations in the U.K. (D.o.E. specifications MCE0111, MCE0114 and MCG0500 and Home Office regulations BR14, 1975 specification). The CL8880BN has a rear cable entry and in the CL8880BNC the cable entry is via the mounting foot. The CL8882 is a 240 V a.c. version with separate signal and supply cables.

QUICK REFERENCE DATA

Centre frequency		10.587	GHz
Transmitted power	typ.	5	mW
Detection range for small vehicle moving at 50 km/h (30 m.p.h.) with detector mounted 2.5 m above typical road surface	typ.	100	m
Supply voltage (a.c.) centre tapped		110	V
Supply voltage (a.c.) CL8882 only		240	V

This data must be read in conjunction with GENERAL SAFETY RECOMMENDATIONS – MICROWAVE SEMICONDUCTORS

SAFETY PRECAUTION

The centre-tap of the 55–0–55 V supply is connected to the case and must be earthed.

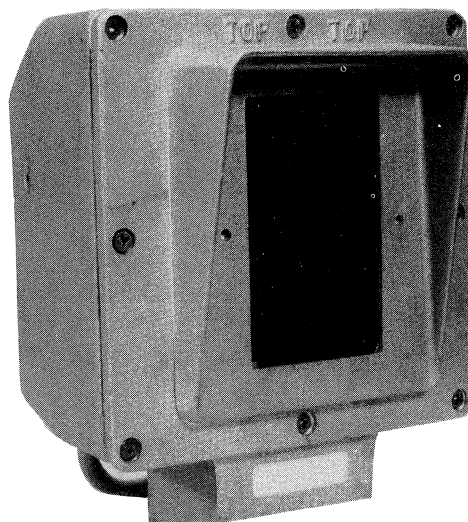

RATINGS

Limiting values in accordance with the Absolute Maximum System (IEC134)

Supply voltage (a.c.)	55–0–55 ± 20%	V
Supply voltage (a.c.) CL8882 only	240 ± 10%	V
Storage temperature range	–20 to +70	°C
Ambient operating temperature range	–15 to +50	°C

OPERATING CONDITIONS

Supply voltage (110 V _{ac} centre-tapped)	55–0–55	V
Supply voltage (a.c.) CL8882 only	240	V
→ Power consumption	typ. 12	W

CHARACTERISTICS

	min.	typ.	max.	
Centre frequency, fixed in the range	10.577	10.587	10.597	GHz
Transmitted power	–	5	10	mW
Detection range for vehicle moving at 50 km/h (30 m.p.h.) with the detector mounted 2.5 m above typical road surface	85	100	–	m
Mass	–	3	–	kg



OPERATING NOTES

1. The detector is of single-chassis construction.
2. It is recommended that the detector is mounted so that the centre of the microwave window (radome) is not less than 150 mm above the cowl of the red signal. There will then be minimal interruption of the beam by the cowl and the near-field performance of the detector will not be impaired.
3. In operation, the traffic signal controller demand input is connected to the 'relay output' terminals. In the standard unit, for use with portable signal heads, the relay is energized closed, except when a demand is present, (CL8880BN and CL8880BNC only).
4. CL8880BN and CL8880BNC units with 'normally open' relay connections are available on request.
5. A 47 Ω resistor in series with the relay output terminals is included for overcurrent and overvoltage protection.
6. Upon detection of oncoming traffic, the relay in the detector is de-energized and a pair of isolated contacts is opened to signify detection. The contacts remain open during the detection of a stream of oncoming traffic. The minimum open time is nominally 1 second, (CL8880BN and CL8880BNC only). A rear mounted red LED is illuminated during the detection period.
7. Signals caused by departing vehicles are ignored.
8. Should a fault occur in the detector or its supply voltage be interrupted, then the detector's relay will be permanently de-energized and a continuous demand will be applied to the controller. The traffic signals will then operate automatically in a fixed-time manner.
9. The power supply for the CL8880BN and CL8880BNC is derived from the main traffic control unit: a 55-0-55 V centre-tapped a.c. supply is necessary. This centre-tap is connected to the case and must be earthed.
10. The cable colour codes shown in table 1 and 2 must be observed.

TABLE 1 (CL8880BN, BNC)	
Cable colour codes	
Red	55 V _{ac}
Orange	55 V _{ac}
Black	0 V (centre tap of 110 V a.c. supply) earth
Green/Yellow	} Normally closed output contacts (isolated)
Green	

TABLE 2 (CL8882)			
Cable colour codes			
Supply cable	240 V a.c.	line	brown
		neutral	blue
		earth	green/yellow
Signal cable	green	} normally closed output contacts (opened when vehicle detected)	
	blue		
common	blue	} normally open output contacts (closed when vehicle detected)	
	red		

OPERATING NOTES (continued)

11. The equipment detects lone vehicles approaching the traffic signals in the presence of large departing vehicles or a heavy stream of departing traffic.
12. The equipment does not give false outputs in the absence of moving targets
13. Signals reflected from fluttering or waving trees at reasonable distances from the detector do not cause unwanted outputs, even if the detector is aimed directly at the trees.
14. For temporary traffic light systems, a 'NUDGE' facility is included.
15. The NUDGE facility is such that in the absence of a demand from approaching traffic for a period of 2½ minutes, a 'phantom' demand is applied. The relay in the detector is de-energized and the detector then returns to the vehicle-actuated mode. The period is set by a digital timer which is independent of the ambient temperature.
16. The 'phantom' demand overcomes the rare lock-up situations in traffic flow at temporary traffic lights where the possibility of a permanent 'red-red' can occur, caused by the non-detection of approaching vehicles.

SITE TESTS

1. To check the operation of a detector, set it up in the operating position with the power supplies connected and connect a multimeter, switched to a resistance-measuring range, across the normally-closed contacts. (Note: high-voltage circuit testers must not be used as they will damage the detector). The measured resistance should be approximately 47Ω ; this is the value of the protection resistor incorporated in the circuit.
2. Check the a.c. supply voltages at the microwave head. For the CL8880BN and BNC the line-to-line voltage should be $110 V_{rms}$ and the voltage between each line and the 0 V terminal should be $55 V_{rms}$; The tolerance on these voltages is $\pm 20\%$. For the CL8882 the supply voltage should be $240 V_{rms} \pm 10\%$.
3. Arrange for a vehicle, preferably a small car, to be driven towards and past the detector at approximately 50km/h (30 m.p.h.). When the car is between 150 and 100 metres approximately from the detector (see fig.2), the measured resistance between the normally-closed contacts should quickly increase to indicate an open-circuit. This condition should continue for approximately 1 second after the car has passed out of the detector's range.

WORKSHOP TESTS FOR INOPERATIVE SENSORS

1. These tests are intended to reveal inoperative detectors only. It must be noted that they do not replace any range tests carried out with a vehicle under site conditions.
There is no attempt to correlate range measurements with these tests as they will only inform the operator that a detector is functioning correctly, not functioning or is functioning in reverse. They will, however, ensure that there is some consistency of testing between different operators.
2. Ideally, the detector should be sited in an environment free, as far as possible, from extraneous movements of large bodies such as people, fork lift trucks, etc.



- The detector should be placed on a level surface, e.g. a bench, as near to the edge as possible to avoid reflections from the bench surface.

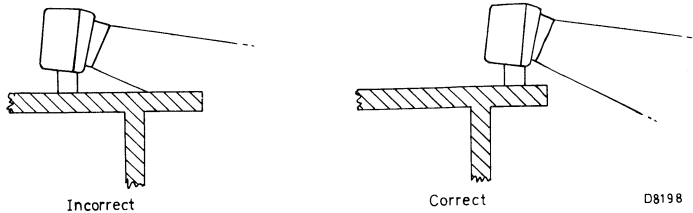

It should not be pointed directly at fluorescent lights as they may cause false demands to be registered, due to interference.

- Ensure that the environment is free as far as possible from microwave interference, for example, microwave vehicle detectors on soak test in the vicinity of the beam could cause interference giving rise to false demands.
- The supply cable/s should be connected in accordance with the codings given in table 1 and 2 on page 3.
- Demands may be observed by connecting the signal output leads (green and green/yellow) to a controller with a lamp which indicates presence of a demand. Alternatively, a bulb and power supply may be connected in series with the signal leads via a simple connector block of the push-button type. See diagram below.

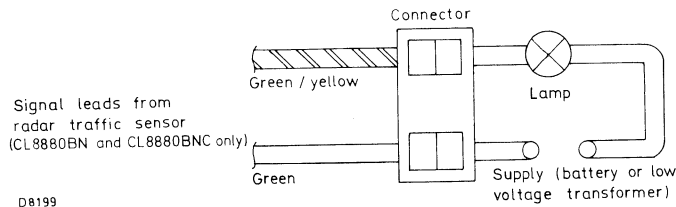

This simple method will eliminate the possibility of controller faults.

- With the supply connected and switched on, the indicator lamp should be illuminated.
- A demand will be indicated when the lamp is extinguished.
- Leave the detector pointing into free space and check for false demands. The lamp should remain alight for approximately 2 to 2½ minutes until the 'nudge' circuitry puts in a 'phantom' demand. These 'nudge' demands will reappear at regular intervals of 2 to 2½ minutes; no other demands should occur between them.
- With the detector placed on a level surface, (see note 3), about 1½ metres from ground level, the operator should stand about 5 metres away from the detector in a direct line with the microwave window (radome) and should have the demand indicator lamp in view. He should then walk at normal walking pace towards the detector, stopping at about 1 metre from it. If the detector is functioning correctly, a demand will be registered between starting to walk and stopping. He should then wait for the demand to clear and then walk backwards to his starting point. No demand should be registered. If a demand is observed, the detector is working in reverse and is therefore faulty.

CL8880BN
CL8880BNC
CL 8882

MECHANICAL DATA
CL8880BN

Dimensions in mm

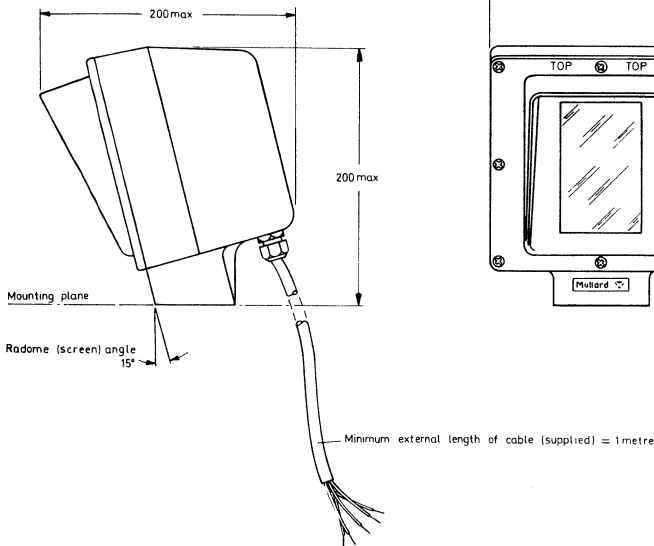
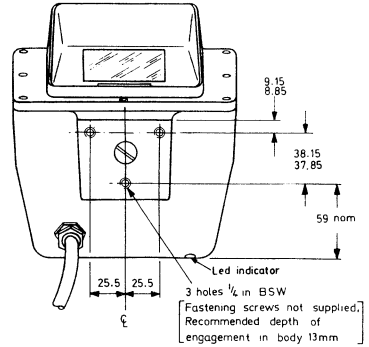

D8204b

MECHANICAL DATA
CL8880BNC

Dimensions in mm

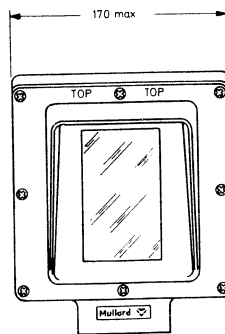
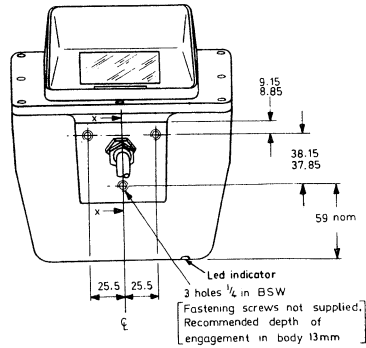
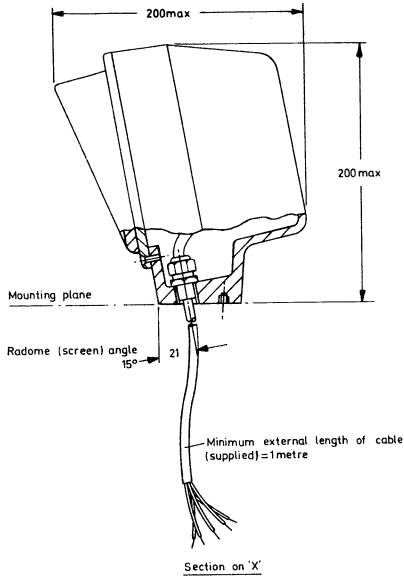

D8205b

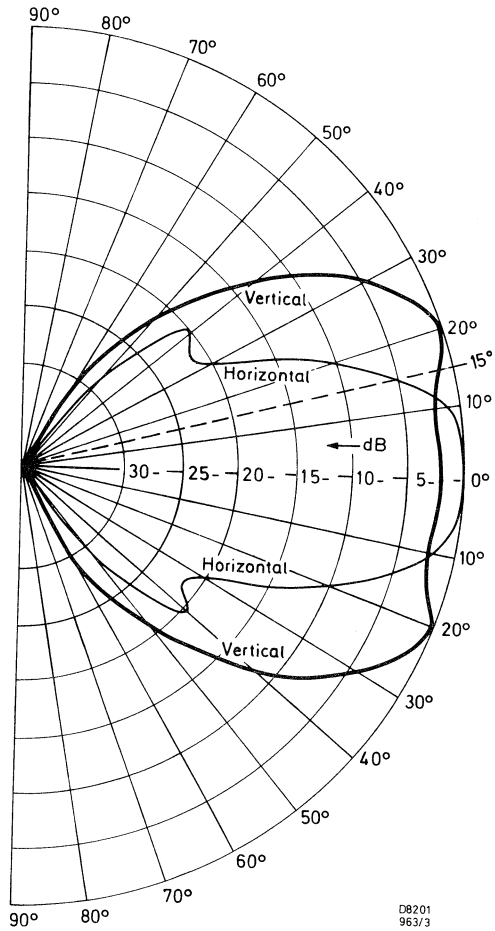

Fig.1 Typical polar diagram of microwave vehicle detector
The broken line indicates the preferred mounting angle of 15°. This affects only the orientation of the vertical pattern.

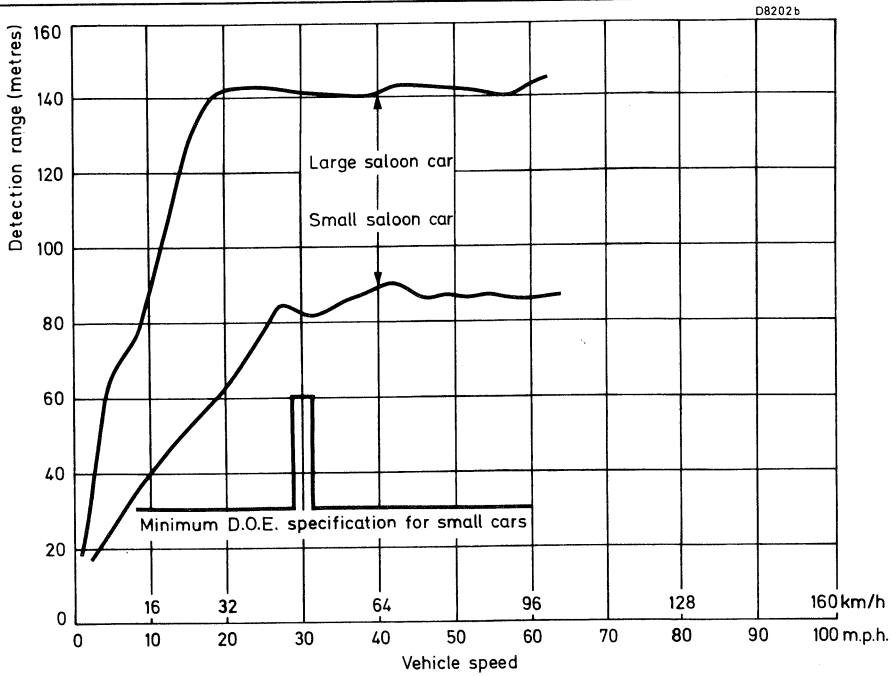

Fig.2 Typical detection curves obtained from road tests using six different microwave vehicle detectors.



X-BAND DOPPLER RADAR MODULES

This is a series of fixed frequency Gunn oscillators and mixer cavities for operation in X-band. Applications include all forms of Doppler radar systems.

QUICK REFERENCE DATA

Type No	Centre frequency GHz			
CL8960	10.687			
CL8961	9.350			
CL8962	9.470			
CL8963	10.525			
CL8964	9.900			
CL8965	10.565			
CL8967	10.365			
CL8968	9.520			
Supply voltage			+7.0	V
Power output (at 7.0 V)		typ.	10	mW
Voltage output for power input 100 dB down on power output at 18 dB min. <u>signal + noise</u> noise				
(note 1 and page 9)		typ.	40	μ V

This data must be read in conjunction with GENERAL SAFETY RECOMMENDATIONS – MICROWAVE SEMICONDUCTORS.

Module with antenna as supplied

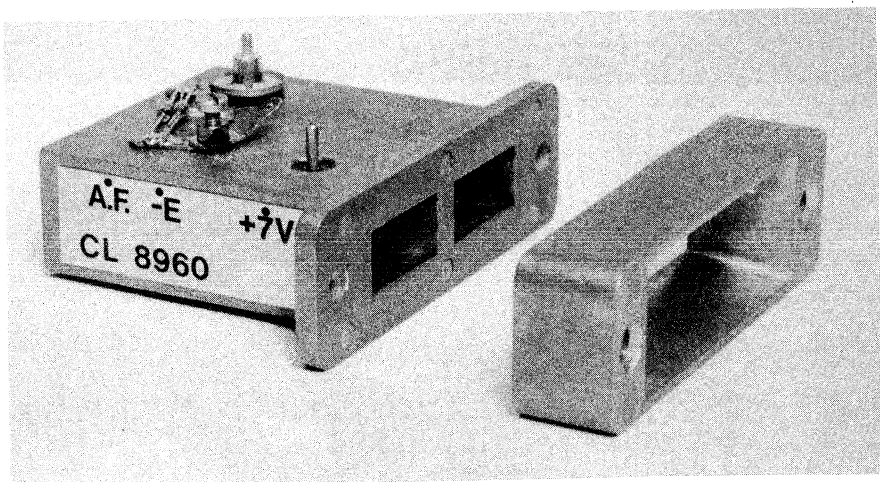

CL8960 SERIES

RATINGS

Limiting values in accordance with the Absolute Maximum System (IEC134)

Supply voltage (d.c.)	max.	+7.5 V
Supply voltage (for less than 1 ms)	max.	+9.0 V
→ Load v.s.w.r.	max.	1.5:1
Storage temperature range		-10 to +70 °C
Ambient temperature range		0 to +40 °C

OPERATING CONDITIONS

Supply voltage range (note 2)		6.8 to 7.2 V
Gunn operating current (note 3)	typ.	130 mA
D.C. mixer bias current (into a.f. terminal w.r.t. earth)		30 to 35 μ A
A.F. load (page 8)		10 k Ω

CHARACTERISTICS

	min.	typ.	max.	
Voltage output for power input 100 dB down on power output at 18 dB min. <u>signal + noise</u> noise (notes 1 and 4 and page 9)	20	40	—	μ V
Power output at 7.0 V	—	10	—	mW
Frequency temperature coefficient	—	-0.25	-0.40	MHz/°C
Frequency pushing	—	4.0	—	MHz/V
Gunn operating current (note 3)	—	130	165	mA
Polar diagram		page 10		
Centre frequency, fixed in the range:	CL8960 10.675	10.687	10.699	GHz
	CL8961 9.338	9.350	9.362	GHz
	CL8962 9.458	9.470	9.482	GHz
	CL8963 10.513	10.525	10.537	GHz
	CL8964 9.888	9.900	9.912	GHz
	CL8965 10.553	10.565	10.577	GHz
	CL8967 10.353	10.365	10.377	GHz
	CL8968 9.508	9.520	9.532	GHz

MASS

210 g

Alternative antennae and operating frequencies may be made to suit customers' specific requirements.

NOTES

1. A return signal 100 dB down on radiated power will be achieved from a man target of radar cross-section 1.0 m^2 at a range of 15 m, when operating with the antenna supplied (antenna gain is 5 dB typ.).

Extended range may be obtained for a reduced $\frac{\text{signal} + \text{noise}}{\text{noise}}$ and this may be acceptable if the

environment in which the system operates is stable, i.e. free from extraneous moving or vibrating objects. For example, 110 dB path loss is obtained from a man target of radar cross-section 1.0 m^2

at a range of 25 m and the $\frac{\text{signal} + \text{noise}}{\text{noise}}$ is reduced to 15 dB with an output voltage of $16 \mu\text{V}$ min.

Alternatively, the range may be increased by an increase in target radar cross-section or by the use of a high gain antenna. The performance may then be calculated from the radar range equation. Further related information may be obtained on application to the manufacturer.

2. It is essential that the earth terminal is used as the common return for the Gunn voltage (+7 V) and the d.c. bias supplied to the a.f. terminal. In addition, the soldered connection to the mixer should be made direct to the mixer terminal and not to the associated protection circuit.
3. The Gunn effect device has a voltage current characteristic as shown on page 8. The power supply should have a low source impedance and be capable of supplying up to 250 mA at approximately 3 V during the switch-on phase.
4. Noise measured at a frequency 1 Hz to 1 kHz from carrier.
5. The Gunn device will be damaged if the supply is reversed.
6. The module is supplied with a protection circuit connected between the mixer a.f. and earth terminals. The mixer has a low junction capacitance and may be damaged by transients of very short duration. It is therefore recommended that soldering irons are isolated from mains supplies and the protection circuit is not removed when all wiring has been completed. Mixer and earth connections should be made direct to the appropriate terminals and not the the protection circuit tags.
7. Precautions similar to those required for CMOS devices are necessary, namely:
 - (a) Earthed wrist straps should be worn.
 - (b) Table tops or other working surfaces should be conductive and earthed.
 - (c) Anti-static clothing should be worn.
 - (d) No electrical testing should be carried out without specific, approved and written test procedures.
 - (e) To prevent the development of damaging transient voltages, devices should not be inserted or removed from test fixtures with power applied.
8. The above conditions apply when operated into the antenna supplied with the module.
9. A 10 nF capacitor should be connected across and close to the +7 V and earth terminals to suppress parasitic oscillations in the power supply.
10. $\frac{\text{Signal} + \text{noise}}{\text{noise}}$ performance may be degraded if the antenna is covered by a radome of unsuitable construction. Page 12 describes the preferred arrangement.

CL8960 SERIES

MECHANICAL DATA

CL8960
CL8963
CL8965

Dimensions in mm

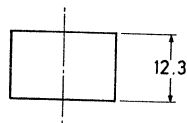
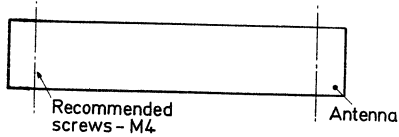
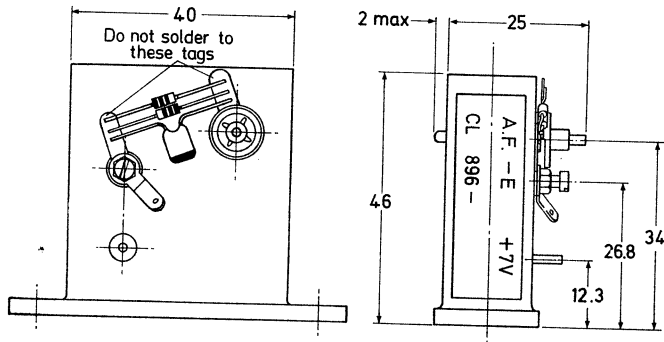
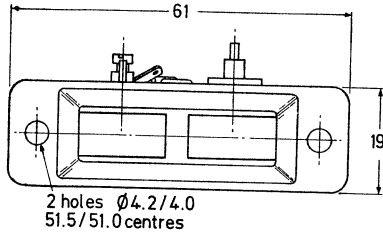

D6607C

MECHANICAL DATA

Dimensions in mm

CL8961
CL8962
CL8968

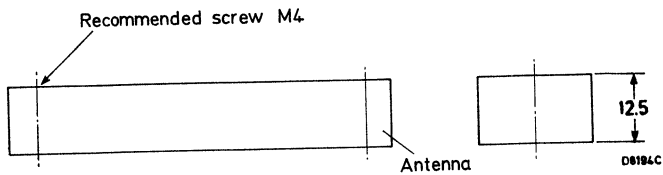
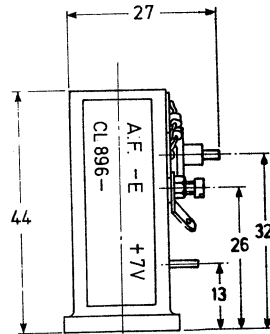
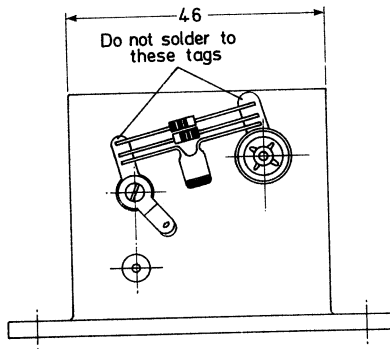
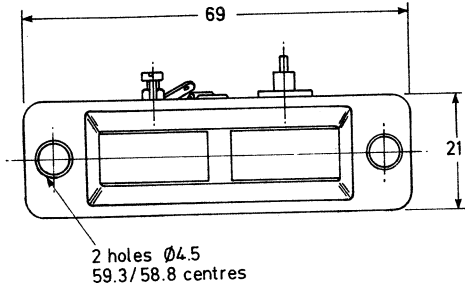

MECHANICAL DATA

CL8964

Dimensions in mm

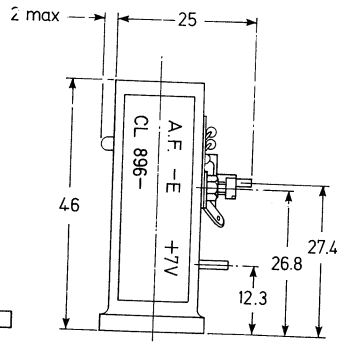
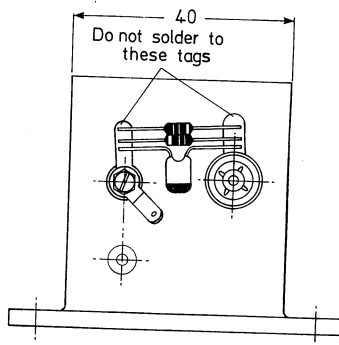
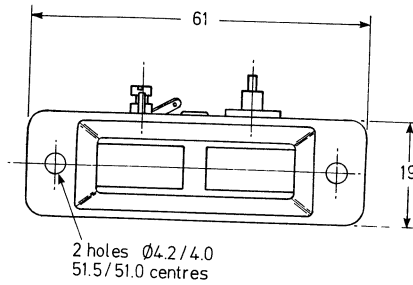

Recommended screws - M4.

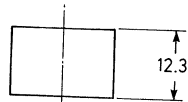
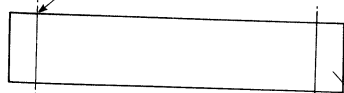

D8196B

MECHANICAL DATA

CL8967

Dimensions in mm

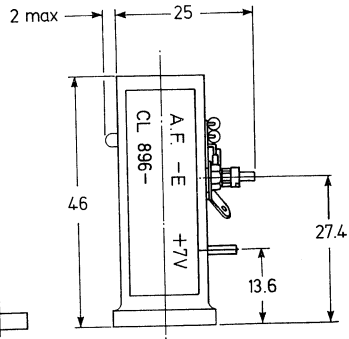
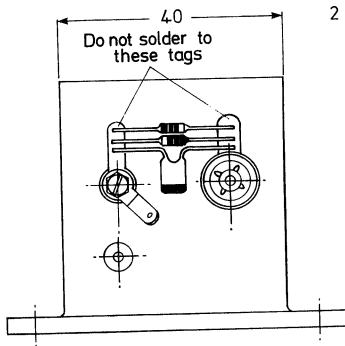
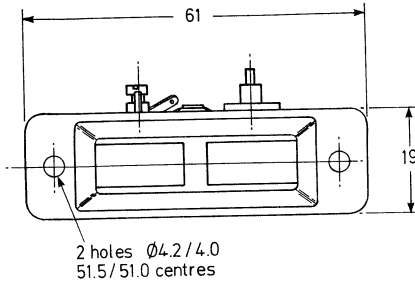

Recommended screws - M4

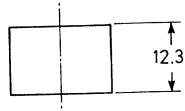
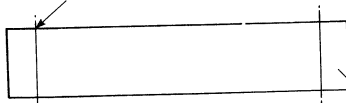

081978



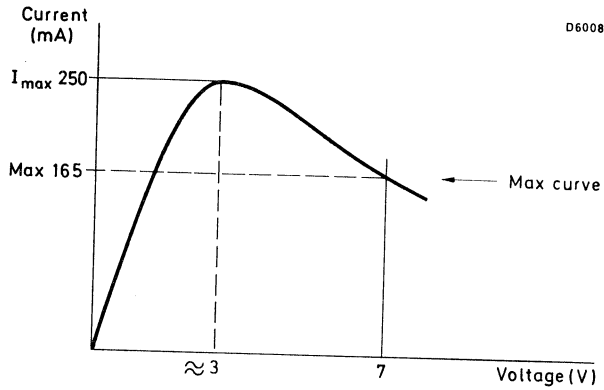

Typical Gunn device characteristic

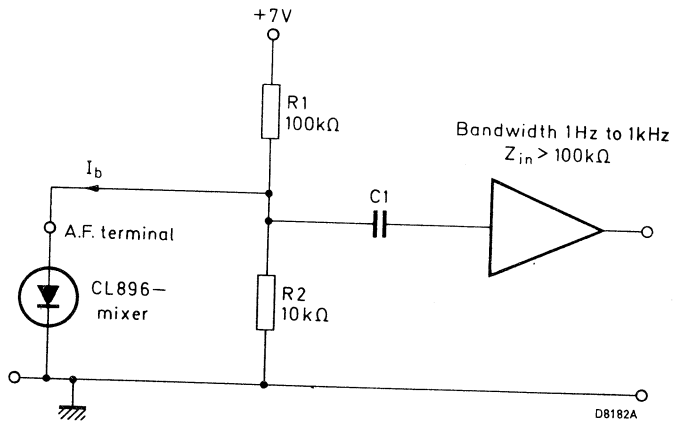

Circuit used to measure a.f. performance

Notes

1. The current I_b should be approximately $35 \mu A$ with the Gunn device disconnected and approximately $42 \mu A$ with the Gunn device operational and the antenna operating into free space.
2. The coupling capacitor should have a small impedance compared with Z_{in} .

D6010

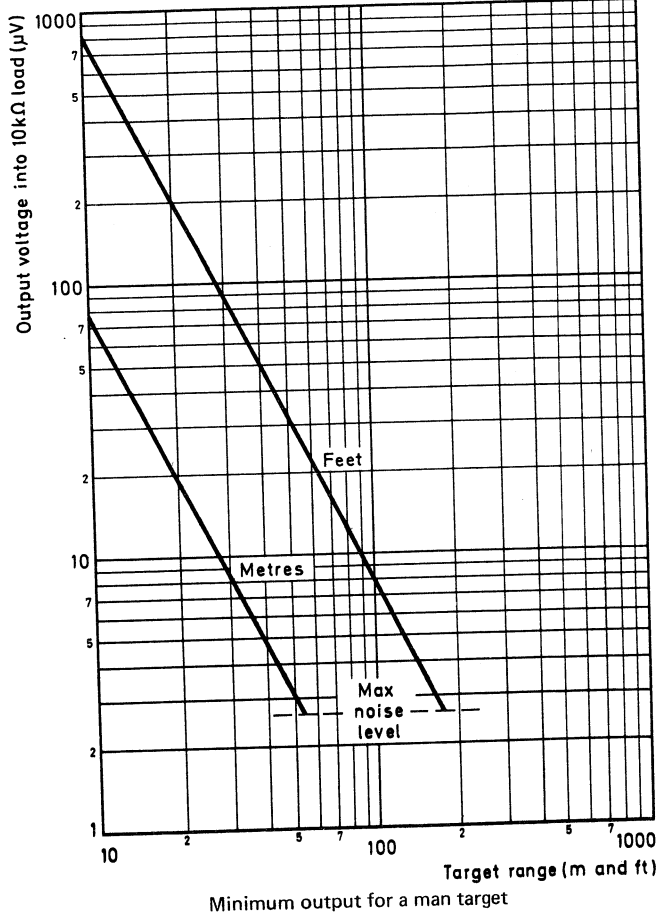

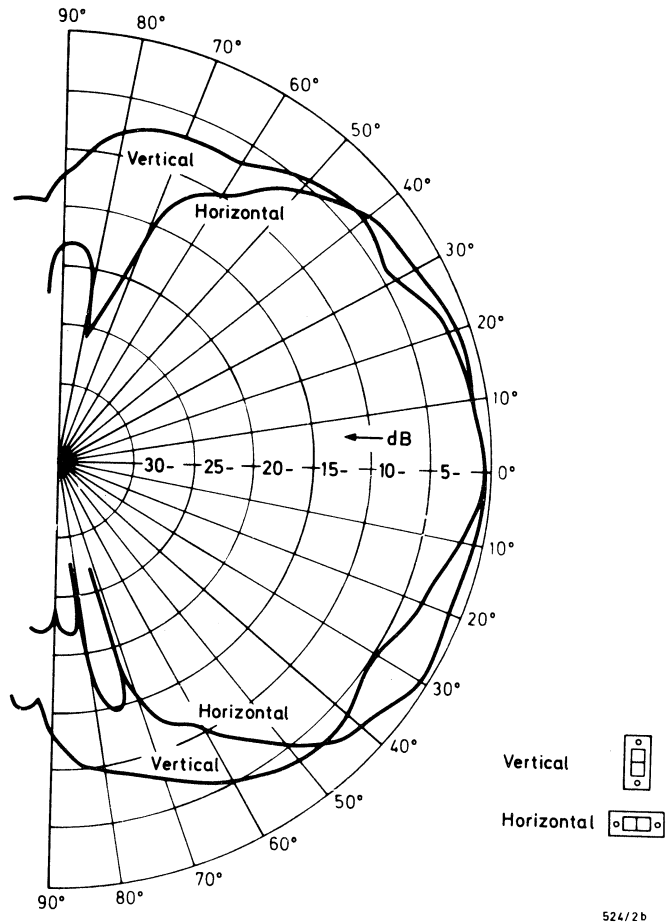

Typical polar diagram for antenna supplied



MODULE MOUNTING

For optimum signal to noise ratio, it is recommended that the module and antenna are mounted, using M4 screws, to a 1.6 mm thick metal plate with aperture dimensions as shown on page 12.

In this configuration, the metal plate forms the front panel of the equipment, and the antenna radiates into free space. If the equipment housing is all metal, any back radiation will be totally contained. Alternatively a metal based adhesive tape may be used to seal the joint between antenna and mounting plate.

The total mixer bias under the optimum operating conditions is approximately 42 μA . (35 μA d.c. bias + 7 μA from -19 dBm of coupled l.o. power).

If, however, for environmental reasons, it is considered desirable to cover the antenna aperture, then it is recommended that a thin plastic material (approximately 0.25 mm thick) is fixed to the metal plate with adhesive. A suitable plastic material is described below.

In this case, the l.o. power coupled to the mixer will be -11 dBm, and the total mixer bias current will now be approximately 60 μA .

The increase in l.o. power will, in general give rise to an increase in a.f. output voltage for a given target, but this will be accompanied by a degradation in signal to noise ratio. For -11 dBm of l.o. power, the degradation in signal to noise ratio should be acceptable for most applications. However, further increase in the level of coupled l.o. power arising from the use of thick or 'micro-wave' reflective covering materials, will:

- (a) continue to increase the a.f. output voltage from the mixer (N.B. the increase will not be the same for all modules) but at the same time, degrade the signal to noise ratio.
- (b) present a mismatch to the Gunn oscillator which may impair the switching and running performance and may 'pull' the frequency outside the allocated operating frequency band.

The following table compares the l.o. coupling level obtained for different covering materials at the antenna.

L.O. coupling (dBm)	Mixer total bias (μA)	Antenna covering material
-	35 (d.c. only)	-
-19	42	No covering
-15	50	1 to 2 cm expanded polythene or polystyrene
-11	61	0.25 mm Cobex plastic
-6	70	0.5 mm Cobex plastic

Cobex is a product of:

British Industrial Plastics,
Sheet and Film Division,
Brantham Works,
Brantham,
Manningtree,
Essex,
CO11 1NJ,
England.



PANEL MOUNTING DETAILS

Dimensions in mm

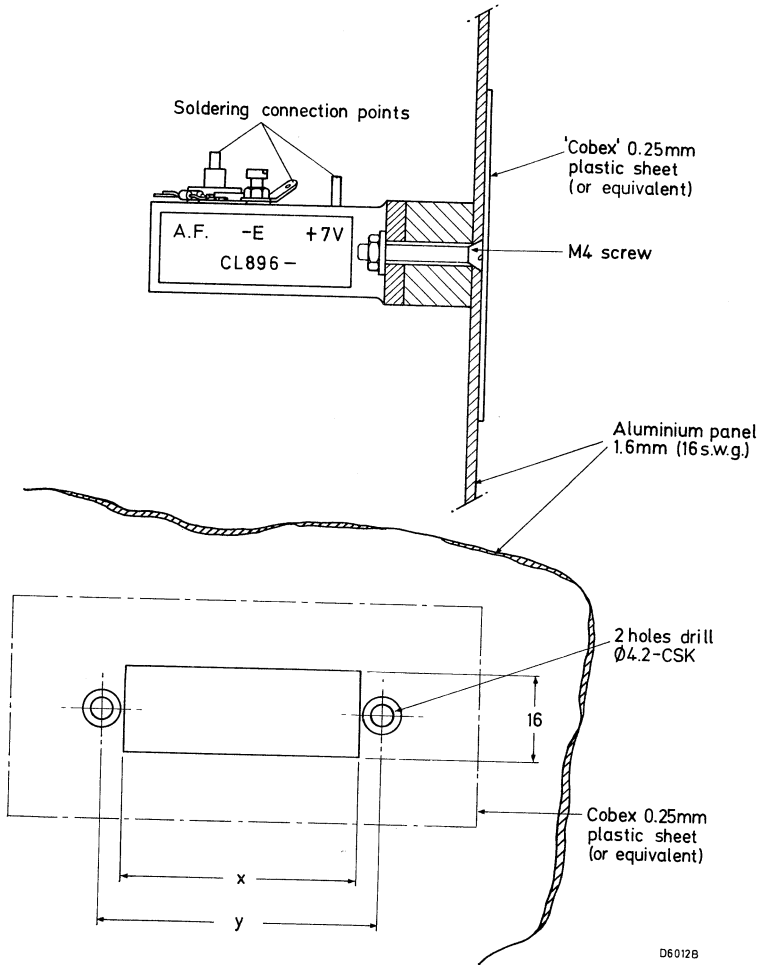

D60128

CL8960
 CL8963
 CL8964
 CL8965
 CL8967

$x = 43$
 $y = 51.5/51.0$

CL8961
 CL8962
 CL8968

$x = 50$
 $y = 59.3/58.8$

CIRCULATORS AND ISOLATORS

1. The first part of the document discusses the importance of maintaining accurate records of all transactions and activities. It emphasizes that this is crucial for ensuring transparency and accountability in the organization's operations.

||||| N

MICROSTRIP CIRCULATORS AND ISOLATORS

These components are designed on the basis of microstrip transmission lines of nominally 50Ω characteristic impedance. They are intended to be mounted between microstrip circuits where required.

The circulators consist of a ferrite substrate which supports a thin-film circulator pattern and ground plane. Two ticonal magnets mounted above and below the substrate provide the biasing magnetic field. For isolators the third port is terminated with a matched load.

To facilitate assembly between two adjacent circuits the units have a square or rectangular substrate, the edges of which are precision ground to fine tolerances. Assembly into the circuits should be carried out by bonding techniques or by pressure contacts. The use of soldering techniques for this purpose will result in the destruction of the component and/or degradation of its electrical performance. Some examples of suitable mounting techniques are given on pages 6 and 7.

The electrical characteristics are guaranteed when measured in our standard test jigs, which are available as standard accessories.

TERMS AND DEFINITIONS

Frequency range

This is the range within which the isolator or circulator meets the guaranteed specification.

Isolation

In an isolator, isolation is the ratio, expressed in dB, of the input power to the output power for signal injection in the reverse direction (matched source and load).

In a circulator, isolation is the ratio, expressed in dB, of the power entering a port to the power scattered into the adjacent port on the side opposed to the normal circulation (matched source and the other ports correctly terminated).

Insertion loss

This is the attenuation that results from including the device in the transmission system. It is given as a power ratio, expressed in dB, which compares the situation before and after the insertion of an isolator or circulator.

Maximum power

In an isolator, the maximum power is the highest power that may be passed through it (without damage) in the forward direction into a v.s.w.r. of 2. This power value must not be exceeded.

In a circulator, the maximum power is the highest power it can handle at sea level and at maximum ambient temperature when one port is terminated with a mismatch giving v.s.w.r. of 2, whilst the next port is matched with a v.s.w.r. of 1.2 or less. This power value must not be exceeded.

Temperature range

This is the ambient temperature range within which isolators and circulators function to specification. Circulators still function outside the temperature range but their electrical behaviour may be far outside the guaranteed specifications. Isolators can be stored at any temperature between -55 and $+125$ °C.

MICROSTRIP CIRCULATORS

Electrical data (as measured in the related test jig)

Maximum power (c.w.)

10 W

Storage temperature

-55 to + 125 °C

frequency range GHz	isolation		insertion loss		v.s.w.r.		operational temperature °C	catalogue number	related test jig
	min. dB	typ. dB	max. dB	typ. dB	max.	typ.			
1,7 to 1,9 1,9 to 2,1 2,1 to 2,3	20	22	0,5	0,30	1,25	1,15	-10 to +60	03161 03171 03181	00141
2,2 to 2,5	20	22	0,4	0,25	1,25	1,2	0 to +50	03001 03011 03041	00021 00031 00041
3 to 3,5	20	22	0,4	0,30	1,20	1,15	0 to +50		
3,6 to 4,2	20	25	0,4	0,25	1,20	1,1	-10 to 70		
4,4 to 5,0 4,7 to 5,2 5,9 to 6,5 6,4 to 7,1 7,1 to 7,7	20	25	0,4	0,20	1,20	1,1	-10 to 70	03051 03061 03071 03081 03091	00061
7,7 to 8,5	20	25	0,4	0,25	1,20	1,1	-10 to 70	03101	00081
8,5 to 9,6	20	25	0,4	0,25	1,20	1,1	-10 to 70	03111 03121 03131 03141	00101
8,0 to 10,4	20	22	0,4	0,25	1,25	1,15			
8,0 to 12,0	17	19	0,5	0,40	1,35	1,25			
9,0 to 11,5	20	22	0,4	0,25	1,25	1,15			
14,4 to 15,25	20	22	0,5	0,30	1,25	1,15	-10 to 70	03151	00121

CAUTIONARY NOTE

Isolators and circulators have magnetic fields that are carefully adjusted for optimum operation; they should not, therefore, be subjected to strong external magnetic fields.

NOTE ON ELECTRICAL PARAMETERS

Stated electrical parameters are valid only when measured on a test jig supplied by us.

ENVIRONMENTAL DATA

The circulators have been tested by our independent Quality Control department in accordance with the following specifications:

Die shear strength: max. force 120 g/mm² to MIL-STD-883B method 2019.1.

Moisture resistance: 40 °C, R.H. 90-95%, 10 days to IEC 68-2-3 (1969) Test Ca, damp heat steady state.

PACKING

The minimum packing quantity is 5 units in one box. This is also the minimum ordering quantity.

Mechanical data (dimensions in mm)

Tolerances $\pm 0,05$ mm unless otherwise stated.

a	b	c	d $\pm 0,2$	e	f max.	g $\pm 0,0025$	h max.	mass g
38,1	38,1	8	21	16,5	7	1,02		17
25,4 25,4 18,98	25,4 25,4 18,98	8 5,5 5	13 14 10	12 12 9,5	7	1,02		8 8 5
12,62	12,62	4	6,3	5,2	8 8 10 10 10	1,02		2 2 2,5 2,5 2,5
10,40	12,62	4,5	5,8	5,2	7	0,51		2
8,17	9,85	2,95 2,95 3,4 3,4	5 5 4,65 4,65	5,2 5,2 4,3 4,3	7	0,51		1,5
6,32	7,6	2,5	3,6	3	8	0,51		0,75

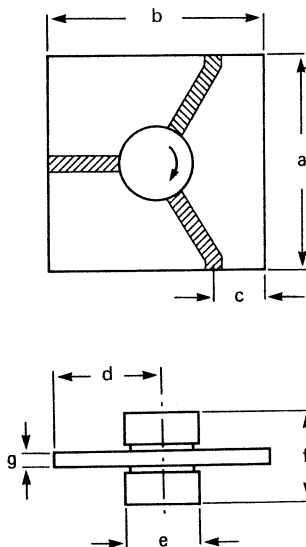

7Z89344

Fig. 1.

MICROSTRIP ISOLATORS

Electrical data (as measured in the related test jig)

Maximum power (c.w.) 10 W
 Maximum reverse power 100 mW
 Storage temperature -55 to +125 °C

frequency range GHz	isolation		insertion loss		v.s.w.r.		operational temperature °C	catalogue number	related test jig
	min. dB	typ. dB	max. dB	typ. dB	max.	typ.			
1,7 to 1,9 1,9 to 2,1 2,1 to 2,3	20	22	0,5	0,30	1,25	1,15	-10 to 60	01161 01171 01181	00151
2,2 to 2,5 3 to 3,5 3,6 to 4,2	20 20 20	22 22 25	0,4 0,4 0,4	0,25 0,30 0,25	1,25 1,20 1,20	1,2 1,15 1,1	0 to 50 0 to 50 -10 to 70	01191 01201 01041	00161 00171 00051
4,4 to 5,0 4,7 to 5,2 5,9 to 6,5 6,4 to 7,1 7,1 to 7,7	20	25	0,4	0,20	1,20	1,1	-10 to 70	01051 01061 01071 01081 01091	00071
7,7 to 8,5	20	25	0,4	0,25	1,20	1,1	-10 to 70	01101	00091
8,5 to 9,6 8,0 to 10,4 8,0 to 12,0 9,0 to 11,5	20 20 17 20	25 22 19 22	0,4 0,4 0,5 0,4	0,25 0,25 0,40 0,25	1,20 1,25 1,35 1,25	1,1 1,15 1,25 1,15	-10 to 70	01111 01121 01131 01141	00111
14,4 to 15,25	20	22	0,5	0,30	1,25	1,15	-10 to 70	01151	00131

Mechanical data (dimensions in mm)

Tolerances $\pm 0,05$ mm unless otherwise stated.

a	b	c	d $\pm 0,2$	e	f max.	g $\pm 0,0025$	h max.	mass g
38,1	38,1	8	21	16,5	7	1,02	1,7	17
25,4	25,4	8	13	12	7	1,02	1,7	8
25,4	25,4	5,5	14	12				8
18,98	18,98	5	10	9,5				5
12,62	12,62	4	6,3	5,2	8	1,02	1,7	2
					8			2
					10			2,5
					10			2,5
10,40	16,0	3,5	10,2	5,2	7	0,51	1,3	2
8,17	12,62	2,4	8,4	5,2	7	0,51	1,3	1,5
				5,2				
				4,3				
				4,3				
6,32	11,0	2,5	7,0	3	8	0,51	1,3	0,75

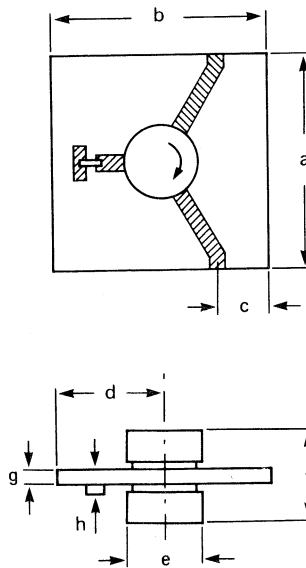

Fig. 2.

7Z89345

MOUNTING AND INTERCONNECTION IN MIC HOUSINGS

All devices are rectangular to facilitate insertion into associated circuitry.

Dimensions in mm

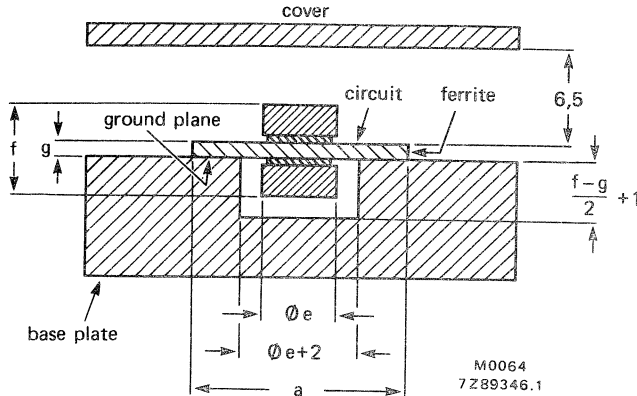

This figure gives the size of the recess in the base-plate and the height of the cover, assuming these parts are made of non-magnetic material. Increase these dimensions if magnetic material is used.

Fig. 3.

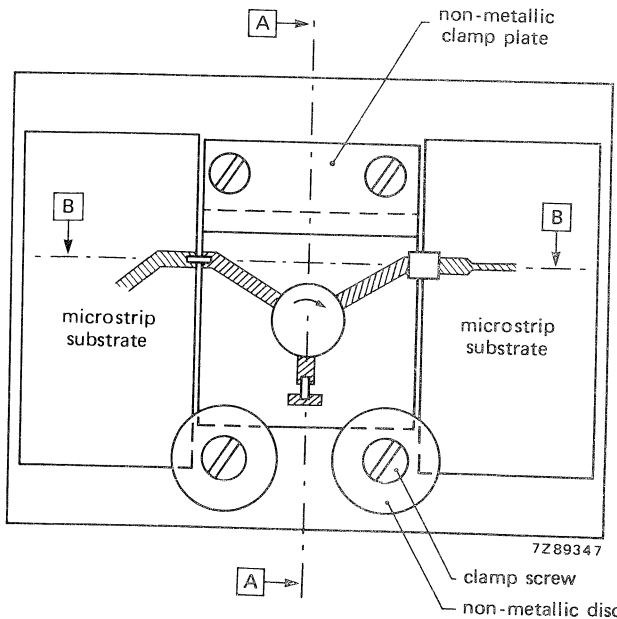

Two methods of mounting an isolator between MIC substrates:

- top: mounting the isolator independent of the MIC substrates using a non-metallic clamp-plate.
- bottom: clamping the isolator to the MIC substrates using non-metallic (e.g. nylon) discs.

The figure also shows two ways of making the electrical connections:

- left: gold beam bonding
- right: pressure contact.

Fig. 4.

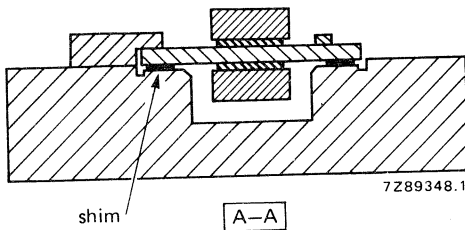

Fig. 5.

The cross-section through A-A (Fig. 4) shows again the clamp-plate mounting. The figure also shows how to obtain a good ground connection to the base plate by using a shim of ductile conducting material (such as indium). A shim provides other advantages too, notably:

- by choosing the proper thickness, it can be used to align the isolator (or circulator) surface with the adjacent MIC substrate surface
- its ductility reduces stresses within the substrates caused by differential expansion.
- it compensates for small surface irregularities in the base-plate.

A good ground contact can also be made using solder or conducting adhesives. These may introduce stresses, however, so they are not recommended. If the use of solder or adhesive cannot be avoided, use a low temperature process; i.e. for solder, 10 seconds at a maximum of 200 °C and for an adhesive, curing temperatures of less than 150 °C.

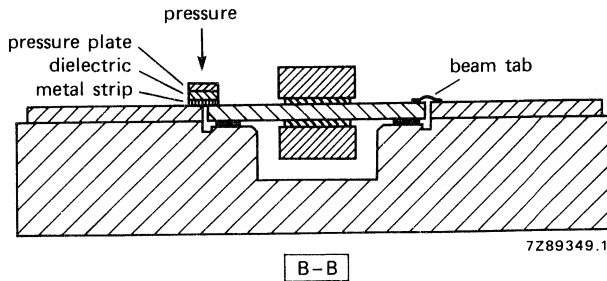

Fig. 6.

Cross section through B-B (Fig. 4) illustrating the connection techniques:

left: pressure contact

right: gold beam bond, which can be made ultrasonically or thermosonically, or by thermo-compression.

Careful milling is essential (rectangular and no burrs). Air gaps should be minimized but should not be less than 25 μm at room temperature.

Note: the linear expansion coefficient of ferrite is about $1 \times 10^{-5} / ^\circ\text{C}$.

ISOLATORS AND CIRCULATORS

Isolators and circulators are key elements in modern u.h.f. and microwave engineering. Their fundamental property of non-reciprocity is capable of simplifying the construction and improving the stability, efficiency and accuracy of radar, communication and testing systems.

The devices contain a core of ferrite material biased by a static magnetic field. This field orients the electron spins within the ferrite to produce a gyromagnetic effect. The non-reciprocal behaviour occurs when an r.f. signal, applied perpendicular to the biasing field, interacts with the precessing electrons to set up a standing-wave pattern within the core.

ISOLATORS

An isolator is a passive non-reciprocal 2-port device which permits r.f. energy to pass through it in one direction whilst absorbing energy in the reverse direction.

CIRCULATORS

A circulator is a passive non-reciprocal device with three or more ports. Energy introduced into one port is transferred to an adjacent port, the other ports being isolated. Although circulators can be made with any number of ports, the most commonly used are 3-port and 4-port ones, the symbols for which are given in Figs 1 and 2.

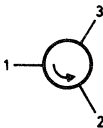

Fig. 1 Symbol for 3-port circulator.

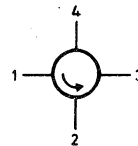

Fig. 2 Symbol for 4-port circulator.

Energy entering into port 1 emerges from port 2; energy entering into port 2 emerges from port 3, and so on in cyclic order.

TERMS AND DEFINITIONS

Frequency range

This is the range within which the isolator or circulator meets the guaranteed specification.

Isolation

In an isolator, isolation is the ratio, expressed in dB, of the input power to the output power for signal injection in the reverse direction (matched source and load).

In a circulator, isolation is the ratio, expressed in dB, of the power entering a port to the power scattered into the adjacent port on the side opposed to the normal circulation (matched source and the other ports correctly terminated).

Insertion loss

The attenuation that results from including the device in the transmission system. It is given as a power ratio, expressed in dB, which compares the situation before and after the insertion of an isolator or circulator.

Maximum power

In an isolator, the maximum power is the largest power that may be passed through it in the forward direction into a load with a v.s.w.r. of 2. This power value must not be exceeded.

In a circulator, the maximum power is the largest power it can handle at sea level and at maximum ambient temperature when one port is terminated with a mismatch giving a v.s.w.r. of 2, whilst the next port is matched with a v.s.w.r. of 1,2 or less. This power value must not be exceeded. If the mismatch of the load is expected to exceed a v.s.w.r. of 2, a circulator of higher power handling capacity should be used.

For coaxial circulators, the maximum power is the maximum continuous-wave power unless a maximum peak power is separately stated. This is the power as defined by the CCIR signal standard and is given for circulators at the v.h.f. and u.h.f. television frequencies. If this value is exceeded the circulator can be damaged by arcing in its internal transmission structure. Power values are valid for one signal passage only. If more than one signal passes through the circulator, the peak power of the combined signal should not exceed the indicated maximum peak sync power.

Temperature range

The ambient temperature range within which isolators and circulators function to specification. (When necessary, special temperature compensation is built in for circulators.) Circulators still function outside the temperature range but their electrical behaviour may then be far outside the guaranteed specifications. However, no permanent damage can be expected unless a large temperature rise is caused by excessive power handling.

The storage temperature of isolators may be from -40 to $+125$ °C unless otherwise specified in the data.



CAUTIONARY NOTE

Isolators and circulators have internal magnetic fields that are carefully adjusted for optimum operation, they should not, therefore, be subjected to strong external magnetic fields.

QUALITY GUARANTEE

Subject to the Conditions of Guarantee the Manufacturer guarantees that isolators/circulators supplied to the purchaser meet the specifications published in the Manufacturer's Data Handbook and are free from defects in material and workmanship.

Under this guarantee the Manufacturer will within one year from the date of shipment to the original purchaser, repair or replace at the Manufacturer's option, free of charge, any isolator/circulator proved by the Manufacturer's inspection to be thus defective.

STANDARD TEST SPECIFICATIONS**Initial measurements**

These measurements have been carried out at room temperature and at the extreme temperatures, with a power level not exceeding 10 mW.

Tropical test

This test has been carried out completely in accordance with IEC 68 test D, accelerated damp heat. This test begins with the temperature at 55 ± 2 °C and R.H. at 95 to 100% for a period of 16 hours, followed by a period of 8 hours with the temperature at + 25 °C and R.H. 80 to 100% to complete the 24-hour cycle: the test consists of 6 uninterrupted cycles.

Vibration test

This test has been carried out completely in accordance with MIL-STD-202D, method 201A: frequency range 10 to 55 to 10 Hz for 2 hours in each of the X, Y and Z directions, with a total excursion of 1,5 mm.

Thermal shock test

This test has been carried out completely in accordance with MIL-STD-202D, method 107C under condition A: 5 cycles with extreme temperatures of -55 °C and + 85 °C; each cycle of 1 hour's duration.

Mechanical shock test

This test has been carried out in accordance with MIL-STD-202D, method 213A under condition G: peak value 100 g, durations 6 ms, and also with extreme peak values up to 800 g, duration approximately 1 ms for each device, referring to the results of the drop test.

Drop test

This test has been carried out in accordance with ISO 2248, part IV: packaging complete, filled transport packages, vertical impact.

R.F. power test

The devices have been tested in accordance with the definition of maximum power in the Data Handbook (v.s.w.r. = 2). The ambient temperature of 25 °C was increased to the maximum operating temperature and the duration of the test was 1 hour for each device.

GENERAL

Final measurements

On completion of the above tests final measurements were carried out at a temperature of + 25 °C and with a power level not exceeding 10 mW. The results of these tests should be within the guaranteed values.

Dimensions and visual appearance

These have been checked in accordance with the published data.

Note

On request, different tests and/or additional tests to those above can be carried out.



APPLICATIONS

Symbols

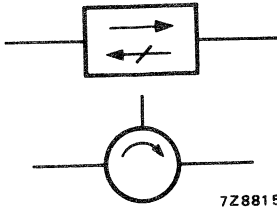

7Z88153

Decoupling of circuit stages

Isolator (or reflection-free terminated circulator)

Circulator

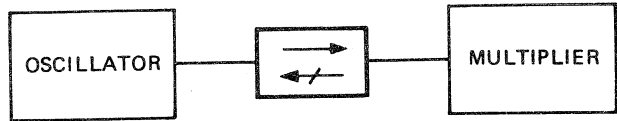
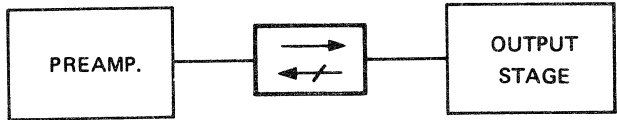

7Z88154

Reflection suppression in test chains

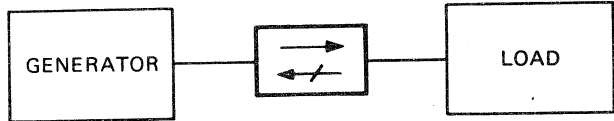

7Z88155

Suppression of reflections from

- long line to aerial
- mismatch by aerial damage
- feedback from nearby transmitters

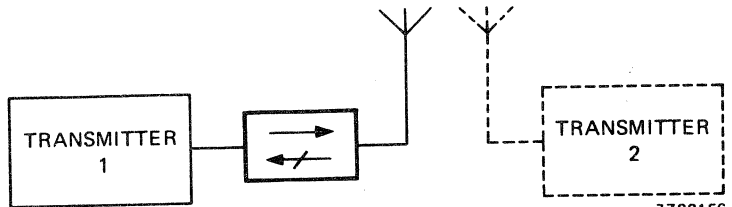

7Z88156

Separate input and output of a reflection amplifier, such as parametric amplifiers; tunnel, Gunn or Impatt diode amplifiers

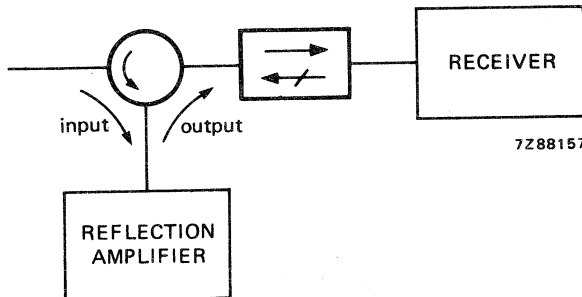

7Z88157

GENERAL

Feed trigger signals into an oscillator

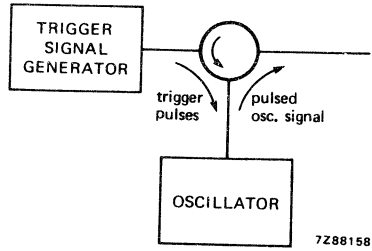

Avoid separate aerials for transmitter and receiver

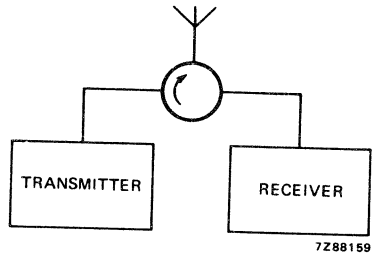

Connect different transmitters to a common aerial

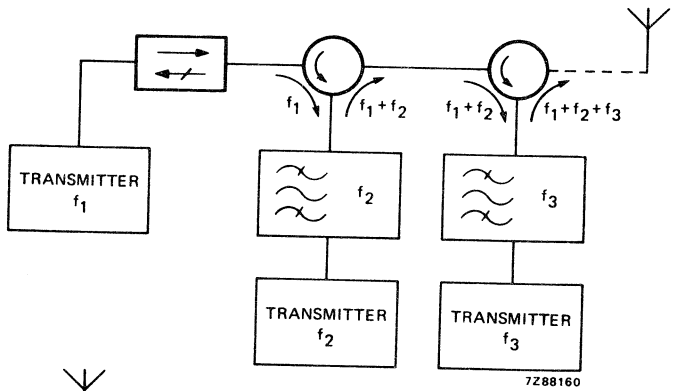

Separate a range of frequencies received by a common aerial

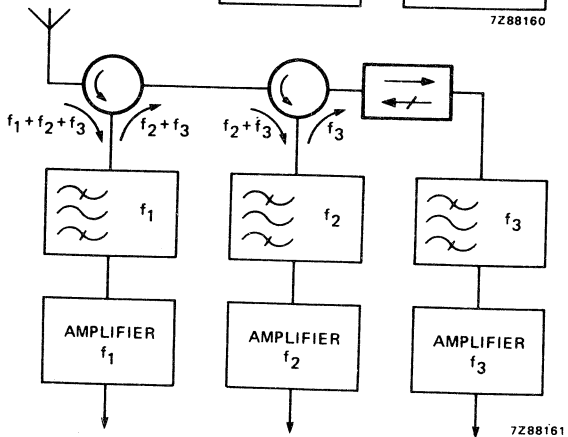

Signal combination and separation used together in a frequency-multiplexed, multichannel transceiver system

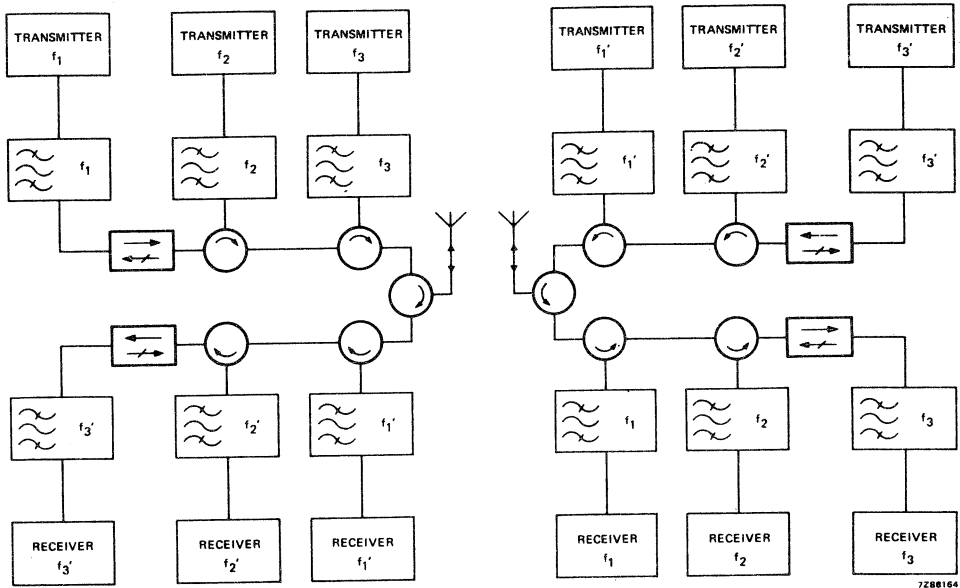

Variable phase shifters with a variable short-circuit

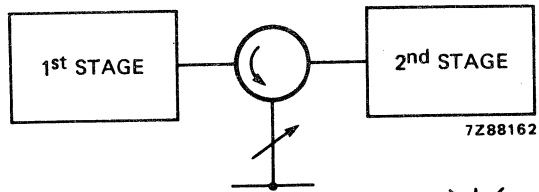

Phase modulation with a variable capacitance diode as a variable reactance

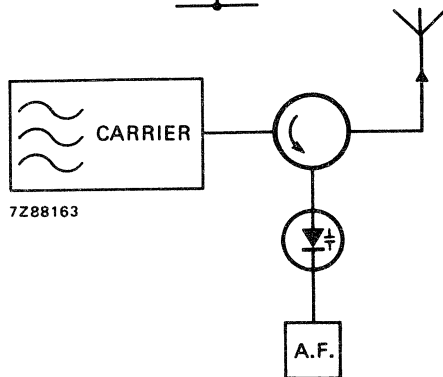

CATALOGUE NUMBER REFERENCE LIST

Waveguide types

catalogue number	frequency range (MHz)	application
2722 161 01101	4600 to 5000	micr. com.
01191	5925 6425	micr. com.
01211	8500 9600	X-band radar
01222	8500 9600	X-band radar
01231	6825 7425	micr. com.
01251	6425 7150	micr. com.
01261	8500 9600	X-band radar
01291	7125 7750	micr. com.
01361	8500 9600	X-band radar
01531	10025 10325	X-band radar
02071	8200 11200	micr. com.
02211	5925 6425	micr. com.
02232	3800 4200	micr. com.
02242	3400 3800	micr. com.
02252	3800 4200	micr. com.
02262	3400 3800	micr. com.
02311	6425 7150	micr. com.
02321	7125 7750	micr. com.
04001	5925 6425	micr. com.
04051	6425 7150	micr. com.
04061	7125 7750	micr. com.
2722 163 02004	2425 2475	ind. heating
02005	2425 2475	ind. heating
02024	2350 2400	ind. heating
02025	2350 2400	ind. heating

Coaxial types

catalogue number	frequency range (MHz)	application
2722 162 01121	470 to 600	TV IV/V
01131	590 720	TV IV/V
01141	710 860	TV IV/V
01261	470 600	TV IV/V
01271	710 860	TV IV/V
01281	590 720	TV IV/V
01331	600 800	TV IV/V
01491	2000 4000	gen. purp.
01501	2000 4000	gen. purp.
01511	3000 6000	gen. purp.

Coaxial types (continued)

catalogue number	frequency range (MHz)	application
2722 162 01551	470 to 600	TV IV/V
01555	462 468	mob./fixed com.
01561	600 800	TV IV/V
01572	400 470	mob./fixed com.
01582	470 600	TV IV/V
01592	590 720	TV IV/V
01601	600 800	TV IV/V
01612	710 860	TV IV/V
01632	470 600	TV IV/V
01642	590 720	TV IV/V
01651	600 800	TV IV/V
01662	710 860	TV IV/V
01811	4000 8000	gen. purp.
01822	7000 12400	gen. purp.
01851	200 230	TV III
01861	173 204	TV III
01871	160 178	mob./com.
01881	200 230	TV III
01891	173 204	TV III
01901	160 178	mob./com.
01931	225 270	mob./fixed com.
01941	270 330	mob./fixed com.
01951	330 400	mob./fixed com.
01981	710 860	TV IV/V
02071	3000 6000	gen. purp.
02091	2000 4000	gen. purp.
02101	2000 4000	gen. purp.
02111	4000 8000	gen. purp.
02122	7000 12400	gen. purp.
02221	12000 18000	gen. purp.
02231	7900 10200	gen. purp.
02471	4200 4400	navigation
02492	1427 1535	micr. com.
02501	8900 9600	micr. com.
02521	1470 1620	micr. com.
02531	1590 1800	micr. com.
02541	1760 1940	micr. com.
02551	1890 2110	micr. com.
02571	1700 2100	micr. com.
02581	1700 2100	micr. com.

Isolators and circulators

Coaxial types (continued)

catalogue number	frequency range (MHz)	application	catalogue number	frequency range (MHz)	application
2722 162 02591	1900 to 2300	micr. com.	2722 162 03831	156,9 to 162,1	mob./fixed com.
02601	1900 2300	micr. com.	03841	157,9 163,1	mob./fixed com.
02631	1470 1620	micr. com.	03851	165,4 170,6	mob./fixed com.
02641	1590 1800	micr. com.	03971	600 800	TV IV/V
02651	1760 1940	micr. com.	04031	3800 4200	micr. com.
02661	1890 2110	micr. com.	04041	4400 5000	micr. com.
02691	470 600	TV IV/V	04051	1700 2100	micr. com.
02701	600 800	TV IV/V	04061	1900 2300	micr. com.
02711	400 470	mob./fixed com.	05001	138 141	mob./fixed com.
02721	83 84	mob./fixed com.	05171	600 960	mob./fixed com.
02731	73 74	mob./fixed com.	06011	600 960	mob./fixed mob.
02741	790 1000	mob./fixed com.	Isoductors		
02751	600 800	TV IV/V	catalogue number	frequency range (MHz)	application
02851	460 468	mob./fixed com.	2722 162 09001	68 to 150	mob. com.
02861	86,5 87,5	mob./fixed com.	09011	140 260	mob. com.
02901	138 141	mob./fixed com.	09021	230 470	mob. com.
02911	72 73	mob./fixed com.			
02921	510 514	mob./fixed com.			
02931	406 414	mob./fixed com.			
02951	144,5 147,5	mob./fixed com.			
02961	153,5 156,5	mob./fixed com.			
02981	450 458	mob./fixed com.			
03001	470 600	TV IV/V			
03011	590 720	TV IV/V			
03141	470 600	TV IV/V			
03151	600 800	TV IV/V			
03171	225 270	mob./fixed com.			
03181	225 270	mob./fixed com.			
03191	600 800	TV IV/V			
03201	590 720	TV IV/V			
03211	710 860	TV IV/V			
03261	790 1000	TV IV/V			
03263	790 1000	mob./fixed com.			
03301	12000 18000	gen. purp.			
03371	463,2 466,8	mob./fixed com.			
03411	400 470	mob./fixed com.			
03421	270 330	mob./fixed com.			
03431	3800 4200	micr. com.			
03441	4400 5000	micr. com.			
03591	960 1225	navigation			
03722	225 400	mob./fixed com.			
03732	225 400	mob./fixed com.			
03802	1427 1535	micr. com.			
03811	790 1000	mob. com.			
03821	600 800	TV IV/V			

MOBILE & FIXED RADIO COMMUNICATION: COAXIAL

frequency range (1,3) MHz	circulator (c) isolator (i)	max. c.w. power		catalogue number	isolation	
		forw. W	refl. W		min. dB	typ. dB
72-73	i	25	20	2722 162 02911	20	23
73-74	i	25	20	02731	20	23
83-84	i	25	20	02721	20	23
86,5-87,5	i	25	20	02861	20	23
138-141	i	25	20	02901	22	24
	c	110		05001	22	24
144,5-147,5	i	25	20	02951	22	24
153,5-156,5	i	25	20	02961	22	24
156,9-162,1	c	110		03831	22	24
157,9-163,1	c	110		03841	22	24
165,4-170,6	c	110		03851	22	24
160-178	c	500		01871	20	24
	c	1000		01901	20	24
225-400	c	60		03732	16	19
	c	60		03722	16	19
225-270	c	150		01931	18	21
	c	500		03171	20	24
	c	1000		03181	20	24
	c	60		03421	18	21
270-330	c	150		01941	18	21
	c	150		01951	18	21
330-400	c	150		01951	18	21
	i	25	20	02711	20	25
	c	100		03411	20	25
406-414	c	300		01572	20	25
	ic (4)	70	70	02931	45	55
	ic (4)	70	70	02981	45	55
450-458	ic (4)	70	70	02981	45	55
460-468	ic (4)	70	70	02851	45	55
462-468	c	60	60	01555	25	30
510-514	ic (4)	70	70	02921	45	55
600-960	c	10		05171	16	20
	i	10	1	06011	16	20
790-1000	c	100		03811	20	25
	i	50	10	02741	20	25
	c	100		03261	20	25
	c	100		03263 (5)	20	25

Notes

1. Other frequency ranges and other connectors are available on request.
2. If the devices are air cooled, dry-air should be used at a pressure of 250 Pa and with a maximum intake temperature of 40 °C. The connector temperature should then not exceed 55 °C.
3. For tunable devices see "ISODUCTORS".
4. "ic" denotes a 4-port device with one port terminated with a matched load.
5. Type 2722 162 03263 is an ultra-low-noise version of type 2722 162 03261.
6. Types 2722 162 05171 and 2722 162 06011 are 34 ± 1 mm thick.

Isolators and circulators

insertion loss		v.s.w.r.		temperature range °C	connector type (1)	dimensions see Fig. no.	mass approx. g
max. dB	typ. dB	max.	typ.				
0,7	0,6	1,25	1,2	0 to 55	Nfem	C17	350
0,7	0,6	1,25	1,2	0 to 55	Nfem	C17	350
0,7	0,6	1,25	1,2	0 to 55	Nfem	C17	350
0,7	0,6	1,25	1,2	0 to 55	Nfem	C17	350
0,4	0,3	1,2	1,15	0 to 55	Nfem	C17	350
0,4	0,3	1,2	1,15	0 to 55	Nfem	C14	350
0,4	0,3	1,2	1,15	0 to 55	Nfem	C17	350
0,4	0,3	1,2	1,15	0 to 55	Nfem	C17	350
0,4	0,3	1,2	1,15	0 to 55	Nfem	C14	350
0,4	0,3	1,2	1,15	0 to 55	Nfem	C14	350
0,4	0,3	1,2	1,15	0 to 55	Nfem	C14	350
0,4	0,3	1,2	1,15	0 to 55	Nfem	C14	350
0,35	0,3	1,25	1,15	-10 to 60	Nfem	C1	2100
0,35	0,3	1,25	1,15	-10 to 40 (2)	HF7/16fem	C3	2150
1,4	0,9	1,5	1,3	-40 to 80	Nfem	C8	400
1,4	0,9	1,5	1,3	-40 to 80	SMAfem	C9	380
0,35	0,2	1,35	1,25	0 to 70	Nfem	C6	725
0,35	0,3	1,25	1,15	-10 to 60	Nfem	C1	2100
0,35	0,3	1,25	1,15	-10 to 40 (2)	HF7/16fem	C3	2150
0,35	0,2	1,35	1,25	0 to 70	SMAfem	C7	725
0,35	0,2	1,35	1,25	0 to 70	Nfem	C6	725
0,35	0,3	1,35	1,25	0 to 70	Nfem	C6	725
0,5	0,35	1,25	1,15	-10 to 60	Nfem	C17	350
0,5	0,35	1,25	1,15	-10 to 60	Nfem	C14	400
0,35	0,20	1,25	1,15	-10 to 60	Nfem	C4	1200
0,8	0,5	1,25	1,2	-10 to 60	Nfem	C19	800
0,8	0,5	1,25	1,2	-10 to 60	Nfem	C19	800
0,8	0,5	1,25	1,2	-10 to 60	Nfem	C19	800
0,5	0,3	1,2	1,1	-10 to 60	Nfem	C14	400
0,8	0,5	1,25	1,2	-10 to 60	Nfem	C19	800
1,3	0,8	1,4	1,25	-25 to 65	SMAfem	C16 (6)	400
1,3	0,8	1,4	1,25	-25 to 65	SMAfem	C18 (6)	400
0,5	0,3	1,25	1,14	-10 to 60	SMAfem	C16	400
0,5	0,35	1,25	1,15	-25 to 65	SMAfem	C18	400
0,5	0,3	1,25	1,14	-10 to 60	Nfem	C14	400
0,5	0,3	1,25	1,14	-10 to 60	Nfem	C14	400

TELEVISION

frequency range MHz	circulator (c) isolator (i)	max. forward power		catalogue number	isolation	
		c.w. W	peak W		min. dB	typ. dB
Band III						
173-204	c	500	1800	2722 162 01861	20	24
	c	1000	1800		01891	20
200-230	c	500	1800	01851	20	24
	c	1000	1800	01881	20	24
Bands IV and V						
470-600	i	10	20	02691	20	25
	c	100	200	01551	20	25
	c	300	500	01582	20	25
	c	300	500	01632	20	25
	c	500	900	01121	22	24
	c	500	900	03141	20	24
	c	2000	2000	01261	20	24
	c	2000	8000	03001	20	25
600-800	i	10	20	02701	20	25
	i	10	20	02751	20	25
	c	50	100	03821	20	25
	c	100	200	01561	20	25
	c	100	200	03971	20	25
	c	300	500	01601	20	25
	c	300	500	01651	20	25
	c	500	900	03191	22	24
	c	500	900	03151	20	24
	c	2000	2000	01331	20	24
590-720	c	300	500	01592	20	25
	c	300	500	01642	20	25
	c	500	900	01131	22	24
	c	500	900	03201	20	24
	c	2000	2000	01281	22	27
	c	2000	8000	03011	20	25
710-860	c	300	500	01612	20	25
	c	300	500	01662	20	25
	c	500	900	01141	22	24
	c	500	900	03211	20	24
	c	2000	2000	01271	22	26
	c	2000	8000	01981	20	25
790-1000	c	100	200	03261	20	25

Notes for TV band III

1. EIA 7/8-inch connectors can be provided on request.
2. If the devices are air cooled, dry-air should be used at a pressure of 250 Pa and with a maximum intake temperature of 40 °C. The connector temperature should then not exceed 55 °C.

Isolators and circulators

insertion loss		v.s.w.r.		temperature range °C	connector type (1)	dimensions see Fig. no.	mass approx. g
max. dB	typ. dB	max.	typ.				
0,35	0,3	1,25	1,15	-10 to 60	Nfem	C1	2100
0,35	0,3	1,25	1,15	-10 to 40 (2)	HF7/16	C3	2150
0,35	0,3	1,25	1,15	-10 to 60	Nfem	C1	2100
0,35	0,3	1,25	1,15	-10 to 40 (2)	HF7/16	C3	2150
0,5	0,35	1,25	1,15	-10 to 60	Nfem	C17	400
0,5	0,35	1,25	1,15	-10 to 60	Nfem	C14	400
0,35	0,20	1,25	1,15	-10 to 60	Nfem	C4	1200
0,35	0,20	1,25	1,15	-10 to 60	HF7/16	C5	1200
0,35	0,25	1,20	1,15	-10 to 70	Nfem	C1	2080
0,35	0,25	1,25	1,15	-10 to 70	HF7/16	C2	2200
0,35	0,17	1,25	1,12	-10 to 40 (2)	HF7/16	C3	2200
0,4	0,30	1,25	1,15	5 to 65 (2)	EIA1 5/8"	C37	3900
0,5	0,35	1,25	1,15	-10 to 60	Nfem	C17	400
0,5	0,35	1,25	1,15	-10 to 60	SMAfem	C18	400
0,5	0,35	1,25	1,15	-10 to 60	SMAfem	C16	400
0,5	0,35	1,25	1,15	-10 to 60	Nfem	C14	400
0,5	0,35	1,25	1,15	-10 to 60	Nmale	C15	400
0,35	0,25	1,25	1,15	-10 to 60	Nfem	C4	1200
0,35	0,25	1,25	1,15	-10 to 60	HF7/16	C5	1200
0,35	0,25	1,20	1,15	-10 to 70	Nfem	C1	2080
0,35	0,25	1,25	1,15	-10 to 70	HF7/16	C2	2200
0,35	0,17	1,25	1,13	-10 to 40 (2)	HF7/16	C3	2200
0,35	0,20	1,25	1,15	-10 to 60	Nfem	C4	1200
0,35	0,20	1,25	1,15	-10 to 60	HF7/16	C5	1200
0,35	0,25	1,20	1,15	-10 to 70	Nfem	C1	2080
0,35	0,25	1,25	1,15	-10 to 70	HF7/16	C2	2200
0,35	0,25	1,25	1,15	-10 to 70	HF7/16	C3	2200
0,35	0,15	1,20	1,10	-10 to 40 (2)	HF7/16	C3	2200
0,4	0,30	1,25	1,15	5 to 65 (2)	EIA1 5/8"	C37	3900
0,35	0,20	1,25	1,15	-10 to 60	Nfem	C4	1200
0,35	0,25	1,25	1,15	-10 to 60	HF7/16	C5	1200
0,35	0,25	1,20	1,15	-10 to 70	Nfem	C1	2080
0,35	0,25	1,25	1,15	-10 to 70	HF7/16	C2	2200
0,35	0,25	1,25	1,15	-10 to 70	HF7/16	C3	2200
0,35	0,16	1,20	1,15	-10 to 40 (2)	HF7/16	C3	2200
0,4	0,30	1,25	1,15	5 to 65 (2)	EIA1 5/8"	C37	3900
0,5	0,30	1,25	1,14	-10 to 60	Nfem	C14	400

Notes for TV band IV/V

- Other connectors can be provided on request.
- If the devices are air cooled, dry-air should be used at a pressure of 250 Pa and with a maximum intake temperature of 40 °C. The connector temperature should then not exceed 55 °C.

MICROWAVE COMMUNICATION: COAXIAL

frequency range (1) GHz	circulator (c) isolator (i)	max. c.w. power		catalogue number	isolation	
		forw. W	refl. W		min. dB	typ. dB
1,427-1,535	c	10		1722 162 03802	20	23
	i	10	1			
1,470-1,620	i	1	1	02492	20	23
	i	15	2	02521	20	23
1,590-1,800	i	1	1	02631	20	23
	i	15	2	02531	20	23
1,760-1,940	i	1	1	02641	20	23
	i	15	2	02541	20	23
1,890-2,110	i	1	1	02651	20	23
	i	15	2	02551	20	23
1,700-2,100	i	15	2	02661	20	23
	i	15	2	02571	26	28
	i	15	2	02581	26	28
1,900-2,300	cc (2)	30		04051	26	28
	i	15	2	02591	26	28
	i	15	2	02601	26	28
	cc. (2)	30		04061	26	28
3,8-4,2	c	10		03431	25	27
	cc (2)	10		04031	25	27
4,4-5	c	10		03441	25	27
	cc (2)	10		04041	25	27
7,99-10,2	i	5	1	02231	20	22
8,9-9,6	i	5	1	02501	20	22

Notes

1. Other frequency ranges and other connectors are available on request.
2. "CC" denotes a 4-port circulator.

Isolators and circulators

insertion loss		v.s.w.r.		temperature range °C	connector type (1)	dimensions see Fig. no.	mass approx. g
max. dB	typ. dB	max.	typ.				
0,4	0,3	1,25	1,15	0 to 55	Nfem	C14	400
0,4	0,3	1,25	1,15	0 to 55	Nfem	C17	400
0,4	0,3	1,25	1,15	0 to 55	solder pin	C24	
0,4	0,3	1,25	1,15	0 to 55	SMAfem	C25	
0,4	0,3	1,25	1,15	0 to 55	solder pin	C24	
0,4	0,3	1,25	1,15	0 to 55	SMAfem	C25	
0,4	0,3	1,25	1,15	0 to 55	solder pin	C24	
0,4	0,3	1,25	1,15	0 to 55	SMAfem	C25	
0,4	0,3	1,25	1,15	0 to 55	solder pin	C24	
0,4	0,3	1,25	1,15	0 to 55	SMAfem	C25	
0,25	0,2	1,11	1,09	0 to 55	SMAfem + m	C26	
0,25	0,2	1,11	1,09	0 to 55	SMAm + fem	C26	
0,25	0,2	1,11	1,09	0 to 55	SMAfem + m	C27	800
0,25	0,2	1,11	1,09	0 to 55	SMAfem + m	C26	
0,25	0,2	1,11	1,09	0 to 55	SMAm + fem	C26	
0,25	0,2	1,11	1,09	0 to 55	SMAfem + m	C27	800
0,25	0,2	1,12	1,10	-10 to 70	SMAfem	C31	110
0,25	0,2	1,12	1,10	-10 to 70	SMAfem	C32	220
0,25	0,2	1,12	1,10	-10 to 70	SMAfem	C31	110
0,25	0,2	1,12	1,10	-10 to 70	SMAfem	C32	220
0,4	0,35	1,25	1,23	-10 to 70	SMAfem	C33	30
0,4	0,35	1,25	1,23	-10 to 70	SMAfem	C34	30

NAVIGATION: COAXIAL

frequency range GHz	circulator (c) isolator (i)	max. forward power		catalogue number	isolation	
		c.w. W	peak W		min. dB	typ. dB
0,96-1,225 4,2-4,4	c	100	1000	2722 162 03591 02471	20	22
	i	10			23	

GENERAL PURPOSE, OCTAVE BANDWIDTH: COAXIAL

frequency range GHz	circulator (c) isolator (i)	max. c.w. power		catalogue number	isolation	
		forw. W	refl. W		min. dB	typ. dB
2-4	c	50		2722 162 01491 01501 02091 02101	20	24
	c	50			20	24
	i	50	5		20	24
	i	50	5		20	24
3-6	c	20		01511 02071	20	27
	i	20	5		20	27
4-8	c	10		01811 02111	20	23
	i	10	1		20	27
7-12,4	c	10		01822 02122	20	23
	i	10	1		20	25
7,99-10,2 8,9-9,6	i	5	1	02231 02501	20	22
	i	5	1		20	22
12-18	c	5		03301 02221	18	22
	i	5	1		18	22

INDUSTRIAL HEATING: WAVEGUIDE

frequency range GHz	circulator (c) isolator (i)	max. c.w. power		catalogue number (1)	isolation	
		forw. kW	refl. kW		min. dB	typ. dB
2,35-2,4	i	6,5	6,5	2722 163 02024 02025	20	26
	i(L)	6,5	6,5		20	26
2,425-2,475	i	6,5	6,5	02004 02005	20	26
	i(L)	6,5	6,5		20	26

Notes for industrial heating

1. These types are water cooled; air cooled versions for max. 3 kW can be made available on request.
2. Water inlet temperature: 10 to 40 °C. Water outlet temperature max. 50 °C. Storage temperature: -10 to 70 °C.
3. In case of short-circuited output, v.s.w.r. max. 1,5.

Isolators and circulators

insertion loss		v.s.w.r.		temperature range °C	connector type	dimensions see Fig. no.	mass approx. g
max. dB	typ. dB	max.	typ.				
0,5	0,35	1,25	1,20	-10 to 60	Nfem	C14	460
0,3		1,2		-55 to 90	SMAfem	C30	110

insertion loss		v.s.w.r.		temperature range °C	connector type	dimensions see Fig. no.	mass approx. g
max. dB	typ. dB	max.	typ.				
0,5	0,35	1,25	1,15	-10 to 70	Nfem	C10	300
0,5	0,35	1,25	1,15	-10 to 70	SMAfem	C11	300
0,5	0,35	1,25	1,1	-10 to 70	Nfem	C12	300
0,5	0,35	1,25	1,1	-10 to 70	SMAfem	C13	300
0,5	0,3	1,25	1,1	-10 to 70	SMAfem	C20	120
0,5	0,3	1,25	1,1	-10 to 70	SMAfem	C21	120
0,5	0,3	1,25	1,15	-10 to 70	SMAfem	C22	100
0,5	0,3	1,25	1,15	-10 to 70	SMAfem	C23	100
0,6	0,4	1,25	1,15	-10 to 70	SMAfem	C28	60
0,6	0,35	1,25	1,12	-10 to 70	SMAfem	C29	60
0,4	0,35	1,25	1,23	-10 to 70	SMAfem	C33	30
0,4	0,35	1,25	1,23	-10 to 70	SMAfem	C34	30
0,6	0,35	1,3	1,2	-10 to 70	SMAfem	C35	20
0,6	0,35	1,25	1,2	-10 to 70	SMAfem	C36	20

insertion loss		v.s.w.r.		temperature range (2) °C	flange IEC	dimensions see Fig. no.	mass approx. g
max. dB	typ. dB	max. (3)	typ.				
0,4	0,3	1,2	1,1		PDR26	W13	4700
0,4	0,3	1,2	1,1		monitor	W14	4700
0,3	0,2	1,2	1,1		output	W13	4700
0,3	0,2	1,2	1,1		Nfem	W14	4700

MICROWAVE COMMUNICATION: WAVEGUIDE

frequency range GHz	circulator (c) isolator (i)	max. c.w. power		catalogue number	isolation		
		forw. W	refl. W		min. dB	typ. dB	
3,4-3,8	c	50		2722 161 02242	28	35	
	cc	50			02262	28	35
3,8-4,2	c	50		02232	28	35	
	cc	50			02252	28	35
4,6-5,0	i	10	1	01101	30	35	
5,925-6,425	c	200		02211	28	35	
	i	200	3		04001	28	35
	i	20	2		01191	30	35
6,425-7,125	c	200		02311	28	35	
	i	200	3		04051	28	35
	i	20	2		01251	30	35
6,825-7,425	i	20	2	01231	30	35	
7,125-7,750	c	200		02321	28	35	
	i	200	3		04061	28	35
	i	20	2		01291	30	35
8,2-11,2	c	50		02071	22	30	

X-BAND RADAR: WAVEGUIDE

frequency range GHz	circulator (c) isolator (i)	max. c.w. power		catalogue number	isolation		
		forw. W	refl. W		min. dB	typ. dB	
8,5-9,6	i	1		2722 161 01222 (1)	15		
	i	5			01361	30	
	i	10			01211	30	
	i	10			01261	55	
10,025-10,325	i	1		01531	20		

Notes for X-band radar

1. Type 2722 161 01222 has a special rugged construction; spread of phase shift $\pm 5^\circ$.

Isolators and circulators

insertion loss		v.s.w.r.		temperature	flange	dimensions	mass
max.	typ.	max.	typ.	range	IEC	see Fig. no.	approx.
dB	dB			°C			g
0,2	0,15	1,08	1,04	0 to 55	UER40	W1	750
0,4	0,15	1,08	1,04	0 to 55	UER40	W2	1500
0,2	0,15	1,08	1,04	0 to 55	UER40	W1	750
0,4	0,15	1,08	1,04	0 to 55	UER40	W2	1500
0,5	0,30	1,05	1,03	10 to 40	UER48	W7	
0,2	0,15	1,08	1,04	0 to 55	UER70	W5	
0,2	0,15	1,08	1,04	0 to 55	UER70	W6	
0,3	0,15	1,05	1,03	-10 to 70	UER70	W8	1450
0,2	0,15	1,08	1,04	0 to 55	UER70	W5	
0,2	0,15	1,08	1,04	0 to 55	UER70	W6	
0,3	0,15	1,05	1,03	-10 to 70	UER70	W8	1450
0,3	0,15	1,05	1,03	-10 to 70	UER70	W8	1450
0,2	0,15	1,08	1,04	0 to 55	UER70	W5	
0,2	0,15	1,08	1,04	0 to 55	UER70	W6	
0,3	0,20	1,05	1,03	-10 to 70	UER70	W8	1450
0,5	0,30	1,18	1,15	10 to 40	UBR100	W3	

insertion loss		v.s.w.r.		temperature	flange	dimensions	mass
max.	typ.	max.	typ.	range	IEC	see Fig. no.	approx.
dB	dB			°C			g
0,6		1,15		10 to 70	UBR100	W9	400
0,5		1,05		-10 to 70	UBR100	W10	
0,5		1,05		-10 to 70	UBR100	W12	420
1,2		1,20		-10 to 70	UBR100	W11	600
0,4		1,25		-40 to 85	UBR100	W4	

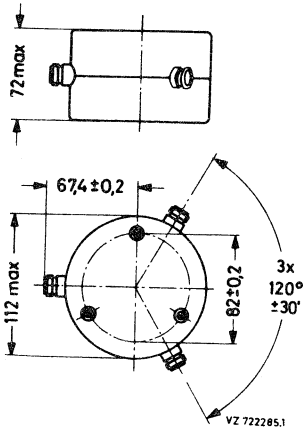

C1 2722 162 01121
 01131
 01141
 01851
 01861
 01871
 03171
 03191

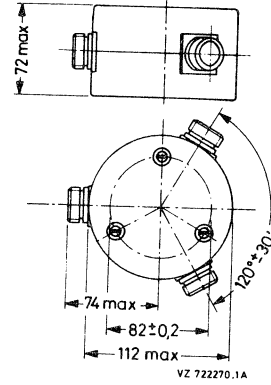

C2 2722 162 03141
 03151
 03201
 03211

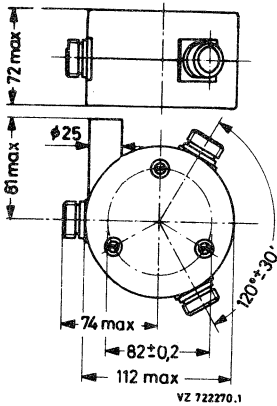

C3 2722 162 01261
 01271
 01281
 01331
 01881
 01891
 01901
 03181

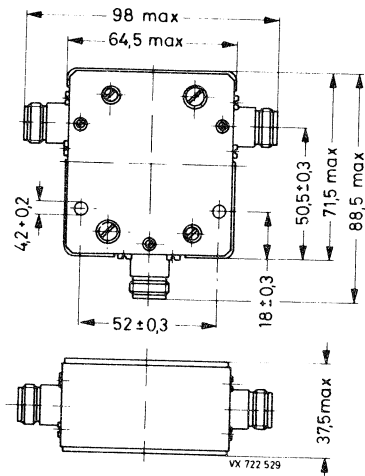

C4 2722 162 01572
 01582
 01592
 01601
 01612

Isolators and circulators

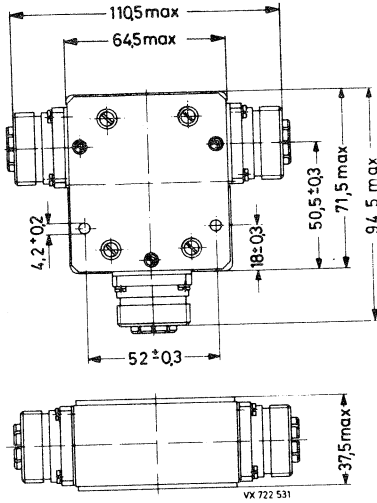

C5 2722 162 01632
01642
01651
01662

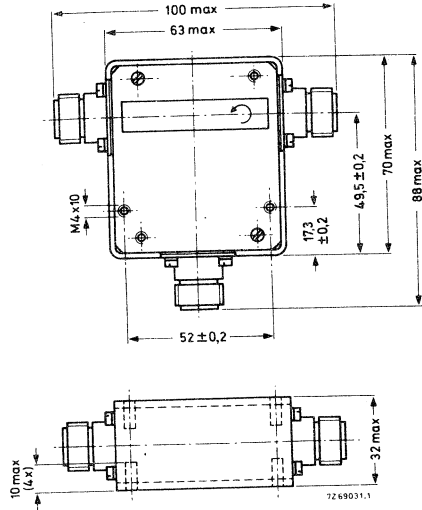

C6 2722 162 01931
01941
01951

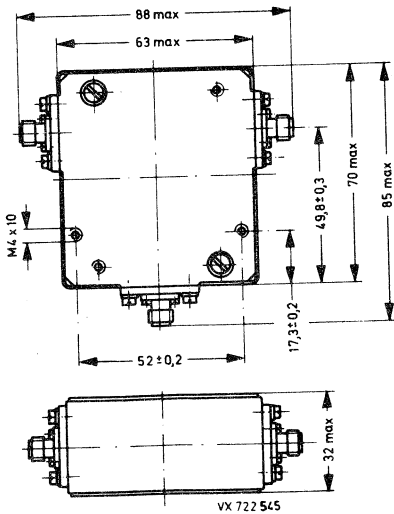

C7 2722 162 03421

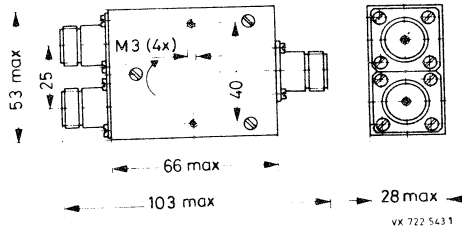

C8 2722 162 03732

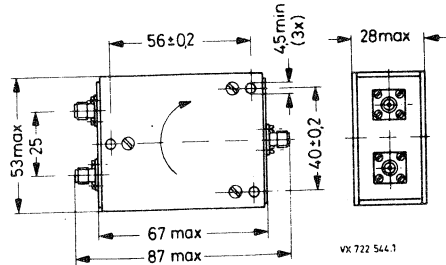

C9 2722 162 03722

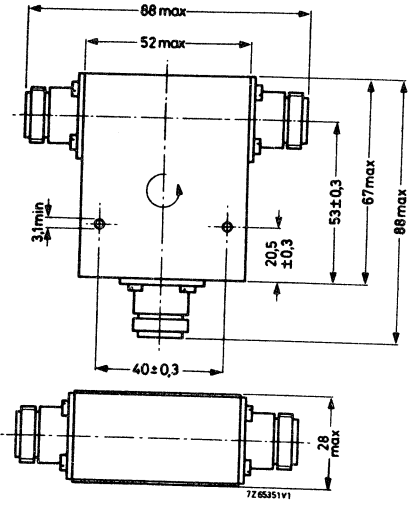

C10 2722 162 01491

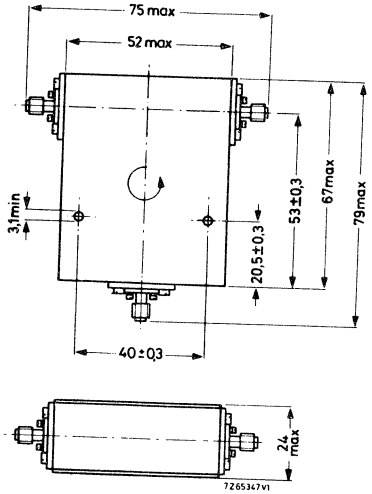

C11 2722 162 01501

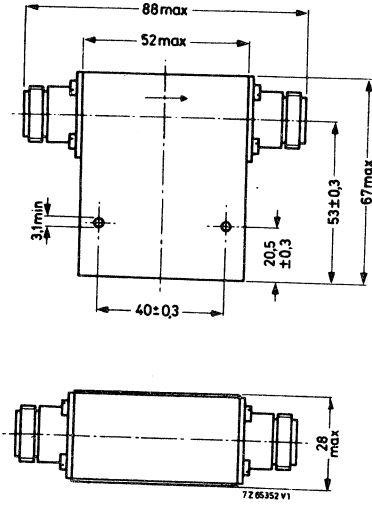

C12 2722 162 02091

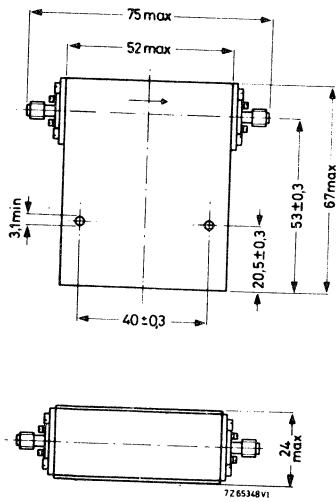

C13 2722 162 02101

Isolators and circulators

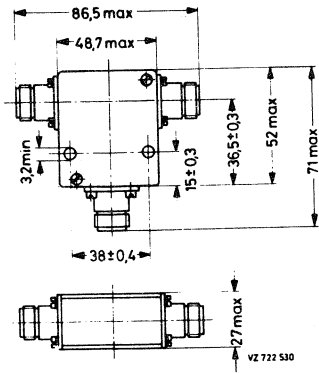

- C14 2722 162 01551
 01555
 01561
 03261
 03263
 03411
 03591
 03802
 03831
 03841
 03851
 05001

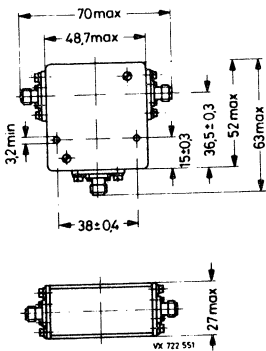

- C16 2722 162 05171
 03811
 03821

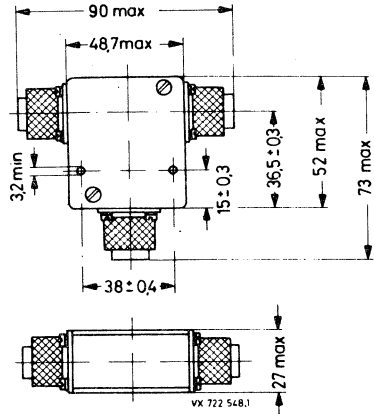

- C15 2722 162 03971

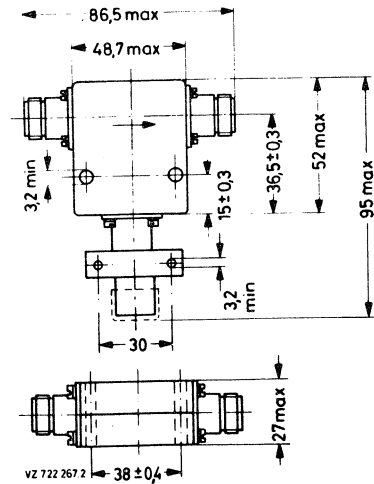

- C17 2722 162 02492
 02691
 02701
 02711
 02721
 02731
 02861
 02901
 02911
 02951
 02961

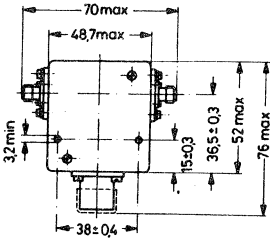

C18 2722 162 02741
02751
06011

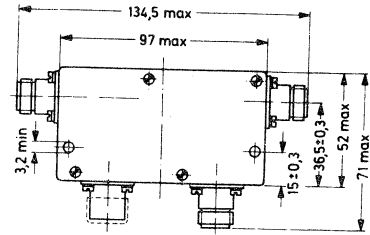

C19 2722 162 02851
02921
02931
02981

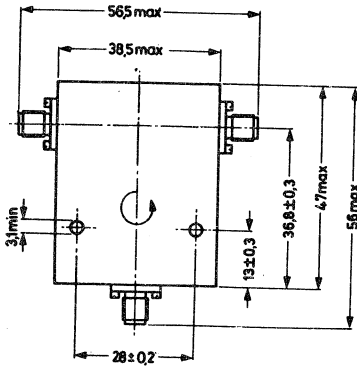

C20 2722 162 01511

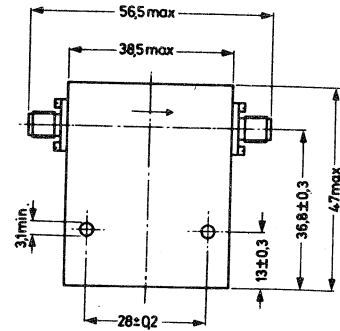

C21 2722 162 02071

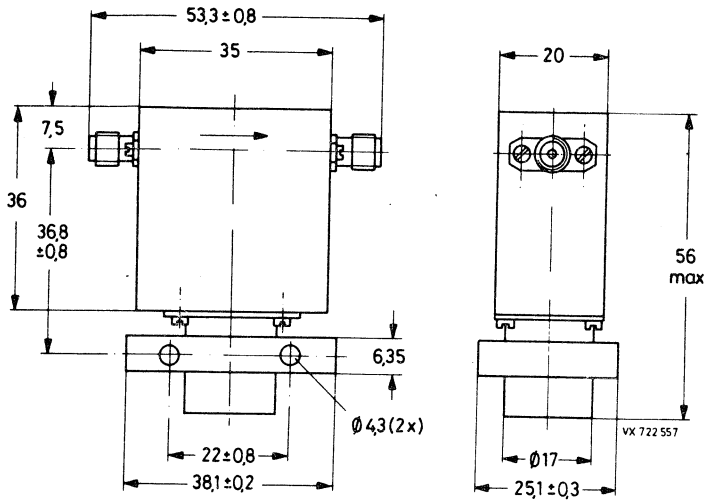

C25 2722 162 02631
 02641
 02651
 02661

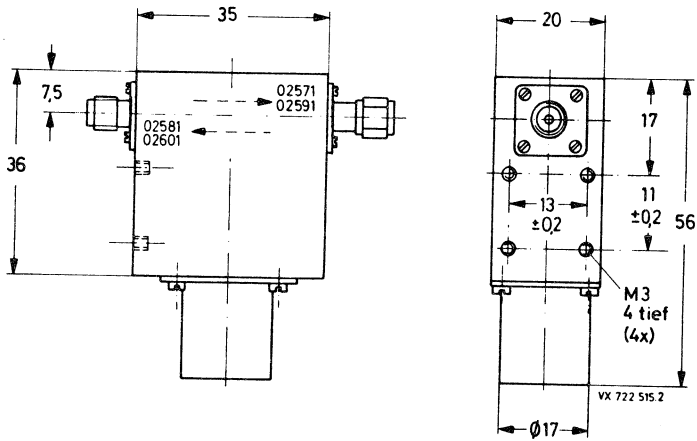

C26 2722 162 02571
 02581
 02591
 02601

Isolators and circulators

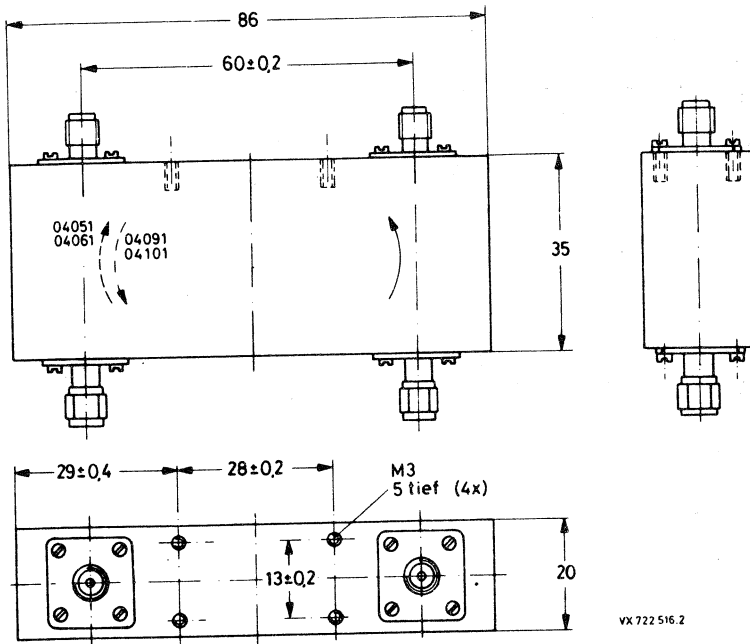

C27 2722 162 04051
04061

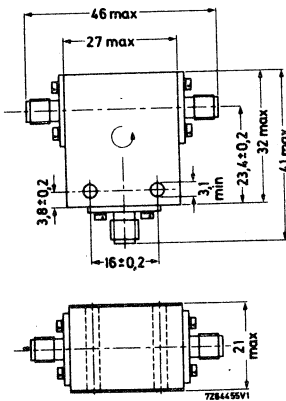

C28 2722 162 01822

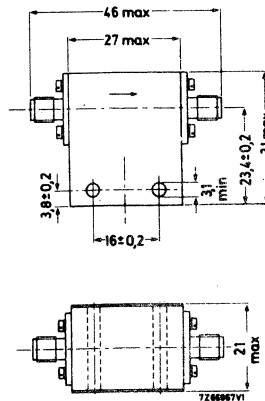

C29 2722 162 02122

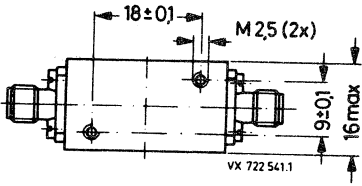
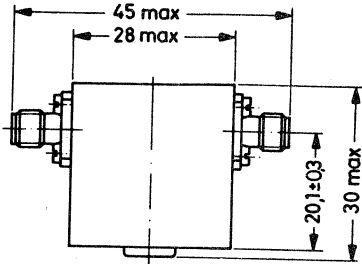

C30 2722 162 02471

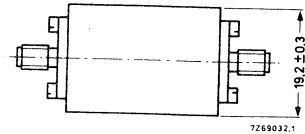
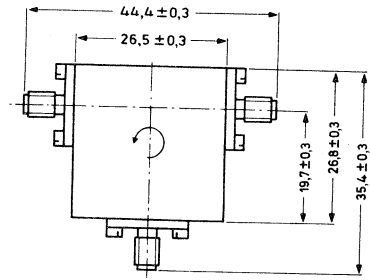

C31 2722 162 03431
03441

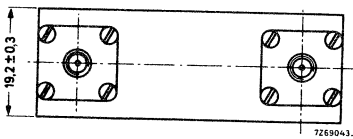
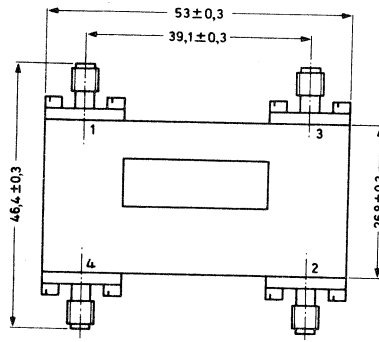

C32 2722 162 04031
04041

Isolators and circulators

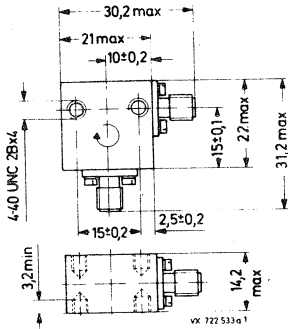

C33 2722 162 02231

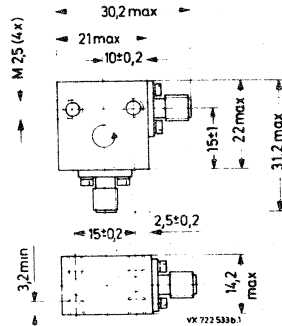

C34 2722 162 02501

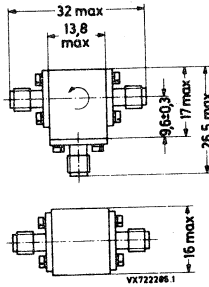

C35 2722 162 03301

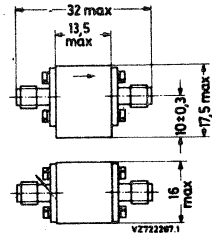

C36 2722 162 02221

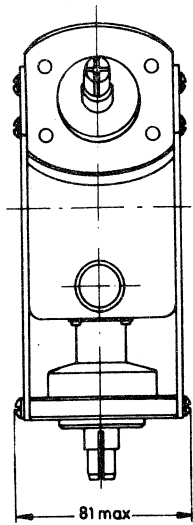
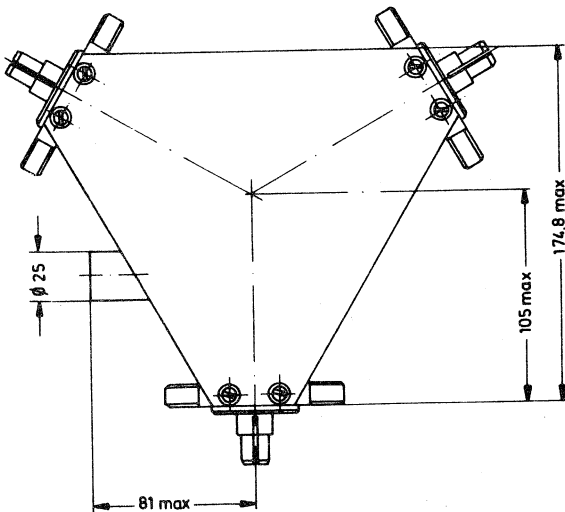

C37
2722 162 01981
03001
03011

VX 722 550

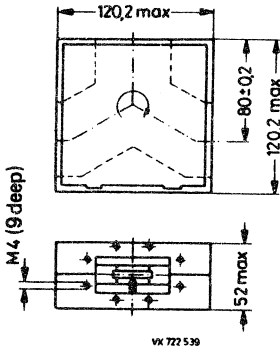

VX 722 539

W1 2722 161 02232
02242

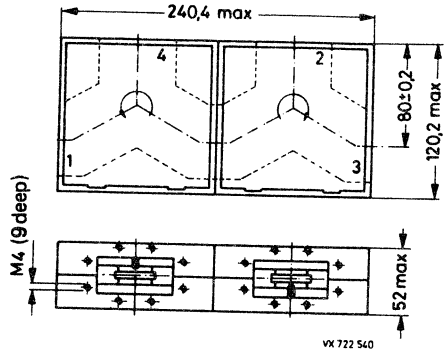

VX 722 540

W2 2722 161 02252
02262

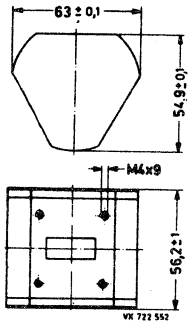

VX 722 552

W3 2722 161 02071

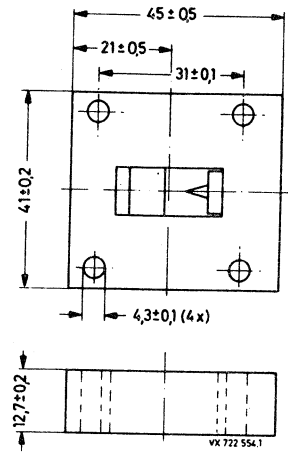

VX 722 554.1

W4 2722 162 01531

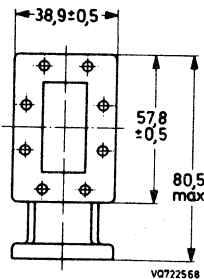
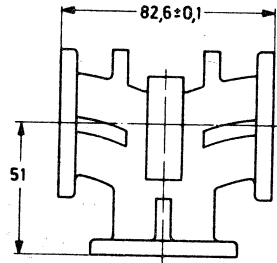

V0722568

W5 2722 161 02211
02311
02321

Isolators and circulators

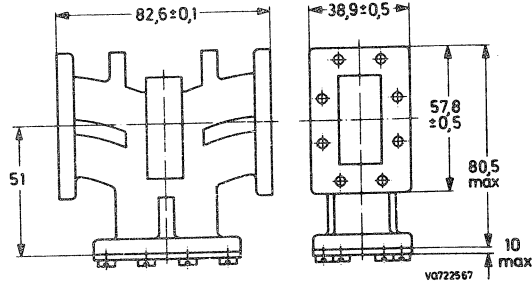

W6 2722 161 04001
04051
04061

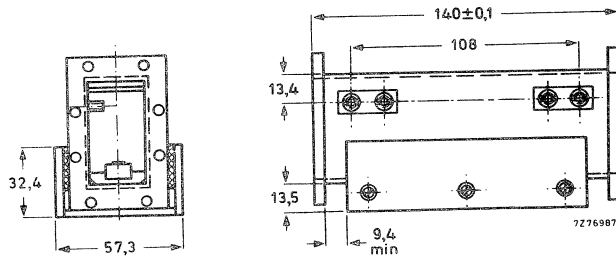

W7 2722 161 01101

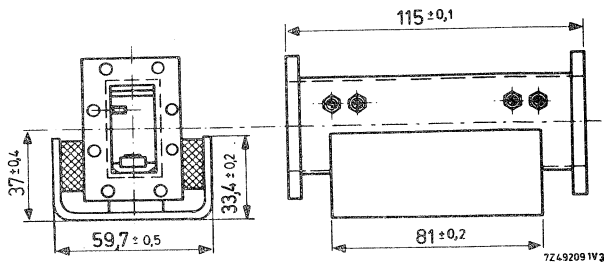

W8 2722 161 01191
01231
01251
01291

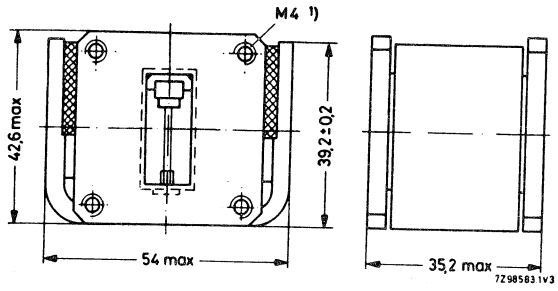

W9 2722 161 01222

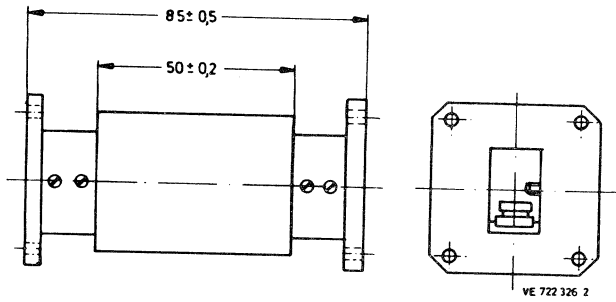

W10 2722 161 01361

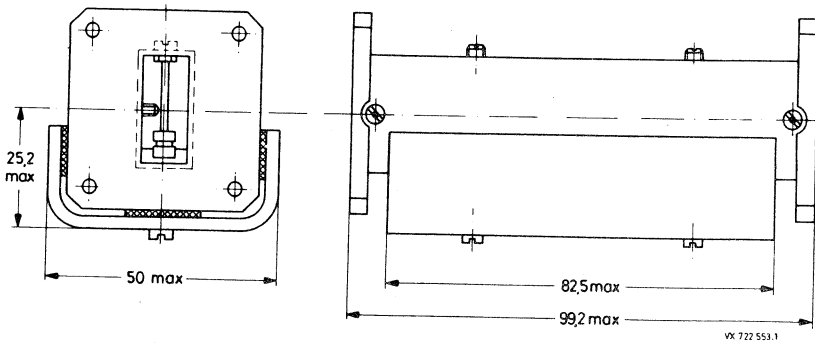

W11 2722 161 01261

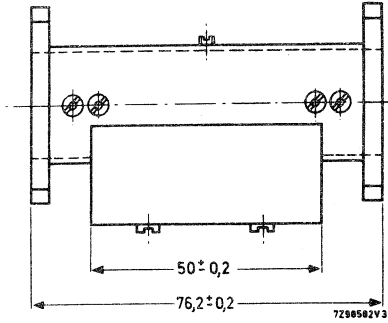
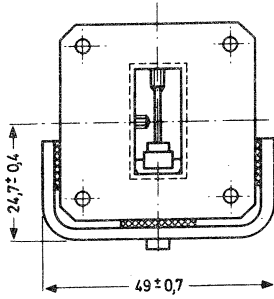

W12 2722 161 01211

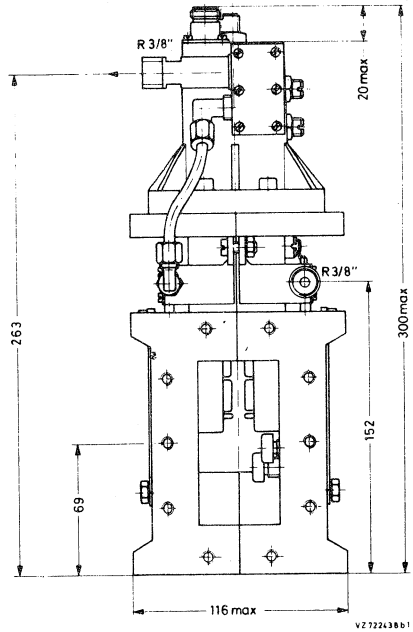
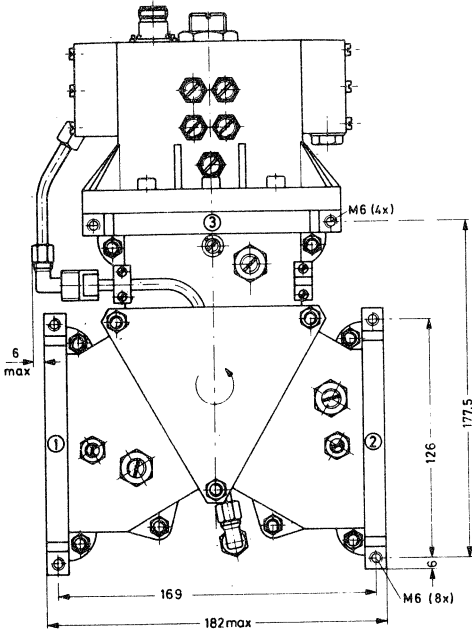

W13 2722 163 02004
02024

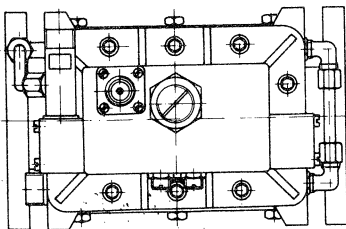

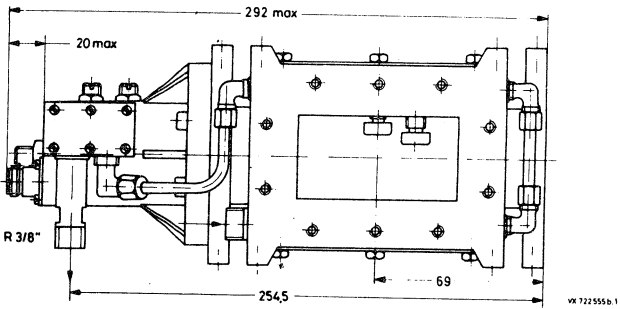
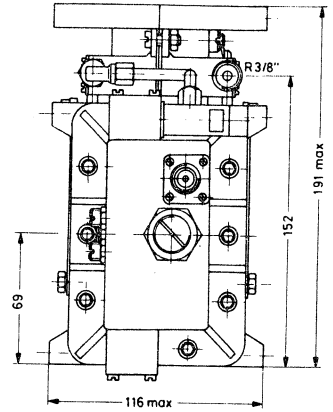
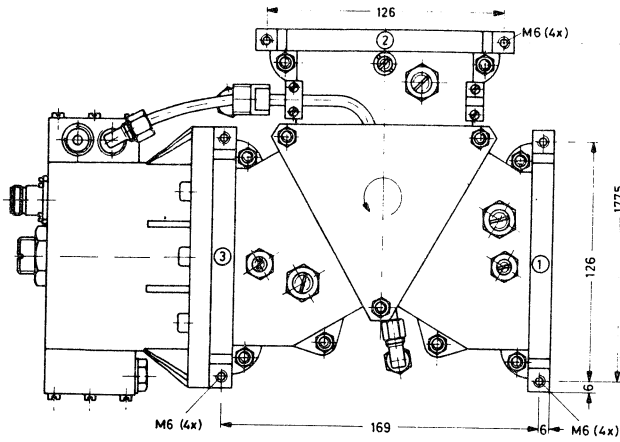

W14 2722 163 02005
02025



CONVERSION LISTS

Catalogue Number 2722 161	Type Number	Catalogue Number 2722 162	Type Number
01071	CL6201	01121	CL5027
01081	CL6240	01131	CL5028
01091	CL6202	01141	CL5029
01101	CL6203	01261	CL5261
01151	CL6210	01271	CL5271
01161	CL6214	01281	CL5282
01171	CL6215	01331	CL5331
01181	CL6217	01491	CL5491
01191	CL6206	01501	CL5501
01211	CL6222	01511	CL5511
01221	CL6221	01551	CL5551
01231	CL6231	01561	CL5561
01241	CL6241	01572	CL5372
01251	CL6251	01582	CL5382
01261	CL6261	01592	CL5392
01271	CL6271	01612	CL5312
01291	CL6291	01622	CL5322
02081	CL5281	01632	CL5332
02091	CL5291	01642	CL5342
02101	CL5101	01662	CL5362
02191	CL5219	01811	CL5811
02231	CL5232	01821	CL5821
02261	CL5263	01851	CL5851
02271	CL5227	01861	CL5861
02281	CL5283	01871	CL5871
03001	CL5050	01881	CL5881
03011	CL5051	01891	CL5891
03031	CL5053	01901	CL5901
03041	CL5054	01931	CL5931
03051	CL5055	01941	CL5941
03061	CL5056	01951	CL5951
03081	CL5081	02041	CL6041
03091	CL5091	02071	CL6071

CONVERSION LISTS

Catalogue Number 2722 162	Type Number
02091	CL6091
02101	CL6101
02111	CL6111
02121	CL6122
02221	CL6223
02231	CL6232
03171	CL5172
03181	CL5182
03261	CL5262
03301	CL5301
03411	CL5411
03431	CL5431
03441	CL5441
03591	CL5592
04031	CL5032
04041	CL5042

Catalogue Number 2722 163	Type Number
02004	CL6204
02024	CL6224



CONVERSION LISTS

Type Number	Catalogue Number
CL5027	2722 162 01121
CL5028	2722 162 01131
CL5029	2722 162 01141
CL5032	2722 162 04031
CL5042	2722 162 04041
CL5050	2722 161 03001
CL5051	2722 161 03011
CL5053	2722 161 03031
CL5054	2722 161 03041
CL5055	2722 161 03051
CL5056	2722 161 03061
CL5081	2722 161 03081
CL5091	2722 161 03091
CL5101	2722 161 02101
CL5172	2722 162 03171
CL5182	2722 162 03181
CL5219	2722 161 02191
CL5227	2722 161 02271
CL5232	2722 161 02231
CL5261	2722 162 01261
CL5262	2722 162 03261
CL5263	2722 161 02261
CL5271	2722 162 01271
CL5281	2722 161 02081
CL5282	2722 162 01281
CL5283	2722 161 02281
CL5291	2722 161 02091
CL5301	2722 162 03301
CL5312	2722 162 01612
CL5322	2722 162 01622
CL5331	2722 162 01331
CL5332	2722 162 01632
CL5342	2722 162 01642

Type Number	Catalogue Number
CL5362	2722 162 01662
CL5372	2722 162 01572
CL5382	2722 162 01582
CL5392	2722 162 01592
CL5411	2722 162 03411
CL5431	2722 162 03431
CL5441	2722 162 03441
CL5491	2722 162 01491
CL5501	2722 162 01501
CL5511	2722 162 01511
CL5551	2722 162 01551
CL5561	2722 162 01561
CL5592	2722 162 03591
CL5811	2722 162 01811
CL5821	2722 162 01821
CL5851	2722 162 01851
CL5861	2722 162 01861
CL5871	2722 162 01871
CL5881	2722 162 01881
CL5891	2722 162 01891
CL5901	2722 162 01901
CL5931	2722 162 01931
CL5941	2722 162 01941
CL5951	2722 162 01951
CL6041	2722 162 02041
CL6071	2722 162 02071
CL6091	2722 162 02091
CL6101	2722 162 02101
CL6111	2722 162 02111
CL6122	2722 162 02121
CL6201	2722 161 01071
CL6202	2722 161 01091
CL6203	2722 161 01101

CONVERSION LISTS

Type Number	Catalogue Number
CL6204	2722 163 02004
CL6206	2722 161 01191
CL6210	2722 161 01151
CL6214	2722 161 01161
CL6215	2722 161 01171
CL6217	2722 161 01181
CL6221	2722 161 01221
CL6222	2722 161 01211
CL6223	2722 162 02221
CL6224	2722 163 02024
CL6231	2722 161 01231
CL6232	2722 162 02231
CL6240	2722 161 01081
CL6241	2722 161 01241
CL6251	2722 161 01251
CL6261	2722 161 01261
CL6271	2722 161 01271
CL6291	2722 161 01291



MISCELLANEOUS

XXXXXXXXXX
XXXXXXXXXX
XXXXXXXXXX
XXXXXXXXXX
XXXXXXXXXX
XXXXXXXXXX

P

MICROWAVE HORN ANTENNA

A general purpose X-band antenna for miniature radar systems.
The unit gives a low v.s.w.r. and is of a strong cast construction.

QUICK REFERENCE DATA

CHARACTERISTICS

Frequency range	9.0 to 11	GHz
Gain	16	dB
Beam angle (both planes)	30	deg
v.s.w.r. max.	1.2	

MECHANICAL DATA

Weight	160	g
Flange	UBR100 (UG135/U)	

This data must be read in conjunction with GENERAL SAFETY RECOMMENDATIONS –
MICROWAVE SEMICONDUCTORS

MECHANICAL DATA

Dimensions in mm

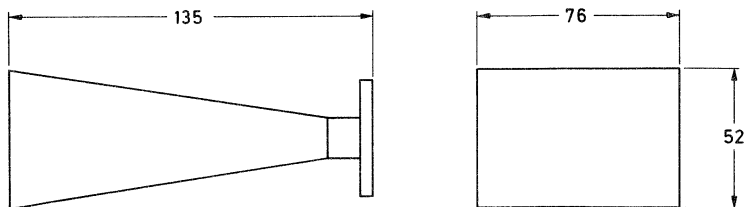

All dimensions in mm

06006

PARAMETRIC AMPLIFIER

A single-diode non-degenerate parametric amplifier designed for use as a low-noise pre-amplifier in microwave applications. It is supplied in a temperature stabilized enclosure with a solid state Gunn-effect oscillator pump and integral power supply.

QUICK REFERENCE DATA

Power gain	20	dB
Tuning range min.	2.7 to 3.1	GHz
Noise figure max.	2.8	dB
Bandwidth	15	MHz
Input and output impedance	50	Ω
Mains supply	240 V, 2 A, 50 Hz	

This data must be read in conjunction with GENERAL SAFETY RECOMMENDATIONS – MICROWAVE SEMICONDUCTORS

MECHANICAL DATA

Dimensions in mm

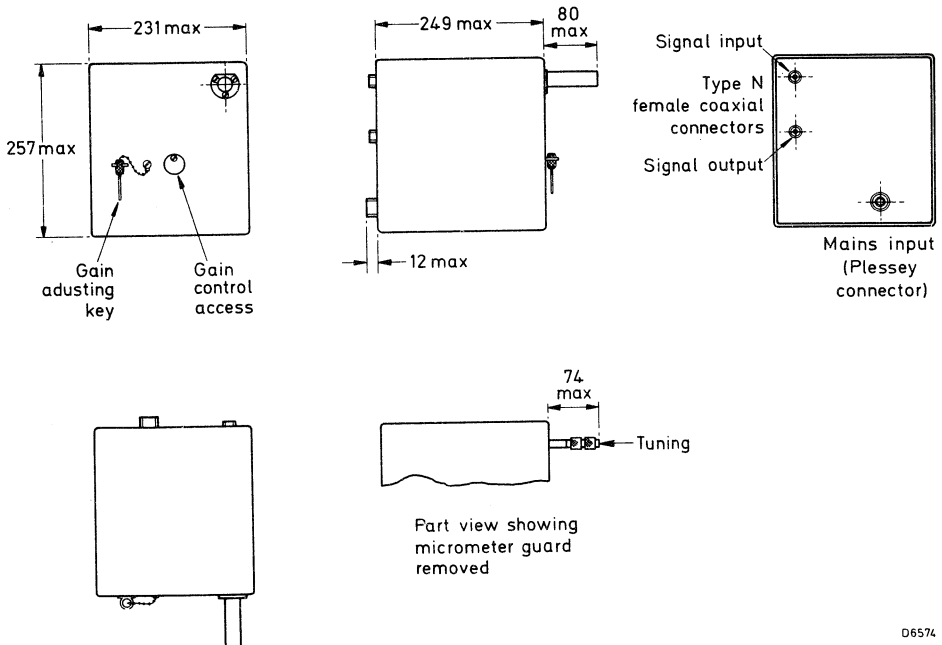

06574

RATINGS

Limiting values in accordance with the Absolute Maximum System (IEC134)

Continuous r.f. input power	max.	100	mW
Input spike energy	max.	500	nJ
Mains supply voltage	max.	276	V _{ac}
Ambient operating temperature range		-20 to +55	°C
Storage temperature range		-30 to +70	°C

CHARACTERISTICS (note 1)

T_{amb} = 25 °C

	min.	typ.	max.	
Power gain (recommended setting) (note 2)	—	20	—	dB
Operating frequency	2.7	—	3.1	GHz
Noise figure	—	2.6	2.8	dB
Bandwidth (note 3)	12	—	18	MHz
Input saturation level (note 4)	-35	-32	—	dBm
Gain stability per hour		±0.1		dB
per day		±0.5		dB
Mains voltage supply limits	204	240	276	V _{ac}
MASS		5.4		kg

Notes

1. These are given for matched conditions.
2. The gain-set attenuator is adjusted with the hexagonal key provided.
3. Measured to the 3 dB points at a gain setting of 20 dB.
4. This is the input level at which the gain is compressed by 1 dB, at a gain setting of 20 dB.
5. The amplifier is designed for ease of maintenance; both the temperature control system and the Gunn oscillator power supply use field-replaceable plug-in boards.



DEVELOPMENT SAMPLE DATA

This information is derived from development samples made available for evaluation. It does not necessarily imply that the device will go into regular production.

JA1010

X-BAND SOLID STATE LINEAR POWER FET AMPLIFIER

A solid state linear class-A amplifier for use as a driver amplifier for TWT power stages in radar equipment

QUICK REFERENCE DATA

Frequency	8,5 to 9,6 GHz
Gain	32 ± 2 dB
Output power (1 dB compression)	> 30 dBm

This data must be read in conjunction with GENERAL SAFETY RECOMMENDATIONS – MICROWAVE SEMICONDUCTORS

MECHANICAL DATA

Dimensions in mm

Outline drawing

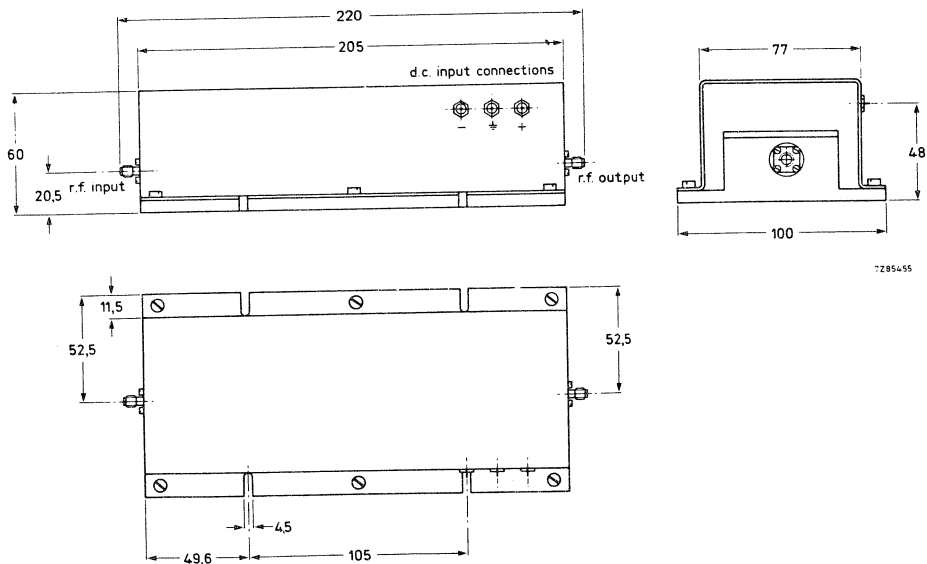

Input connector
Output connector
D.C. input

SMA female
SMA female
solder pins

OPERATING CONDITIONS

D.C. power supply	1,5 A	+12 V ± 5%
	200 mA	-12 V ± 5%
Maximum r.f. input (damage level)		+20 dBm

ELECTRICAL CHARACTERISTICS

Frequency range		8,5 to 9,6 GHz
Small signal gain		32 ± 2 dB
Gain variation over frequency range		< 1 dB
Gain variation over operating temp. range and ± 5% variation of supply voltage		< ± 1 dB
Maximum input r.f. power (damage level)		+ 20 dBm
Output power at 1 dB compression point		> + 30 dBm
Input and output impedance		50 Ω
Input VSWR		< 1,5
Output VSWR		< 1,5
Spurious (other than IM) products, in a 1 MHz slot		< -60 dBm

ENVIRONMENTAL CHARACTERISTICS

Operating temperature		-10 to + 70 °C
Maximum base plate temperature		+ 70 °C
Storage temperature		-55 to + 85 °C
Relative humidity at + 40 °C		95%

Moisture resistance

according to MIL-STD-202E, method 106D, omit step 7

Shock

according to MIL-STD-202E, method 213E, cond. J

Vibration

according to MIL-STD-202E, method 201A

YIG-TUNED OSCILLATORS

These oscillators consist of a Gunn diode, a microstrip impedance transformer, a YIG sphere and electromagnetic coils. They are intended for use in wideband equipment for civil and military applications in frequency bands from 8 to 18 GHz.

QUICK REFERENCE DATA

type	frequency range GHz	guaranteed minimum output power over tuning range mW
YG1103	8 - 12,4	40
YG1104	10 - 15	20
YG1105	12 - 18	20

This data must be read in conjunction with GENERAL SAFETY RECOMMENDATIONS – MICROWAVE SEMICONDUCTORS.

POTENTIAL HAZARD-BERYLLIUM OXIDE

This device contains beryllium oxide, the dust of which is toxic. The device is entirely safe, provided that the beryllium oxide disc is not damaged. Care should be taken to ensure that all those who may handle, use or dispose of this device are aware of its nature and of the necessary safety precautions. In particular, it should never be thrown out with general industrial or domestic waste.

MECHANICAL DATA

Dimensions in mm

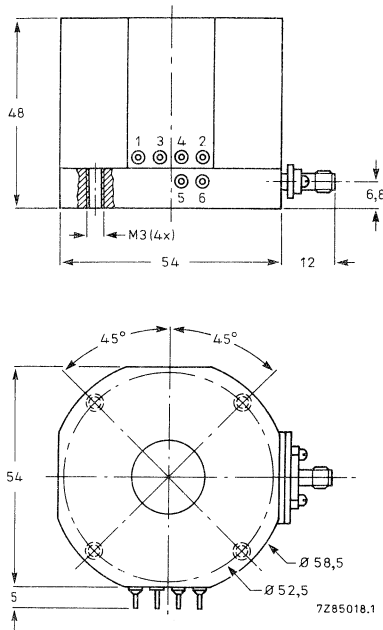

Connections:

- 1-2 Main coil
- 3-4 Fast coil
- 5 -V Gunn earth
- 6 +V Gunn

Fig. 1.

ELECTRICAL DATA

	YG1103	YG1104	YG1105
Frequency range	8 to 12,4	10 to 15	12 to 18 GHz
Linearity	typ. ± 2	± 3	± 3 %
→ Output power over tuning range, see Figs 5, 6 and 7, at 25 °C	min. 40	20	20 mW
Power variation in band, at 25 °C	max. 5	5	5 dB
Pulling (VSWR 1,5 : 1)	max. 15	15	15 MHz
Pushing	max. 20	20	20 MHz/V
Phase noise at 3 dBc	max. 50	50	50 kHz
Other parasitics	typ. -40	-40	-40 dBc
Second harmonic	typ. -20	-20	-20 dBc
Frequency drift from 0 to +50 °C	typ. 50	50	50 · 10 ⁻⁶ /°C
Sensitivity to external magnetic field	typ. 15	15	15 GHz/T
Hysteresis	typ. 10	12	15 MHz

OPERATING CONDITIONS

Supply voltage of Gunn diode

max.	15	14	12 V
------	----	----	------

Supply current of Gunn diode

max.	1.0	0.8	1.2 A
------	-----	-----	-------

Storage temperature

-55 to +125 °C

Operating temperature, measured on base plate of oscillator

0 to +50 °C

To obtain optimum characteristics over the whole band, the supply voltage to the Gunn diode must be adjusted with the frequency at the value indicated on the test sheet supplied with the product.

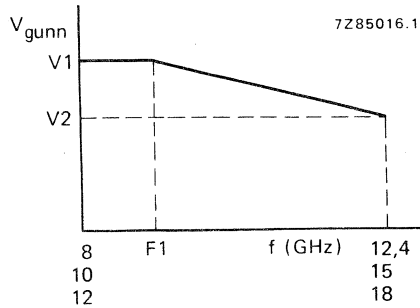

Fig. 2.

A curve giving measured data is supplied with each oscillator. The Gunn diode will be damaged if its polarity is reversed. Maximum supply voltages of the Gunn diode must not be exceeded. The oscillator must be bolted to a heatsink. To ensure good thermal contact, the oscillator has an unpainted machined flat baseplate.

Typical coil data

see Fig. 3.

Main coil:

Tuning sensitivity up to 100 Hz	17,5 MHz/mA
Current	< 1,2 A
Resistance	7 Ω
Inductance at 1 kHz	165 \pm 15 mH

Fast coil:

Tuning sensitivity at 100 Hz, Fig. 4	typ. 320 kHz/mA
Tuning sensitivity at 1 MHz, Fig. 4	typ. 90 kHz/mA
Resistance	< 1 Ω
Inductance	< 10 μ H
Current	< 1 A

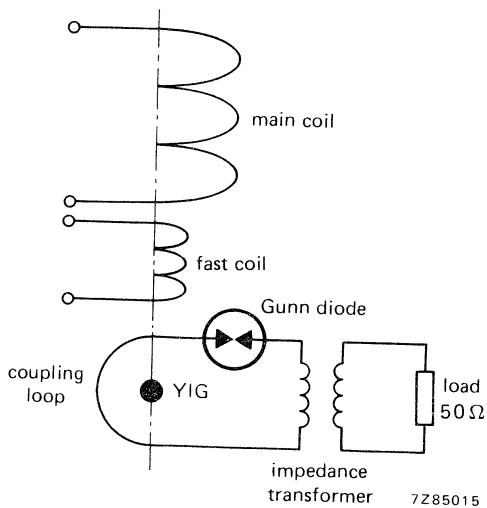

Fig. 3.

PERFORMANCE CURVES

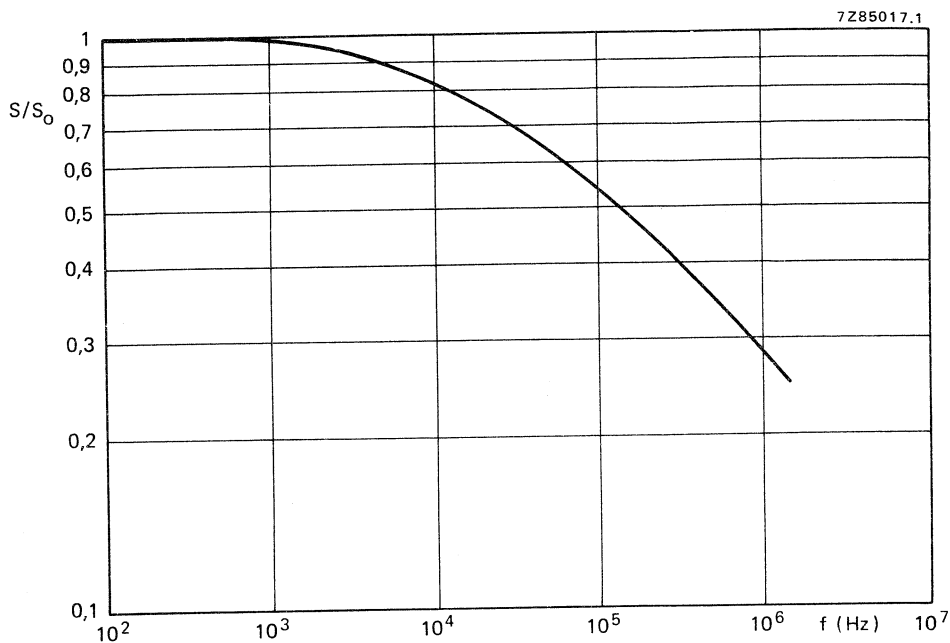

Fig. 4 Typical sensitivity variation of the fast coil versus the sweeping frequency
 $S_0 = 320 \text{ kHz/mA}$.

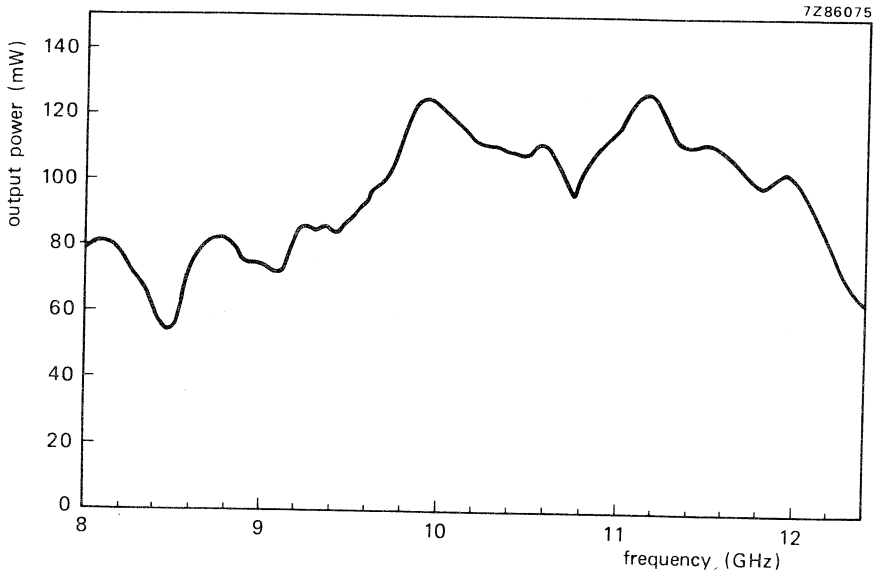

Fig. 5 Typical test curve of YG1103.

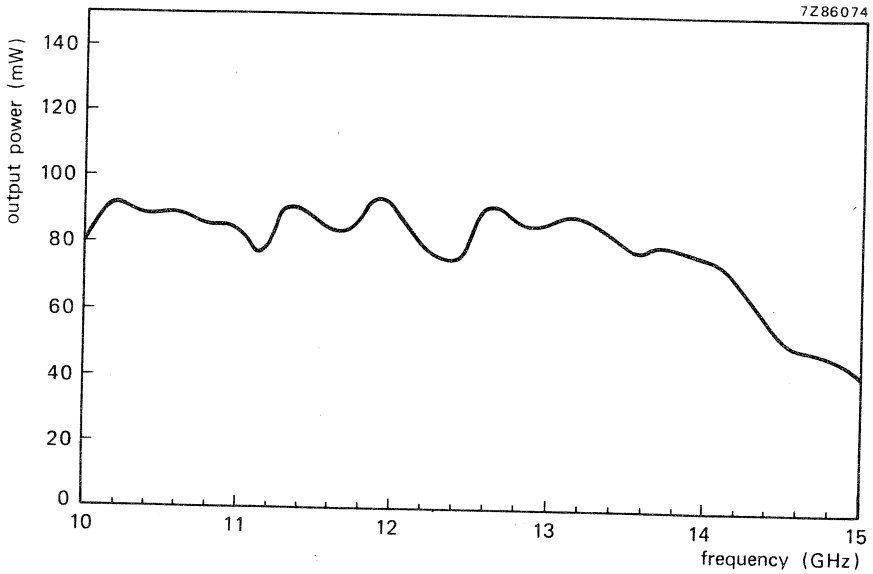

Fig. 6 Typical test curve of YG1104.

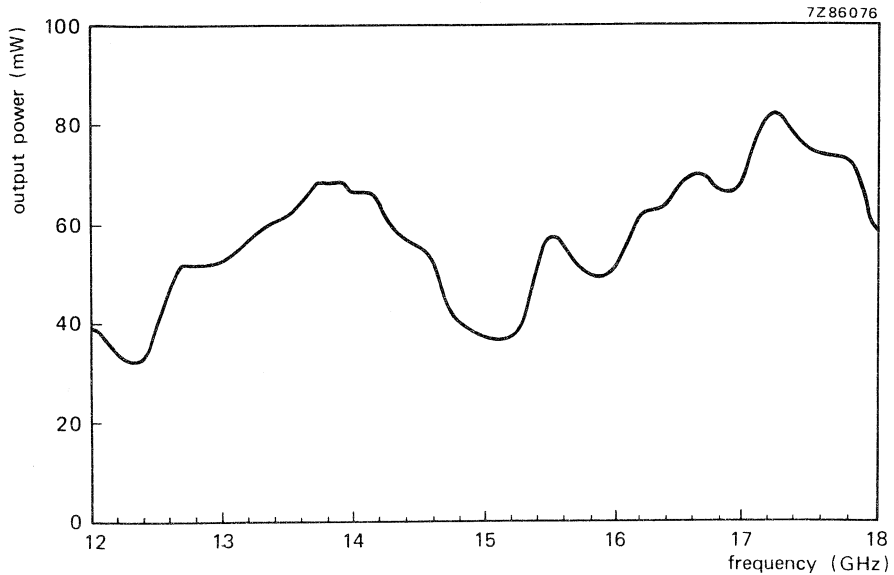

Fig. 7 Typical test curve of YG1105.

YIG TUNED-OSCILLATOR

This hermetically sealed, very linear and temperature stabilized YIG tuned-oscillator consists of a Gunn diode, a microstrip impedance transformer, a YIG sphere and electromagnetic coils. It is intended for use in wideband equipment for military applications in the frequency band from 12 to 18 GHz and features an operating temperature range from -40 to $+85$ °C.

QUICK REFERENCE DATA

Frequency range		12 to 18	GHz
Frequency drift with temperature -40 to 85 °C	max.	± 25	MHz
Overall linearity, over total operating temperature range		$<\pm 50$	MHz
Output power, over total tuning range and over total temperature range	typ.	20	mW

This data must be read in conjunction with GENERAL SAFETY RECOMMENDATIONS – MICROWAVE SEMICONDUCTORS.

POTENTIAL HAZARD-BERYLLIUM OXIDE

This device contains beryllium oxide, the dust of which is toxic. The device is entirely safe provided that the beryllium oxide disc is not damaged. Care should be taken to ensure that all those who may handle, use or dispose of this device are aware of its nature and of the necessary safety precautions. In particular, it should never be thrown out with general industrial or domestic waste.

MECHANICAL DATA

Dimensions in mm

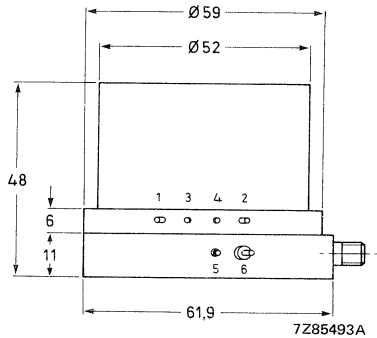
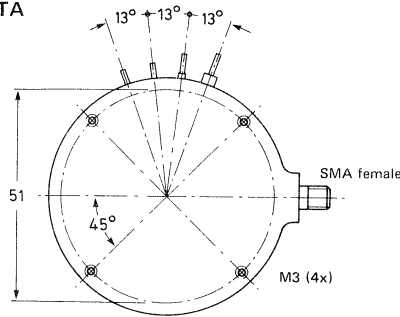

- Connections:
- 1-2 Main coil
 - 3-4 Fast coil
 - 5 -V Gunn earth
 - 6 +V Gunn

WARNING

This oscillator contains beryllium oxide the dust of which is toxic. Do not open the oscillator.

ELECTRICAL DATA

Frequency range	12 to 18 GHz
Linearity	see Figs 4 and 6
Output power over tuning range (Fig. 5)	min. 15 mW
Power variation in band	max. 8 dB
Pulling (VSWR 1,4 : 1)	max. ± 5 MHz
Pushing	max. 12 MHz/V
Phase noise at 3 dBc	max. 50 kHz
Other parasitics	max. -50 dBc
Second harmonic	max. -15 dBc
Frequency drift as a function of temperature	see Fig. 4
Sensitivity to external magnetic field at 50 Hz	max. 10 GHz/T
Hysteresis	typ. 15 MHz

OPERATING CONDITIONS

Supply voltage of Gunn diode

typ. 4 to 10 V

Supply current of Gunn diode

typ. 1 A

Storage temperature

-55 to 110 °C

Operating temperature, measured on
base plate of oscillator

-40 to 85 °C

To obtain optimum characteristics over the whole band, the supply voltage to the Gunn diode must be adjusted with the frequency at the value indicated on the test sheet supplied with the product.

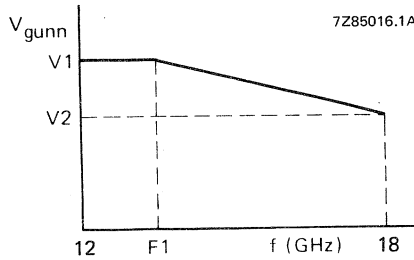

Fig. 2.

A curve giving measured data is supplied with each oscillator. The Gunn diode will be damaged if its polarity is reversed. Maximum supply voltages of the Gunn diode must not be exceeded. The oscillator must be bolted to a heatsink. To ensure good thermal contact, the oscillator has an unpainted machined flat baseplate.

Typical coil data

Main coil:

Tuning sensitivity up to 100 Hz
 Current (d.c.)
 Resistance
 Inductance at 1 kHz

see Fig. 3
 17,5 MHz/mA
 < 1,2 A
 ≲ 10 Ω
 170 mH

Fast coil:

Tuning sensitivity at 3 MHz, at $I_{p-p} \leq 2,2$ A
 Resistance
 Inductance
 Current (d.c.)

200 MHz
 typ. 1 Ω
 < 2,5 μH
 < 0,7 A

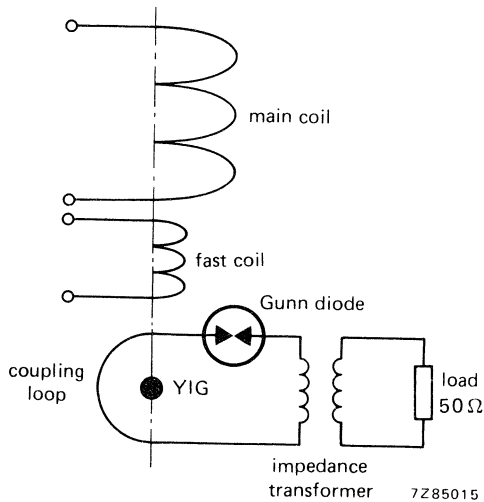

Fig. 3.

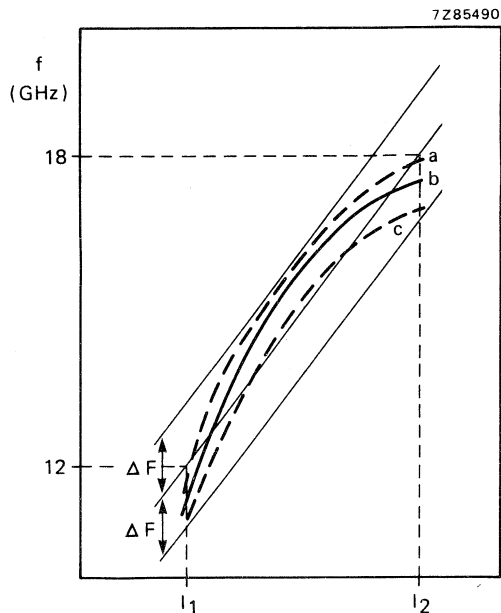

Fig. 4 Linear relation of frequency as a function of current in main coil; typical values, curve a at $-40\text{ }^{\circ}\text{C}$; curve b at $+25\text{ }^{\circ}\text{C}$ and curve c at $+85\text{ }^{\circ}\text{C}$. Deviation ΔF max. $\pm 50\text{ MHz}$ over the whole frequency range and operating temperature range. Frequency drift with temperature (-40 to $85\text{ }^{\circ}\text{C}$) at fixed current: max. $\pm 25\text{ MHz}$.

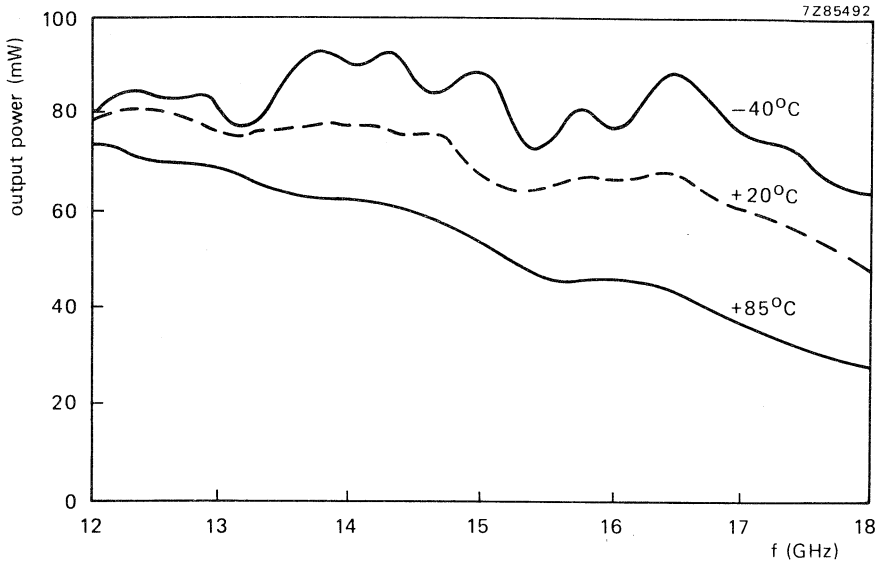
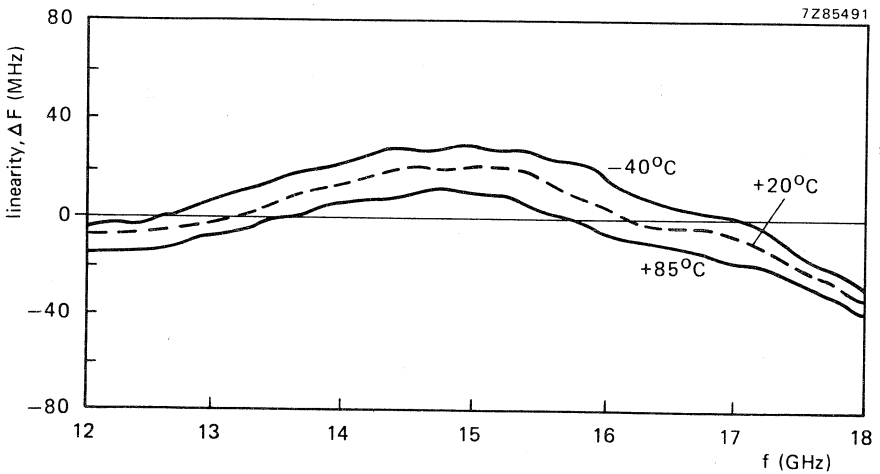

Fig. 5 Typical test curves, output power over tuning range.



INDEX

INDEX

Type number	Section	Type number	Section
ACX-01A	P	CL7500, 20	L
AEY17	D	CL8310	K
AEY29, R	D	CL8630 series	K
AEY31, A	D	CL8640R, T	K
AEY32	D	CL8690	K
AEY33	D	CL8880, 2 series	M
BAS22 to 25	C	CL8960 series	M
BAS46	C	CL9022	P
BAT10	C	CXY10	E
BAT11	C	CXY11A to C	B
BAT31	B	CXY12	E
BAT38	C	CXY14A to C	B
BAT39	C	CXY19	B
BAT50, R	C	CXY19A	B
BAT51, R	C	CXY19B	B
BAT52, R	C	CXY21	B
BAV22, R	C	CXY22A, B	G
BAV72	C	CXY23 series	F
BAV75	C	CXY24A, B	B
BAV96A to D	C	JA1010	P
BAV97	C	JM1000 series	L
BAW95D to G	C	JS1001, 2	K
BAY96	E	JS1101, 2	K
BFQ33	H	JS1200 series	K
BFR49	H	LAE4001R	H
BXY27	E	LAE4002S	H
BXY28	E	LAE6000Q	H
BXY29	E	LBE1004R, 1010R	H
BXY32	E	LCE1004R, 1010R	H
BXY35 to 41	E	LBE2003S, 2009S	H
BXY48	F	LCE2003S, 2009S	H
BXY50	B	LKE1004R	H
BXY51	B	LKE2015T	H
BXY52	B	LKE21004R	H
BXY53 series	F	LKE21050T	H
BXY56, 7	E	LKE32001QC	H
BXY60	B	LKE32002T, 4T	H
CAY10	E	LTE42005S	H
CFX13	J	LTE42008R	H
CFX21	J	PDE1001U, 1003U, 1005U, 1010U	H

Type number	Section
PEE1001U, 1003U, 1005U, 1010U	H
PKB20010U	H
PKB32001U, 32003U, 32005U	H
PTB42001X, 42002X	H
YG1100 series	P
YG1301E	P
1N415E	E
1N5152, 3	E
1N5155	E
1N5157	E

CONTENTS

A GENERAL SECTION

B GUNN, IMPATT AND NOISE DIODES

C MIXER AND DETECTOR DIODES

D BACKWARD DIODES

E MULTIPLIER VARACTOR DIODES

F TUNING VARACTOR DIODES

G LIMITER VARACTOR DIODES

H SILICON BIPOLAR TRANSISTORS

J GALLIUM ARSENIDE FET TRANSISTORS

K OSCILLATORS

L MIXER AND DETECTOR MODULES

M DOPPLER MODULES AND VEHICLE DETECTORS

N CIRCULATORS AND ISOLATORS

P MISCELLANEOUS

 **INDEX**

Electronic components and materials for professional, industrial and consumer uses from the world-wide Philips Group of Companies

- Argentina:** PHILIPS ARGENTINA S.A., Div. Elcoma, Vedia 3892, 1430 BUENOS AIRES, Tel. 541-7141/7242/7343/7444/7545.
- Australia:** PHILIPS INDUSTRIES HOLDINGS LTD., Elcoma Division, 67 Mars Road, LANE COVE, 2066, N.S.W., Tel. 427 08 88.
- Austria:** ÖSTERREICHISCHE PHILIPS BAUELEMENTE Industrie G.m.b.H., Triester Str. 64, A-1101 WIEN, Tel. 62 91 11.
- Belgium:** N.V. PHILIPS & MBL ASSOCIATED, 9, rue du Pavillon, B-1030 BRUXELLES, Tel. (02) 242 74 00.
- Brazil:** IBRAPE, Caixa Postal 7383, Av. Brigadeiro Faria Lima, 1735 SAO PAULO, SP, Tel. (011) 211-2600.
- Canada:** PHILIPS ELECTRONICS LTD., Electron Devices Div., 601 Milner Ave., SCARBOROUGH, Ontario, M1B 1M8, Tel. 292-5161.
- Chile:** PHILIPS CHILENA S.A., Av. Santa Maria 0760, SANTIAGO, Tel. 39-4001.
- Colombia:** SADAPE S.A., P.O. Box 9805, Calle 13, No. 51 + 39, BOGOTA D.E. 1., Tel. 600 600.
- Denmark:** MINIWATT A/S, Emdrupvej 115A, DK-2400 KOBENHAVN NV., Tel. (01) 69 16 22.
- Finland:** OY PHILIPS AB, Elcoma Division, Kaivokatu 8, SF-00100 HELSINKI 10, Tel. 1 72 71.
- France:** R.T.C. LA RADIOTECHNIQUE-COMPELEC, 130 Avenue Ledru Rollin, F-75540 PARIS 11, Tel. 355-44-99.
- Germany:** VALVO, UB Bauelemente der Philips G.m.b.H., Valvo Haus, Burchardstrasse 19, D-2 HAMBURG 1, Tel. (040) 3296-0.
- Greece:** PHILIPS S.A. HELLENIQUE, Elcoma Division, 52, Av. Syngrou, ATHENS, Tel. 92151111.
- Hong Kong:** PHILIPS HONG KONG LTD., Elcoma Div., 15/F Philips Ind. Bldg., 24-28 Kung Yip St., KWAI CHUNG, Tel. (0)-24 51 21.
- India:** PEICO ELECTRONICS & ELECTRICALS LTD., Elcoma Div., Ramon House, 169 Backbay Reclamation, BOMBAY 400020, Tel. 295144.
- Indonesia:** P.T. PHILIPS-RALIN ELECTRONICS, Elcoma Div., Panim Bank Building, 2nd Fl., Jl. Jend. Sudirman, P.O. Box-223, JAKARTA, Tel. 716 13
- Ireland:** PHILIPS ELECTRICAL (IRELAND) LTD., Newstead, Clonskeagh, DUBLIN 14, Tel. 69 33 55.
- Italy:** PHILIPS S.p.A., Sezione Elcoma, Piazza IV Novembre 3, I-20124 MILANO, Tel. 2-6994.
- Japan:** NIHON PHILIPS CORP., Shuwa Shinagawa Bldg., 26-33 Takanawa 3-chome, Minato-ku, TOKYO (108), Tel. 448-5611.
(IC Products) SIGNETICS JAPAN LTD., 8-7 Sanbancho Chiyoda-ku, TOKYO 102, Tel. (03)230-1521.
- Korea:** PHILIPS ELECTRONICS (KOREA) LTD., Elcoma Div., Philips House, 260-199 Itaewon-dong, Yongsan-ku, C.P.O. Box 3680, SEOUL, Tel. 794-4
- Malaysia:** PHILIPS MALAYSIA SDN. BERHAD, Lot 2, Jalan 222, Section 14, Petaling Jaya, P.O.B. 2163. KUALA LUMPUR, Selangor, Tel. 77 44 11.
- Mexico:** ELECTRONICA S.A. de C.V., Varsovia No. 36, MEXICO 6, D.F., Tel. 533-11-80.
- Netherlands:** PHILIPS NEDERLAND, Marktgroep Elconco, Postbus 90050, 5600 PB EINDHOVEN, Tel. (040) 79 33 33.
- New Zealand:** PHILIPS ELECTRICAL IND. LTD., Elcoma Division, 2 Wagener Place, St. Lukes, AUCKLAND, Tel. 894-160.
- Norway:** NORSK A/S PHILIPS, Electronica Dept., Sandstuveien 70, ÖSLO 6, Tel. 68 02 00.
- Peru:** CADESA, Av. Alfonso Ugarte 1268, LIMA 5, Tel. 326070.
- Philippines:** PHILIPS INDUSTRIAL DEV. INC., 2246 Pasong Tamo, P.O. Box 911, Makati Comm. Centre, MAKATI-RIZAL 3116, Tel. 86-89-51 to 59.
- Portugal:** PHILIPS PORTUGESA S.A.R.L., Av. Eng. Duarte Pacheco 6, LISBOA 1, Tel. 68 31 21.
- Singapore:** PHILIPS PROJECT DEV. (Singapore) PTE LTD., Elcoma Div., Lorong 1, Toa Payoh, SINGAPORE 1231, Tel. 25 38 811.
- South Africa:** EDAC (Pty.) Ltd., 3rd Floor Rainer House, Upper Railway Rd. & Ove St., New Doornfontein, JOHANNESBURG 2001, Tel. 614 2362/7.
- Spain:** MINIWATT S.A., Balmes 22, BARCELONA 7, Tel. 301 63 12.
- Sweden:** PHILIPS COMPONENTER A.B., Lidingsvägen 50, S-11584 STOCKHOLM 27, Tel. 08/67 97 80.
- Switzerland:** PHILIPS A.G., Elcoma Dept., Ailmendstrasse 140-142, CH-8027 ZÜRICH, Tel. 01-488 22 11.
- Taiwan:** PHILIPS TAIWAN LTD., 3rd Fl., San Min Building, 57-1, Chung Shan N. Rd, Section 2, P.O. Box 22978, TAIPEI, Tel. (02)-5631717.
- Thailand:** PHILIPS ELECTRICAL CO. OF THAILAND LTD., 283 Silom Road, P.O. Box 961, BANGKOK, Tel. 233-6330-9.
- Turkey:** TURK PHILIPS TICARET A.S., EMET Department, Inonu Cad. No. 78-80, ISTANBUL, Tel. 43 59 10.
- United Kingdom:** MULLARD LTD., Mullard House, Torrington Place, LONDON WC1E 7HD, Tel. 01-580 6633
- United States:** (Active Devices & Materials) AMPEREX SALES CORP., Providence Pike, SLATERSVILLE, R.I. 02876, Tel. (401) 762-9000.
(Passive Devices) MEPCO/ELECTRA INC., Columbia Rd., MORRISTOWN, N.J. 07960, Tel. (201)539-2000.
(Passive Devices & Electromechanical Devices) CENTRALAB INC., 5855 N. Glen Park Rd., MILWAUKEE, WI 53201, Tel. (414)228-7380.
(IC Products) SIGNETICS CORPORATION, 811 East Arques Avenue, SUNNYVALE, California 94086, Tel. (408) 739-7700.
- Uruguay:** LUZIELECTRON S.A., Avda Uruguay 1287, P.O. Box 907, MONTEVIDEO, Tel. 914321.
- Venezuela:** IND. VENEZOLANAS PHILIPS S.A., Elcoma Dept., A. Ppal de los Ruices, Edif. Centro Colgate, CARACAS, Tel. 36 05 11.
- For all other countries apply to:** Philips Electronic Components and Materials Division, Corporate Relations & Projects, Building BA63, 5600 MD EINDHOVEN, THE NETHERLANDS, Tel. (040) 72 33 04, Telex 35000.

A29

© 1982 N.V. Philips' Gloeilampenfabrieken

This information is furnished for guidance, and with no guarantees as to its accuracy or completeness; its publication conveys no licence under any patent or other right, nor does the publisher assume liability for any consequence of its use; specifications and availability of goods mentioned in it are subject to change without notice; it is not to be reproduced in any way, in whole or in part, without the written consent of the publisher.